

The logo for "Thinking Space" consists of a series of black and grey squares arranged in a grid that is slightly offset and tilted, creating a sense of depth and movement.

THINKING SPACE

**PVS®**

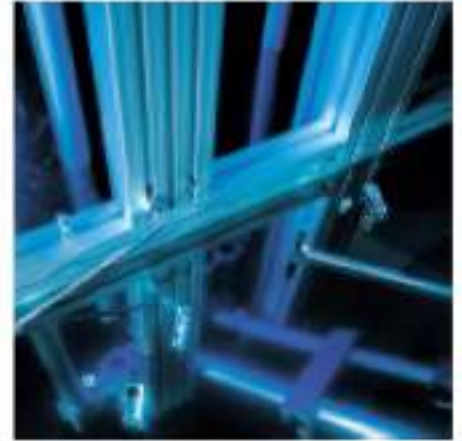

**The extrusion  
connection  
system that  
delivers  
custom-made  
structural  
solutions.**

## The KANYA extrusion-connecting-system PVS®: The modular assembly system with infinite possibilities.

*Since its founding in 1974, KANYA and our partners live by the principle that we are not satisfied until you are. To achieve this goal, we know we need to meet your demands for schedule and value. For the environment's sake, we maintain sustainable business ethics.*

*With the product variety of the KANYA-system you can realize economic problem solutions. Or let us put our many years of experience to work and develop a solution for you. Profit also from the innovative ability of the KANYA team. Our newest invention, which is patented, is the connecting system PVS® EASY, which you'll find on page 98–100 of this catalog.*

*With our international distribution network, you can be confident your Kanya solution will be supported globally.*

*Your KANYA-Team*



**Services  
Technical data**



**Editorial  
Services**

Pages 1–23



**Material data  
Tolerances**

Pages 24–25

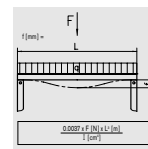

**Strength  
calculations**

Pages 26–27

**Extrusions**



**Extrusion base 50**

Pages 36–40



**Extrusion base 50**

Pages 41–43

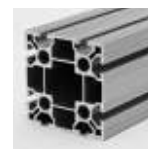

**Extrusion base 50**

Pages 44–45



**Extrusion base 40**

Pages 48–53

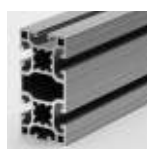

**Extrusion base 40**

Pages 54–55



**Extrusion base 40**

Pages 56–58

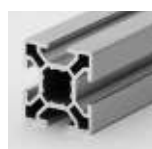

**Extrusion base 30**

Pages 62–67



**Extrusion base 30**

Pages 68–69



**Extrusion base 30**

Pages 70–71



**Extrusion base 20**

Pages 74–75



**Extrusion base 20**

Pages 75–77



**Special-  
extrusions**

Pages 78–85

**Connecting technique**



**PVS – the  
original**

Pages 90–91



**PVS-Connector**

Pages 92–96



**Fastening torque  
and  
Forces diagram**

Page 97

**Accessories**



**Mounting brackets,  
Clamping block,  
Uniblocks, Clamping  
blocks, Attachment  
brackets, T-bolts**

Pages 106–109



**Threaded plates,  
Extrusion nuts,  
spring nuts, Anti  
twist spigots,  
threaded inserts**

Pages 110–113



**Leveling feet,  
Base plates, Foot  
plates, Floor bol-  
ting bracket, Leg  
bolt-down socket**

Pages 114–118



**Enclosures panels,  
Sheets, expanded  
metal, Composite  
panels, Acrylic glass,  
Steel wire mesh**

Pages 132–135



**Hinges, Hing  
extrusions, Joints,  
Joint extrusions,  
Corner pieces**

Pages 136–139



**Handles, Ball  
catches, Magnetic  
fasteners and  
Quick-release  
fasteners**

Pages 140–143

**Special-tools  
Kanyathek**



**Drill jig,  
Drill bits**

Page 157



**Cutting die,  
combination tool**

Page 158



**Special allen key**

Page 159



**Summary of extrusions available**

Pages 29–33



**Machining information**

Pages 34–35

**Services  
Technical data**



**Extrusion base 50**

Pages 46–47

**Extrusion base 50**



**Extrusion base 40**

Page 59



**Extrusion base 40**

Pages 60–61

**Extrusion base 40**



**Extrusion base 30**

Pages 72–73

**Extrusion base 30**



**Bracket extrusions**

Pages 86–87



**Square pipe  
Hinge extrusions  
Handle extrusion**

Pages 88–89

**Extrusion base 20  
Special-extrusions**



**PVS-EASY**

Pages 98–99



**PVS-Light**

Pages 100–103

**PVS-Connecting  
technique**



**Castors, rollers,  
trolleys**

Pages 119–121



**Plastic-  
slide extrusions,  
sliding hook**

Pages 122–123



**Cable ducts,  
Installation-rings,  
end caps, Filler  
strips and sealing  
strips**

Pages 124–131

**Accessories**



**Locks,  
safety switches**

Pages 144–145



**Sealing plates  
O-ring and  
gaskets**

Pages 146–147



**Linear bearings,  
linear sliding  
block, sliding  
plates, rollers,  
roller shield**

Pages 148–155

**Special tools  
Dealers**



**Kanyathek**

Pages 160–161



**KANYA world wide**

Page 162

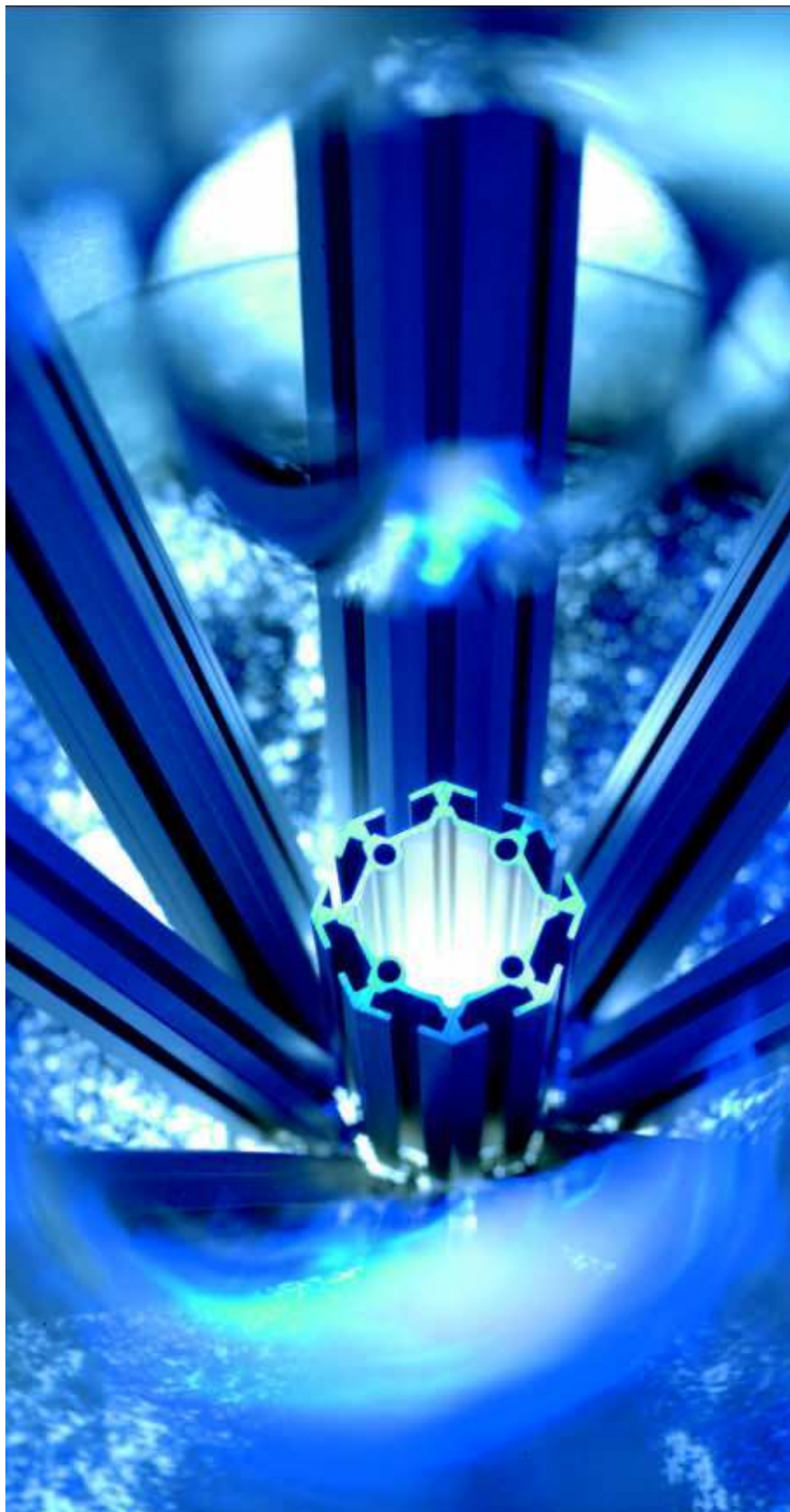

## You have the ideas and visions!

We help you to realize them with our know-how, our extrusion connection system and the large assortment.

Our strength lies in complete solutions – A large list of references proves it. Benefit from our many years of experience in construction.

Optimizing the potential for synergies, we can come up with the perfect solution to meet your needs. KANYA products can be found everywhere. Wherever we are needed, there is a well-trained and innovative team on hand to help you.

**A global  
KANYA service.**



Unwinding machine



Automatic palletizing plant



Longitudinal and transverse cutting machine



Newspaper handling system



Punch and packing automat



Fully automatic racking installation



Cleaning plant



Plane wing testing machine



Filling construction



Cotton pad machine



Packing construction



Filling construction



Transforming construction

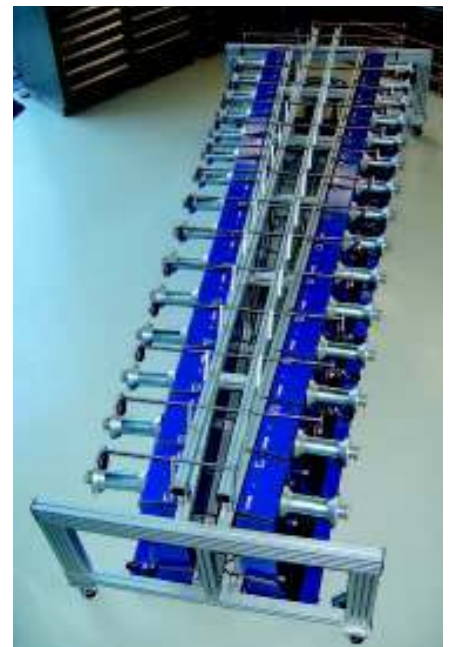

Unwinding machine



## You expect more!

**We adapt professionally on our special machines profiles, accessories and special parts.**

With our experienced engineering team, expect efficient designs.

With our skilled machinists, expect precision cuts with minimal waste.

With our knowledgeable staff, expect short turnaround times.

**A valuable KANYA service.**



Clamping and measuring device



Feeder and transfer system



Punch automat with acoustic enclosure



Vacuum testing facility



Test plant for carbonate bicycle frames



Automatic placement machine



Automatic gilding plant



Workstation with chapel



Installation workstation



Manual work station



Mobile work desk

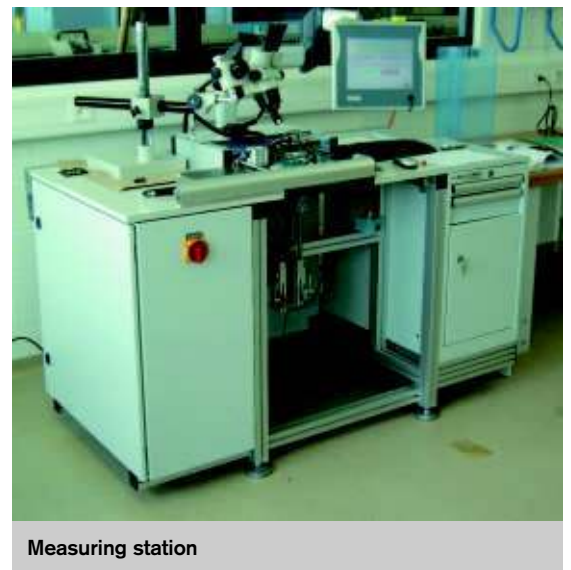

Measuring station



## You have time and customer pressure!

**We offer you top quality with short delivery times.**

What ever extrusion or accessory part you ever require – we are ready to deliver.

According to your demands, we deliver individual parts and extrusions, finished material or complete mounted solutions. Final assembly at your locale is also a part of our service. In any case your custom-made solution will be ready in a short time.

**A scheduled KANYA service.**



Casing for deburring facility with safety glass



Darkroom

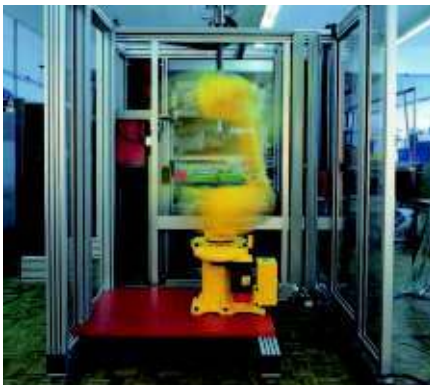

Robot cell



Safety housing



Safety device with automatic door



Safety housing



Dividing wall to manufacturing-plant



Dust protection cabin



Machine case



Safety-tent space technology



Acoustic protection for blower



Motorbike wash cubicle



Acoustic protection cabin

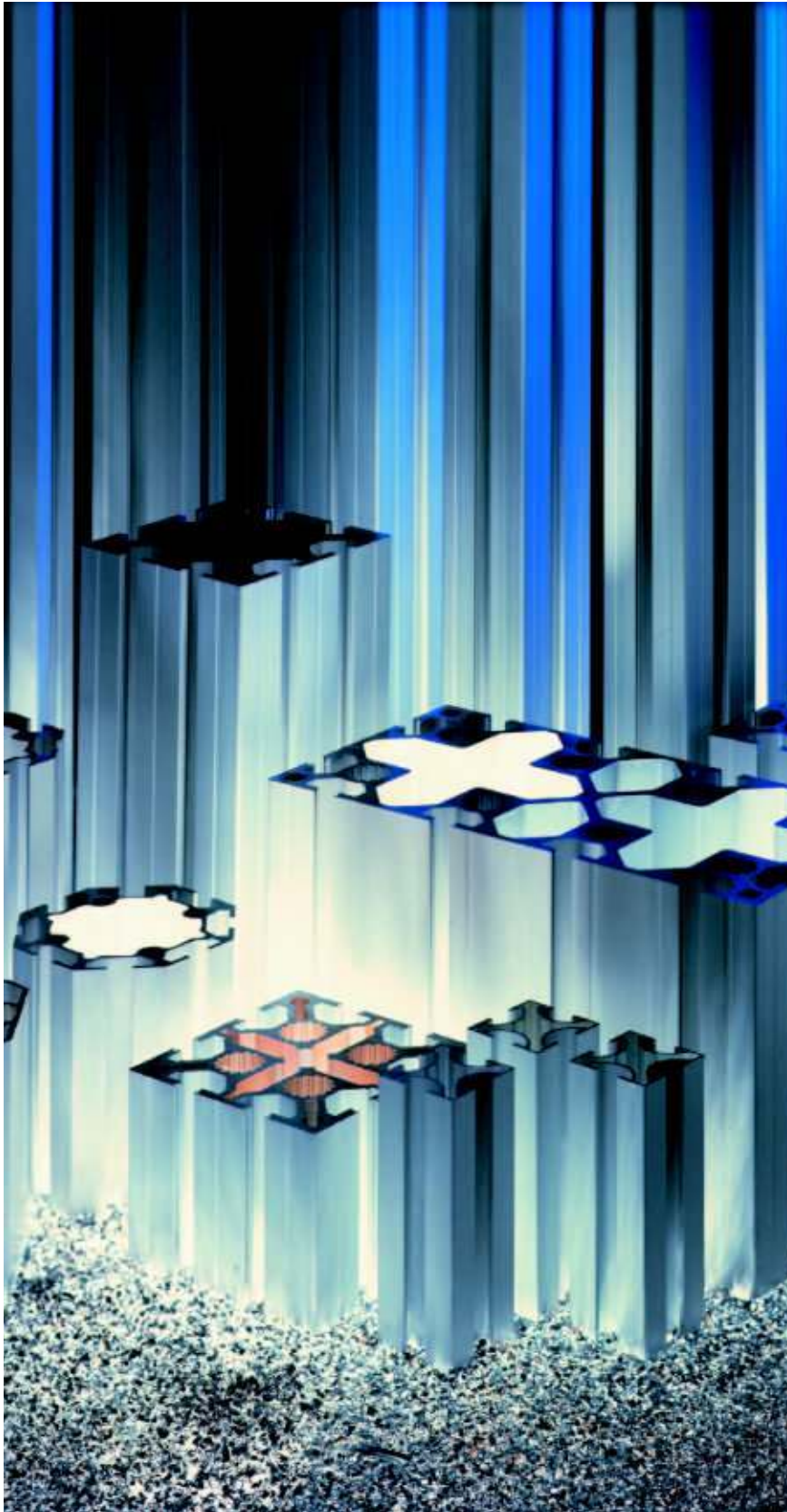

## You have projects and need designs!

**We offer you the necessary know-how and the matching applications.**

Whatever tasks you give us, you can be sure of our technical support. Our engineers and technicians will be happy to advise you by phone or send you information by post, e-mail or fax or visit you with samples for a technical discussion.

Your specifications become concrete solutions. We'll work with you to develop a complete parts list for your proposals and designs.

The diversity of usage for our products is unlimited.

**A standard KANYA service.**

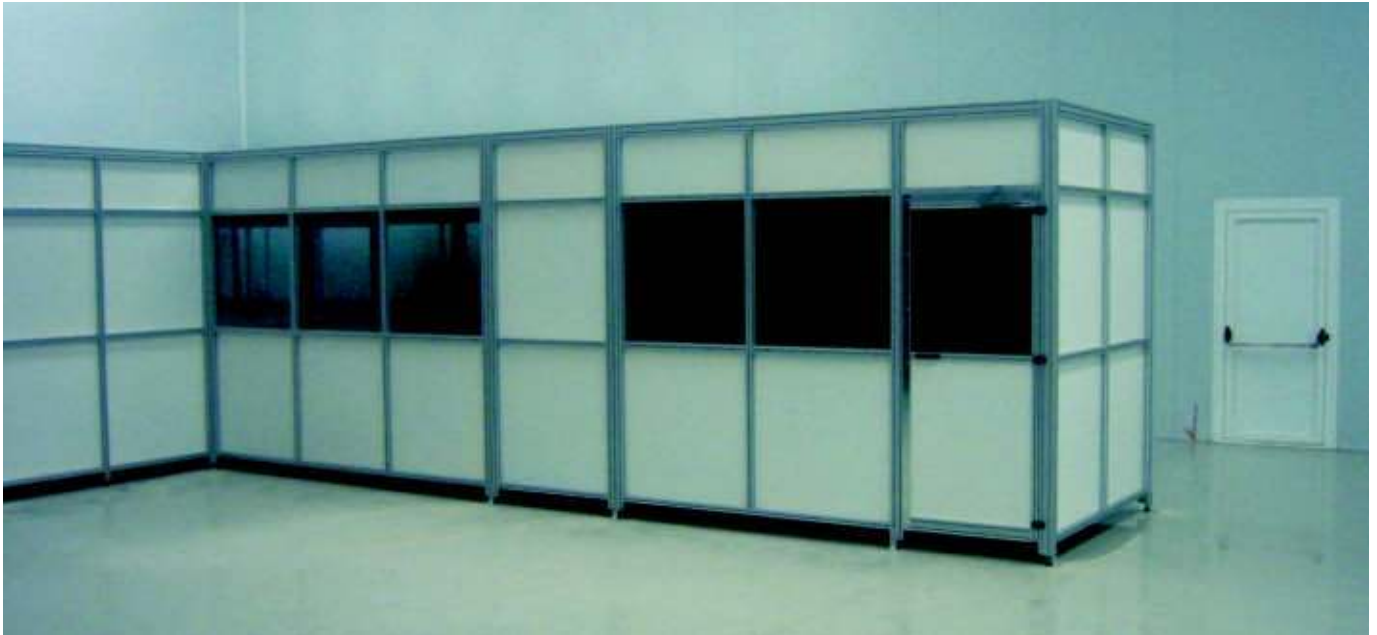

Workshop office



Clean room housing



Acoustic protection cabin



Clean room testing cell



Batch device sterilization



Breadboard construction (laboratory equipment)



Oxide trolley for patients



Scale rack with heat lamp for infants



Protection cover for lab device



Laboratory equipment with ceiling grid system



Platform for astronomical observatory



Laser research plant



Research model jet fighter



Solar power station

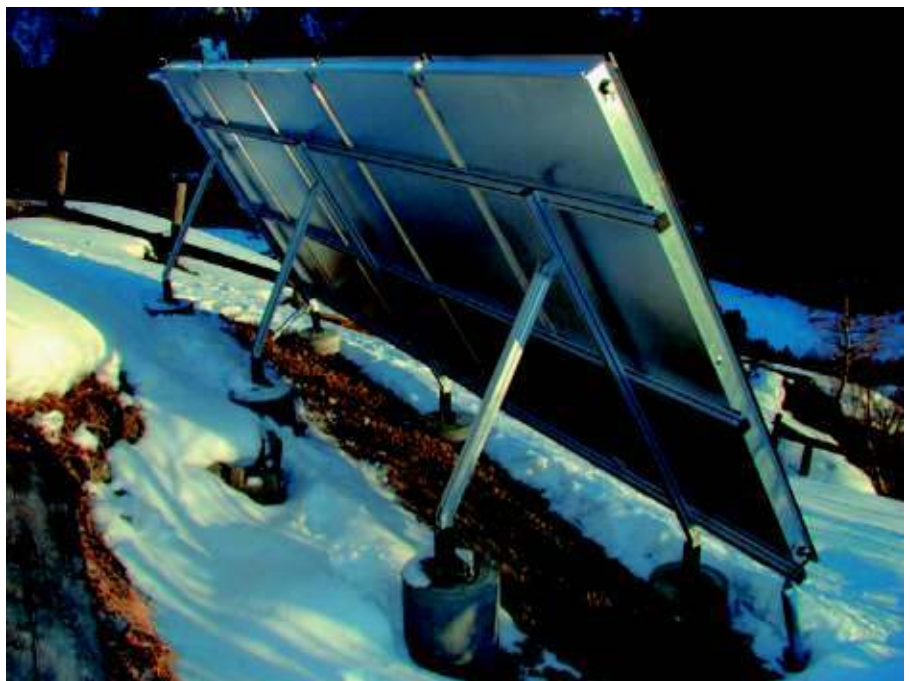

Solar plant



## You have special requests!

**We can fulfill them, because we have done so many different projects.**

From production facilities to interior furnishing to a hobby, with the Kanya system your possibilities are unlimited.

You can start with a keyword!! From there we can trace a similar project in our database. If not, we can quickly and efficiently develop an attractive construction.

**A wonderful  
KANYA service.**



Mobile Easel



Mobile scale



Long-item storage rack



Tool wall



Dehydration vehicle



Rivet station



Jewelry equipment



Conference table



Sales counter



TV substructure



Multimedia workroom



Trailer for gardening



Soap box chassis



Model railway substructure



Patio roofage

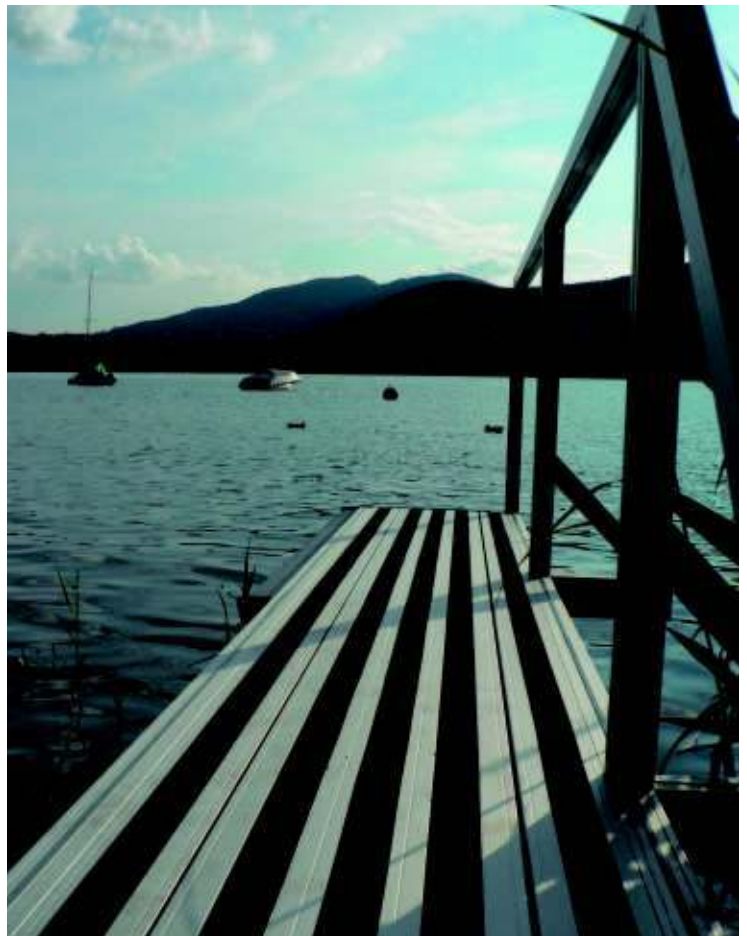

Boat stage

## Material data of Aluminium extrusions

Alloy	6063	
Quality	T66	Temper-hardened (F25)
DIN designation	3.3206.72	
Tolerances	DIN EN 12020	
Density/weight	$\delta$ : 2.7 g/cm <sup>3</sup>	
Tensile strength	R <sub>m</sub> : min 245 N/mm <sup>2</sup>	
Yield	R <sub>p</sub> 0.2: min 200 N/mm <sup>2</sup>	
Elongation	A <sub>5</sub> : min 10%	
	A <sub>10</sub> : min 8%	
Module of elasticity	E: 70 KN/mm <sup>2</sup>	
Brinell hardness	HB ~75	
Surface	Natural matt anodized. Depth approx. 12 $\mu$	Color anodized or powder coated in accordance with the RAL table, on request
Thermal expansion	0.0232 mm/m/° $\Delta$ t	



## Extrusion tolerances, extract from EN 12020-02

### 1. Straightness tolerances

Cavity extrusions may not exceed the values stated in the table for straightness tolerances  $h_1$ . The deviation  $h_2$  may not exceed a maximum of 0.3 mm over any length of  $l_2=300$ mm.

Length $l_1$ in m	up 1 m	up 2 m	up 3 m	up 4 m	up 5 m	up 6 m
Tolerance $h_1$ in mm	0.7	1.3	1.8	2.2	2.6	3.0

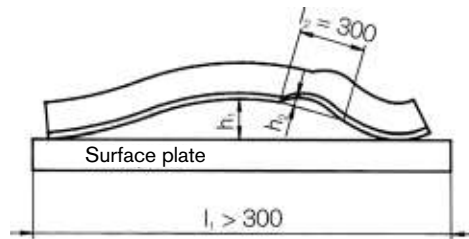

### 2. Twist tolerance v

The length-dependent twist tolerance  $v$  for cavity extrusions is shown in the table.

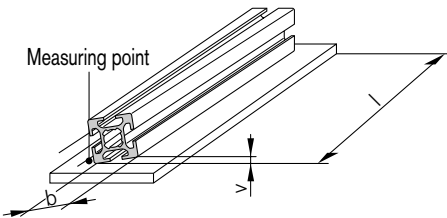

Width b in mm	Flatness tolerance v in mm for lengths in mm					
	- 1000	> 1000-2000	- 2000-3000	> 3000-4000	> 4000-5000	> 5000-6000
- 25	1.0	1.5	1.5	2.0	2.0	2.0
> 25 - 50	1.0	1.2	1.5	1.8	2.0	2.0
> 50 - 75	1.0	1.2	1.2	1.5	2.0	2.0
> 75 - 100	1.0	1.2	1.5	2.0	2.2	2.5
> 100 - 125	1.0	1.5	1.8	2.2	2.5	3.0
> 125 - 150	1.2	1.5	1.8	2.2	2.5	3.0
> 150 - 200	1.5	1.8	2.2	2.6	3.0	3.5
> 200 - 300	1.8	2.5	3.0	3.5	4.0	4.5

### 3. Inclination tolerance w

Where sides are of unequal length, inclination tolerance shall be relative to the angle of the shorter side.

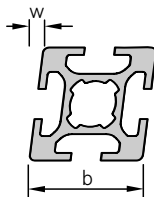

Width b in mm	Inclination tolerance w in mm	Width b in mm	Inclination tolerance w in mm
- 30	0.3	> 120 - 140	0.8
> 30 - 50	0.4	> 140 - 160	0.9
> 50 - 80	0.5	> 160 - 180	1.0
> 80 - 100	0.6	> 180 - 200	1.2
> 100 - 120	0.7	> 200 - 240	1.5

### 4. External tolerances

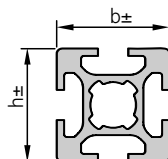

Width b, h in mm	Deviation in mm	Width b, h in mm	Deviation in mm
> 15 - 30	± 0.25	> 120 - 150	± 0.80
> 30 - 45	± 0.30	> 150 - 180	± 1.00
> 45 - 60	± 0.40	> 180 - 240	± 1.20
> 60 - 90	± 0.45	> 240 - 300	± 1.50
> 90 - 120	± 0.60		

## Strength calculations

Load case 1

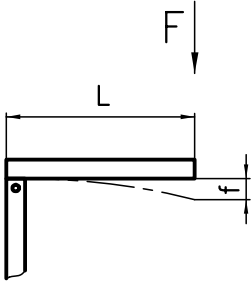

$$f [\text{mm}] = \frac{0.476 \times F [\text{N}] \times L^3 [\text{m}]}{I [\text{cm}^4]}$$

**where**

- F = load in N
- L = extrusion length in m
- I = moment of inertia in cm<sup>4</sup>
- f = deflection in mm
- a/b = distance to the load point in m
- q = line load in N/m



**Example:**

A counterweight with a max. load of 500 N is to be fastened to an extruded arm 800 mm long. What will be the deflection of a 40x40 mm C01-1 type base extrusion?

$$\text{Deflection } f = \frac{0.476 \times 500 \times 0.8^3}{11.70} = 10.42 \text{ mm}$$

**Checking the bending stress:**

$$\delta = \frac{M_b}{W \times 10^3}$$

- δ = bending stress in N/mm<sup>2</sup>
- M<sub>b</sub> = max. bending moment in Nmm
- W = section modulus in cm<sup>3</sup>

Load case 2

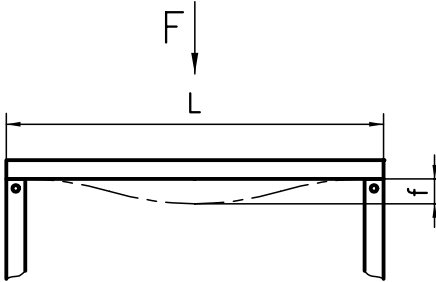

$$f [\text{mm}] = \frac{0.0074 \times F [\text{N}] \times L^3 [\text{m}]}{I [\text{cm}^4]}$$



**Example:**

An 1800 N load is placed in the middle of a beam. The unsupported length is 1200 mm. The max. permissible deflection is 1.0 mm. What sort of extrusion should be used for the beam?

$$\text{Deflection } f = \frac{0.0074 \times F \times L^3}{I} \Rightarrow I = \frac{0.0074 \times F \times L^3}{f}$$

$$\text{Moment of inertia } I = \frac{0.0074 \times 1800 \times 1.2^3}{1.0} = 23.02 \text{ cm}^4$$

⇒ Use a heavy duty extrusion MA1-1 where I = 29.37 cm<sup>4</sup>

Load case 3

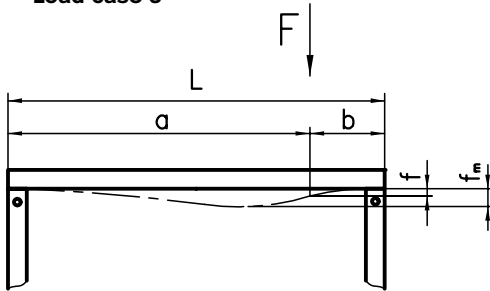

$$f [\text{mm}] = \frac{0.476 \times F [\text{N}] \times a^3 [\text{m}] \times b^3 [\text{m}]}{I [\text{cm}^4] \times L^3 [\text{m}]}$$

a > b

$$f_m [\text{mm}] = \frac{0.952 \times F [\text{N}] \times a^3 [\text{m}] \times b^2 [\text{m}]}{I [\text{cm}^4] \times L^2 [\text{m}]} \left( \frac{L [\text{m}]}{L [\text{m}] + 2a [\text{m}]} \right)^2$$

a < b

$$f_m [\text{mm}] = \frac{0.952 \times F [\text{N}] \times a^2 [\text{m}] \times b^3 [\text{m}]}{I [\text{cm}^4] \times L^2 [\text{m}]} \left( \frac{L [\text{m}]}{L [\text{m}] + 2b [\text{m}]} \right)^2$$

Example:

A cross-beam measuring 2500 mm in width has to support another beam 850 mm from the end of the cross-beam. The support load is 1200 N. A 50 x 100 base extrusion is used as the cross-beam. How great is the deflection at the point where the beam is placed?

$$\text{Deflection } f = \frac{0.476 \times 1200 \times 1.65^3 \times 0.85^3}{149.84 \times 2.5^3} = 0.67 \text{ mm}$$

where

- F = load in N
- L = extrusion length in m
- I = moment of inertia in cm<sup>4</sup>
- f = deflection in mm
- a/b = distance to the load point in m
- q = line load in N/m

Load case 4

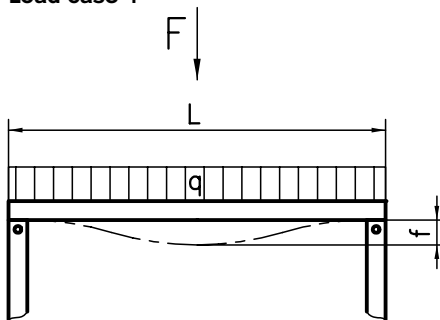

$$f [\text{mm}] = \frac{0.0037 \times F [\text{N}] \times L^3 [\text{m}]}{I [\text{cm}^4]}$$

$$F = q \times L$$

Example:

A measuring plate (whose intrinsic stability is ignored) may not bend by more than 0.4 mm. The measuring table is 1500 mm deep and the line load on each side of the table is 8000 N/m.

Which extrusion must be used to support the measurement plate?









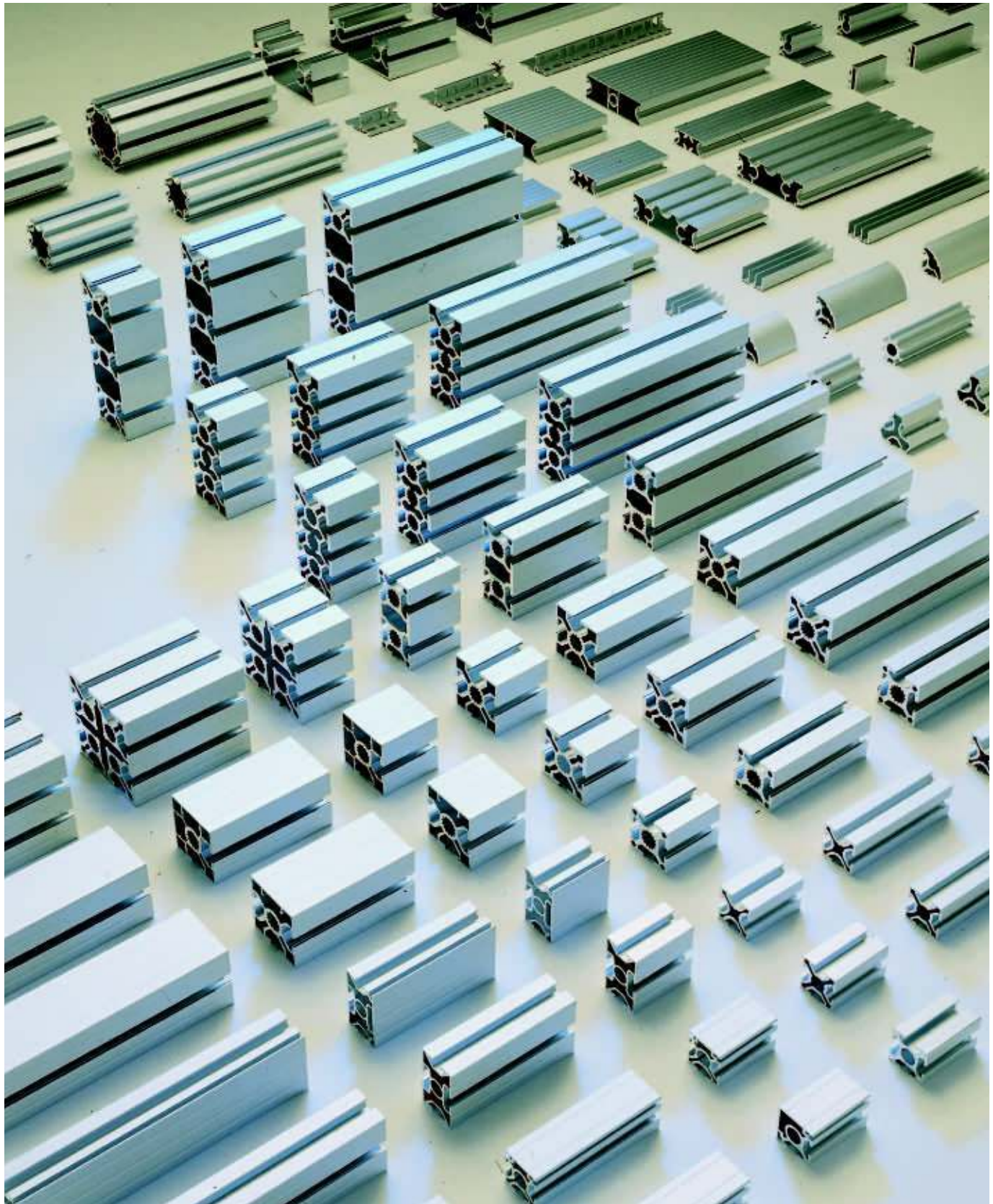





$$F = q \times L = 8000 \times 1,5 = 12000 \text{ N}$$

$$\text{Deflection } f = \frac{0.0037 \times F \times L^3}{I} \Rightarrow I = \frac{0.0037 \times F \times L^3}{f}$$







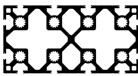







$$\text{Moment of inertia } I = \frac{0.0037 \times 12000 \times 1.5^3}{0.4} = 374.64 \text{ cm}^4$$









⇒ Use a heavy duty extrusion MA1-5 (100 x 100) where I = 380.00 cm<sup>4</sup>



Extrusion	type		Weight [kg/m]	lx,y [cm <sup>2</sup> ]	Wx,y [cm <sup>2</sup> ]	Page
Light weight extrusion 50x50	type AE2-1		1.8	16.01, 16.10	6.36, 6.44	36
Base extrusion 50x50	type A01-1		2.3	20.88	8.35	37
Heavy duty extrusion 50x50	type MA1-1		3.1	29.37	11.75	37
Face extrusion 50x50	type A01-8		2.2	20.38, 19.61	8.15, 7.55	38
Corner extrusion 50x50	type A01-7		2.2	16.90	6.76	38
Double face extrusion 50x50	type A02-4		2.0	19.59, 18.17	7.83, 7.27	39
Angle extrusion 50x45°	type A02-8		1.7	13.10	4.50	39
Face casing extrusion 50x50	type A03-8		2.2	20.40, 19.72	8.07, 7.89	40
Base extrusion 50x100	type A01-2		4.6	149.84, 41.25	29.97, 16.50	41
Heavy duty extrusion 50x100	type MA1-2		5.3	198.66, 50.28	39.73, 20.11	42
Face extrusion 50x100	type MA1-4		5.2	203.67, 54.31	40.73, 21.03	43
Base extrusion 100x100	type MA2-5		8.1	324.73	64.95	44
Heavy duty extrusion 100x100	type MA1-5		9.5	380.00, 365.00	76.00, 73.00	45
Beam extrusion 50x150	type MA1-3		7.1	608.31, 73.56	81.11, 29.42	46
Heavy duty extrusion 100x200	type MA1-9		17.0	2442.53, 718.61	244.25, 143.72	47











## Extrusion base 40 mm

Extrusion	type		Weight [kg/m]	I <sub>x,y</sub> [cm <sup>4</sup> ]	W <sub>x,y</sub> [cm <sup>3</sup> ]	Page
Super lightweight extrusion 40x40	type C03-1		1.3	8.20	4.10	48
Lightweight extrusion 40x40	type C02-1		1.5	9.35	4.67	48
Base extrusion 40x40	type C01-1		2.0	11.70	5.75	49
Face extrusion 40x40	type C01-8		2.0	11.66, 11.67	5.78, 5.83	49
Corner extrusion 40x40	type C01-7		1.5	9.21	4.53	50
Double face extrusion 40x40	type C02-4		1.5	9.56, 9.21	4.78, 4.60	50
Face casing extrusion 40x40	type CE2-2		1.6	9.78, 8.77	4.59, 4.39	51
Corner casing extrusion 40x40	type CE1-3		1.6	9.07, 8.98	4.52, 4.48	51
Four face extrusion 40x40	type CE1-0		1.6	9.41, 9.30	4.71, 4.66	52
Angle extrusion 45°	type CE4-4		1.4	9.08, 8.33	3.43, 2.98	52
Angle extrusion 40x45°	type C02-8		1.2	6.30	2.70	53
Softline extrusion 40x40	type C03-8		1.3	6.70	2.97	53
Lightweight extrusion 40x80	type C02-3		2.8	64.90, 17.70	16.23, 8.85	54
Base extrusion 40x80	type C01-3		3.7	81.95, 22.74	20.49, 11.37	54
Face extrusion 40x80	type C01-5		2.6	64.40, 17.20	16.10, 8.60	55

Extrusion	type		Weight [kg/m]	lx,y [cm <sup>2</sup> ]	Wx,y [cm <sup>2</sup> ]	Page
Light weight extrusion 40x120	type CE1-9		4.02	205.74, 25.74	34.29, 12.86	55
Beam extrusion 40x120	type C01-9		5.3	258.52, 33.43	43.09, 16.72	56
Beam extrusion 40x160	type C02-9		7.0	592.79, 44.36	74.09, 22.18	57
Angle extrusion 80x80x40	type C01-6		5.3	109.18	23.56	58
Base extrusion 80x80	type C01-4		6.0	154.70	38.68	59
Light weight extrusion 80x80	type C03-4		4.4	115.66	28.92	59
Beam extrusion 80x120	type MC1-2		8.40	451.20, 219.76	75.20, 54.94	60
Heavy duty extrusion 80x160	type MC1-9		11.0	1018.98, 296.53	112.37, 74.13	61

## Extrusion base 30 mm

Extrusion	type		Weight [kg/m]	I <sub>x,y</sub> [cm <sup>4</sup> ]	W <sub>x,y</sub> [cm <sup>3</sup> ]	Page
Super lightweight extrusion 30x30	type B03-1		0.7	2.63	1.76	62
Lightweight extrusion 30x30	type B02-1		0.9	2.95	1.97	62
Heavy duty extrusion 30x30	type MB1-1		1.1	3.82	2.54	62
Face extrusion 30x30	type B03-2		0.8	2.85, 2.83	1.90, 1.83	63
Face casing extrusion 30x30	type B02-2		0.9	2.93, 2.76	1.93, 1.84	63
Corner extrusion 30x30	type B02-3		0.8	2.70	1.75	64
Corner face extrusion 30x30	type B01-3		0.8	2.70	1.75	64
Two face extrusion 30x30	type B02-4		0.8	2.73, 2.74	1.82, 1.83	65
Softline extrusion 30x30	type B01-8		0.8	2.57	2.02	65
Angle extrusion 30°	type B04-3		0.9	3.23, 2.89	1.54, 1.48	66
Angle extrusion 45°	type B04-4		0.9	3.14, 2.91	1.44, 1.45	66
Angle extrusion 60°	type B04-6		0.9	3.14, 2.91	1.44, 1.45	67
Base extrusion 30x50	type B01-9		1.2	10.94, 4.33	4.38, 2.90	68
Face extrusion 30x50	type MB2-9		1.3	11.30, 4.55	4.52, 3.03	68
Face casing extrusion 30x50	type MB1-9		1.3	11.25, 4.84	4.50, 3.23	69
Face casing extrusion 30x60	type B03-6		1.5	19.33, 5.43	6.44, 3.60	69
Base extrusion 30x60	type B01-6		1.5	20.52, 5.20	6.84, 3.47	70
Base extrusion 60x60	type B02-6		2.4	35.83	11.94	70
Base 30 octagonal extrusion	type B15-3		2.8	51.01	14.09	71
Base extrusion 30x100	type MB1-2		2.3	80.77, 8.95	16.15, 5.97	72
Face casing extrusion 30x100	type B01-2		2.1	77.86, 8.79	15.57, 5.72	72
Face extrusion 30x300	type B03-3		5.10	1755.64, 26.06	117.04, 17.30	73

Extrusion	type		Weight [kg/m]	lx,y [cm <sup>2</sup> ]	Wx,y [cm <sup>2</sup> ]	Page
Base extrusion 20x20	type D01-5		0.38	0.60	0.60	74
Corner extrusion 20x20	type D01-3		0.42	0.65	0.65	74
Face extrusion 20x20	type D01-8		0.39	0.68, 0.59	0.68, 0.59	74
Softline extrusion 20x20	type D03-8		0.35	0.47	0.47	75
Base extrusion 20x40	type D01-7		0.73	3.91, 1.10	1.95, 1.10	75
Face extrusion 20x40	type D02-8		0.75	4.15, 1.26	2.07, 1.18	75
Base 20 mm octagonal extrusion	type D01-1		1.31	9.96	4.13	76
Box frame extrusion 20x40	type D01-6		0.7	2.60, 1.38	1.21, 1.38	76
Box frame extrusion 20x47	type D01-2		0.95	7.36, 1.84	3.13, 1.84	76
Box frame extrusion 20x95	type D01-4		1.26	44.26, 2.75	9.32, 2.75	77
Face extrusion 20x150	type D19-5		1.86	142.50, 4.41	18.85, 4.16	77

## Ordering overview Extrusion-machining codes

The order number is made up of the type of extrusion, with the machining code for each end and the length of the extrusion. The available codes for the machining are listed on the following chart. Manual and electronic codes are shown. The «manual» code covers the most standard machining. The «electronic» code is generated from the KanyaThek3D and defines the kind of machining and the position on the extrusions exactly.

Special machinings are indicated with the code -99 on the manual codes and with a # sign in the electronic code. In this case, a customer drawing is requested!

### The way to order with the codes:

- ① Choose the suitable extrusion
- ② Define the machining on the left side of the extrusion according to the following machining overview, if there is no machining the code is: Code -02 (-4000)
- ③ Define the machining on the right side of the extrusion according to the following machining overview, if there is no machining the code is: Code -02 (-4000)
- ④ Indicate the length of the used extrusion.

Special machining:

- ⑤ -99 (#)

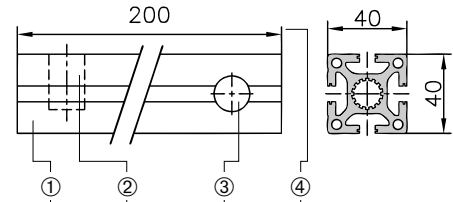

C01-1	-	11	-	13	/	200	manual
C01-1	-	A040	-	A001	/	200	electronic

Order number  
with standard machining

C01-1	-	11	-	13	-	99	/	200	manual
C01-1	-	A040	#	A001	/	200	electronic		

Order number  
with standard- and special machining

### MACHINING INFORMATION

#### 1. Cutting the extrusion to length without any other machining

cut to length tolerances after ISO 2768-m

#### 2a. Cutting the extrusion to length with threads in the main hole

1 thread M16/14/10x50			
1 thread M16/14/10x100			
1 thread M16/14/10/8x25			
1 Heli-Coil-insert M6x10*			
2 threads M16/14/8x50			
2 threads M16/14x100			
2 threads M16/14/8x25			
2 Heli-Coil-inserts M6x10*			
3 threads M16/14x50			
3 threads M16/14x100			
3 threads M16/14x25			
4 threads M16/14x50			
4 threads M16/14x100			
4 threads M16/14x25			
6 threads M16/14x50			
6 threads M16/14x100			
6 threads M16/14x25			
8 threads M16/14x50			
8 threads M16/14x100			
8 threads M16/14x25			

#### 2b. Cutting the extrusion to length and threads in the corners

4 threads M6x15	
4 threads M8x20	

#### 2c. Cutting extrusion to length and thread according to a drawing

n threads according drawing

\* extrusion 20x20/40 with heli-coil-inserts

### MACHINING CODES (MC)

manual	electronic		
-02	-4000		
-E1	-6000	-6002	-6080
-03	-7000	-7002	-7080
-E3	-5000	-5002	-5080
-H3	-8001		
-E2	-6003	-6005	-6009
-04	-7003	-7005	-7009
-E4	-5003	-5005	-5009
-H4	-8003	-8005	-8009
-G3	-6007	-6013	
-05	-7007	-7013	
-E5	-5007	-5013	
-G4	-600F	-601L	
-06	-700F	-701L	
-E6	-500F	-501L	
-G5	-603R		
-G6	-703R		
-E7	-503R		
-G7	-607Z		
-G8	-707Z		
-E8	-507Z		
-07	-57G0		
-08	-57G0		
-09	...#...		

**MACHINING INFORMATION**

**3. Cutting to length and PVS-drilling or easy-slot**

1 PVS-drilling		according to drawing
2 PVS-drillings		according to drawing
3 PVS-drillings		according to drawing
4 PVS-drillings		according to drawing
6 PVS-drillings		according to drawing
8 PVS-drillings		according to drawing

**4. Cutting extrusion in mitre cut**

For mitre cuts on non-symmetrical or additional machined extrusion ends, a customer drawing is essential.

mitre cut 45° (all extrusions)		
mitre cut		according to drawing

**5. Cutting extrusion in mitre cut with PVS-drilling**

Mitre cut 45° + PVS-drilling (extrusion 50x50/40x40/30x30/20x20)		
Mitre cut 45° + 2 PVS-drillings (extrusions 50x100/40x80/30x60/20x40)		
Mitre cut 45° + 4 PVS-drillings (extrusions 100x100/80x80/60x60)		
mitre cut + PVS-drilling		according to drawing

**6. Special machining**

machining according to drawing	according to drawing	
--------------------------------	----------------------	--

**MACHININGCODES (MC)**

manual		electronic	
Drilling	Slot	Drilling	Slot
-10	-10E	-A010	-A410
-11	-11E	-A040	-A440
-12	-12E	-A002	-A402
-13	-13E	-A001	-A401
-19	-19E	...#....	...#....
-20	-20E	-A0C0	-A4C0
-21	-21E	-A011	-A411
-29	-29E	...#....	...#....
-30	-30E	-A0W0	-A4W0
-39	-39E	...#....	...#....
-40	-40E	-A1W0	-A5W0
-40	-40E	-A0C6	-A4C6
-49	-49E	...#....	...#....
-60	-60E	-A0WE	-A4WE
-69	-69E	...#....	...#....
-80	-80E	-A1WY	-A5WY
-89	-89E	...#....	...#....
left	right	end 1	end 2
-50	-50	B000	C000
-51	-51	C000	B000
-59	-59	...#....	...#....
-70	-70	-B040	-C040
-71	-71	-C040	-B040
-72	-72	-B0C0	-C0C0
-73	-73	-C0C0	-B0C0
-74	-74	-B0C6	-C0C6
-75	-75	-C0C6	-B0C6
-79	-79	...#....	...#....
-99		...#....	

## 50x50 light extrusion type AE2-1

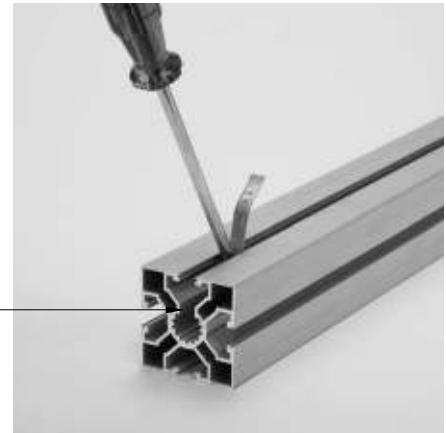
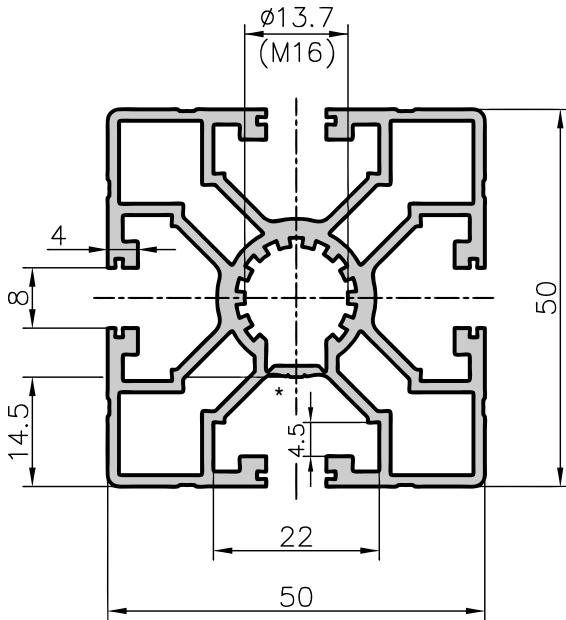

### Application

The light extrusion 50x50 offers many possibilities to the budget-minded engineer. Whether for machine guarding or machine chassis, in a light build version, using the «PVS-EASY» connecting technology this universal extrusion offers tremendous value.

### Extrusion with a rip off slot

All extrusions with the type .E.-. (AE2-1) has the rip off slots and are with the special cross section for use with the new PVS-EASY connecting technology (see page 99).

### Technical data

Ix	=	16.01 cm <sup>4</sup>
Iy	=	16.10 cm <sup>4</sup>
Wx	=	6.36 cm <sup>3</sup>
Wy	=	6.44 cm <sup>3</sup>
Cross section area	=	6.58 cm <sup>2</sup>
Weight	=	1.8 kg/m

### Order data

### Order number

50x50 light extrusion	
Standard length 5000mm	AE2-1-00/5000
50x50 light extrusion	
Cut to length	AE2-1-02-02/...
Extra machining	Pages 34/35

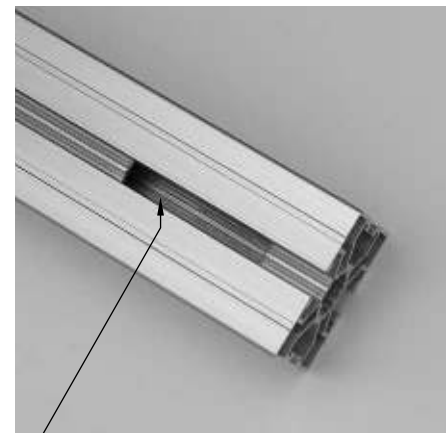

### 50x50 base extrusion type A01-1

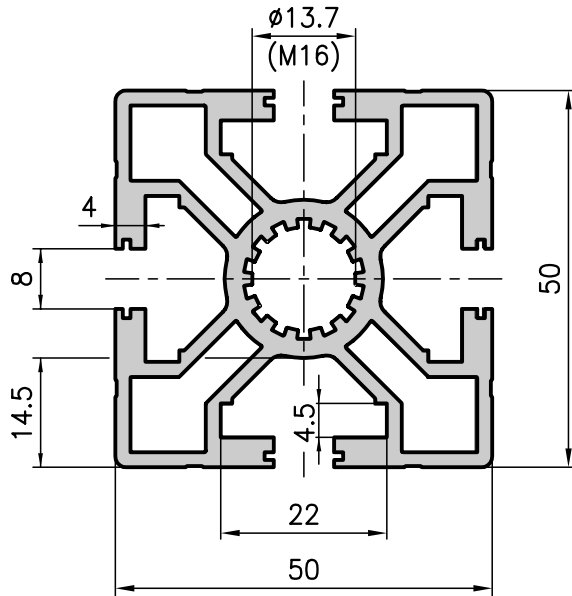

### 50x50 heavy duty extrusion type MA1-1

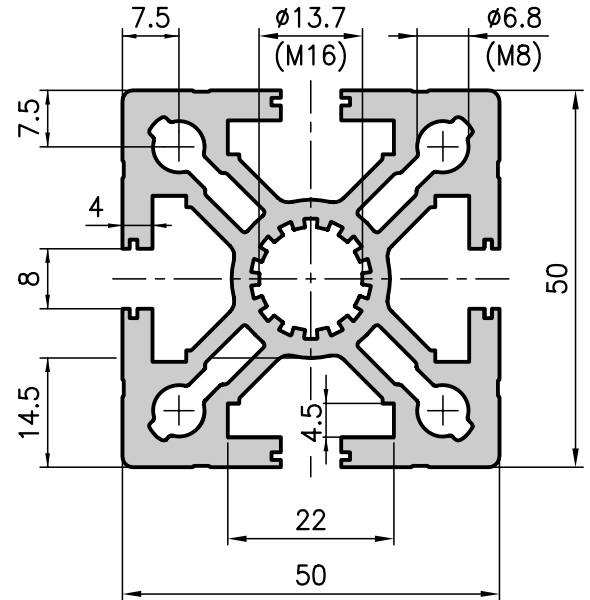

#### Application

These two extrusions are suitable for most design tasks thanks to their excellent weight and strength properties. Their useful features include holes for direct threading and small guide slots to cover the openings in the extrusions with aluminium strips, 0.8x10 type A39-10 or A39-17.

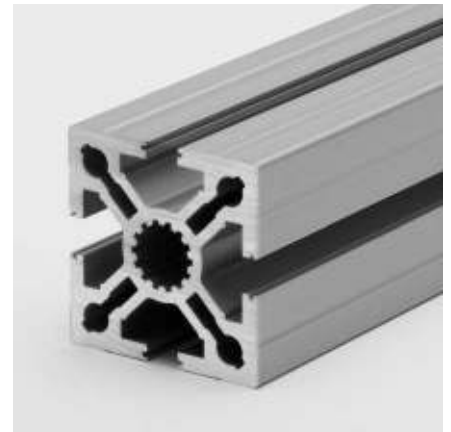

#### Technical data

$I_{x,y}$	=	20.88 cm <sup>4</sup>
$W_{x,y}$	=	8.35 cm <sup>3</sup>
Cross section area	=	8.55 cm <sup>2</sup>
Weight	=	2.3 kg/m

#### Order data      Order number

50x50 base extrusion	
Standard length 5000 mm	A01-1-00/5000
50x50 base extrusion	
Cut to length	A01-1-02-02/...
Extra machining	Pages 34/35

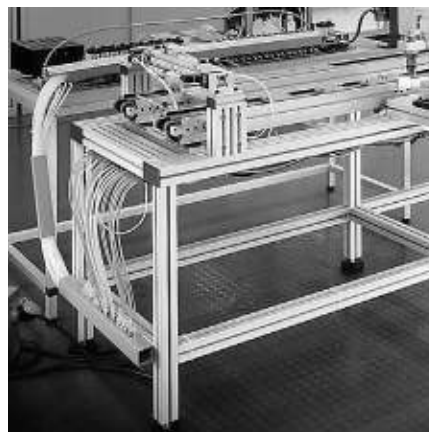

#### Technical data

$I_{x,y}$	=	29.37 cm <sup>4</sup>
$W_{x,y}$	=	11.75 cm <sup>3</sup>
Cross section area	=	11.26 cm <sup>2</sup>
Weight	=	3.1 kg/m

#### Order data      Order number

50x50 heavy duty extrusion	
Standard length 5000 mm	MA1-1-00/5000
50x50 heavy duty extrusion	
Cut to length	MA1-1-02-02/...
Extra machining	Pages 34/35

## 50x50 face extrusion type A01-8

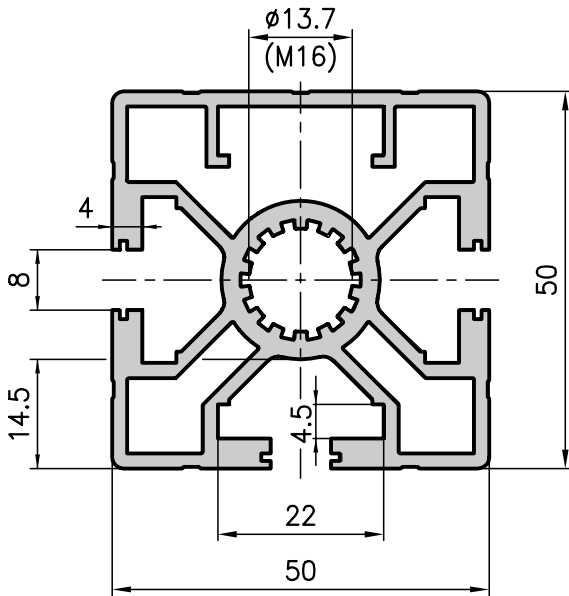

## 50x50 corner extrusion type A01-7

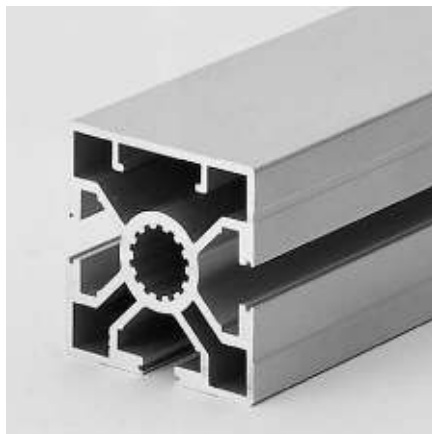
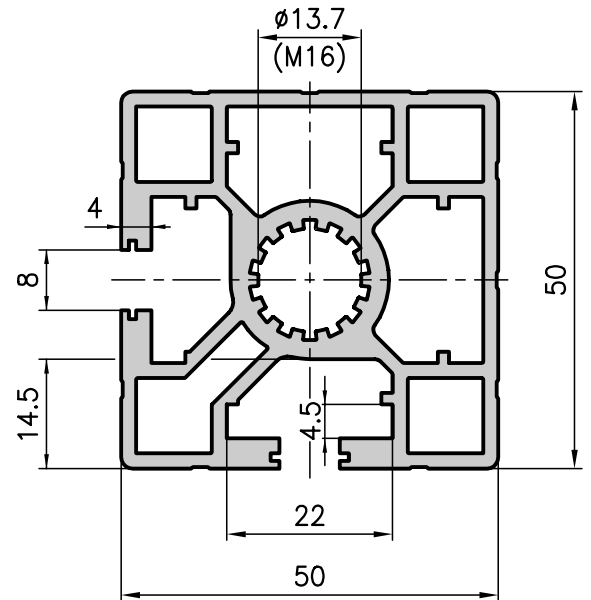

### Application

Corner and face extrusions are used in any applications where closed surfaces are required. The advantages of these are that they improve the appearance of the structures and also minimise the build up of dirt. Extrusions can be fitted onto the closed faces by drilling holes in the outer face of the extrusion at the required points and using A32-... type threaded plates. The small lugs inside the extrusion guide the plates.

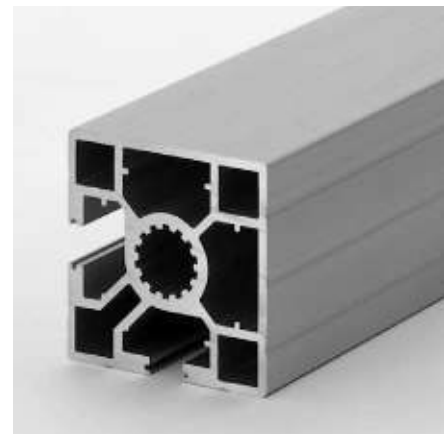

### Technical data

$I_x$	=	20.38 cm <sup>4</sup>
$I_y$	=	19.61 cm <sup>4</sup>
$W_x$	=	8.15 cm <sup>3</sup>
$W_y$	=	7.55 cm <sup>3</sup>
Cross section area	=	8.01 cm <sup>2</sup>
Weight	=	2.2 kg/m

### Order data

Order data	Order number
50x50 face extrusion	
Standard length 5000 mm	A01-8-00/5000
50x50 face extrusion	
Cut to length	A01-8-02-02/...
Extra machining	Pages 34/35

### Technical data

$I_{x,y}$	=	16.90 cm <sup>4</sup>
$W_{x,y}$	=	6.76 cm <sup>3</sup>
Cross section area	=	7.12 cm <sup>2</sup>
Weight	=	2.2 kg/m

### Order data

Order data	Order number
50x50 corner extrusion	
Standard length 5000 mm	A01-7-00/5000
50x50 corner extrusion	
Cut to length	A01-7-02-02/...
Extra machining	Pages 34/35



### 50x50 double face extrusion type A02-4

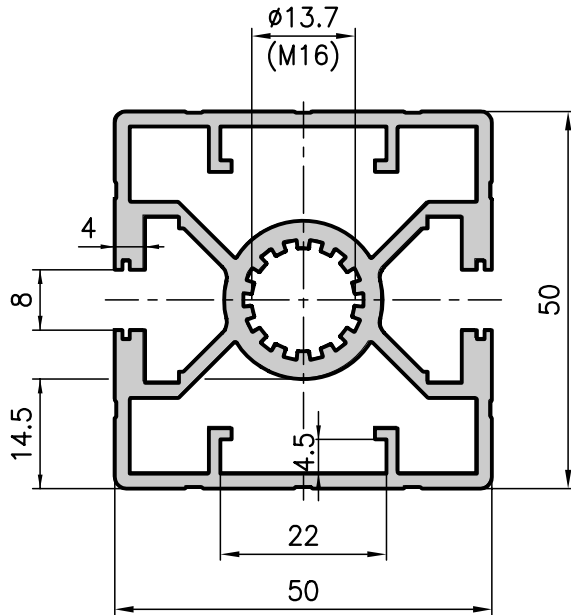

### 50x45° angle extrusion type A02-8

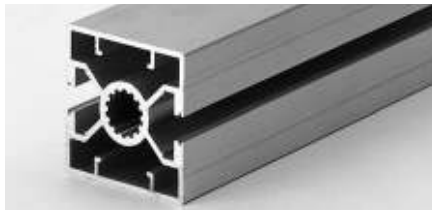
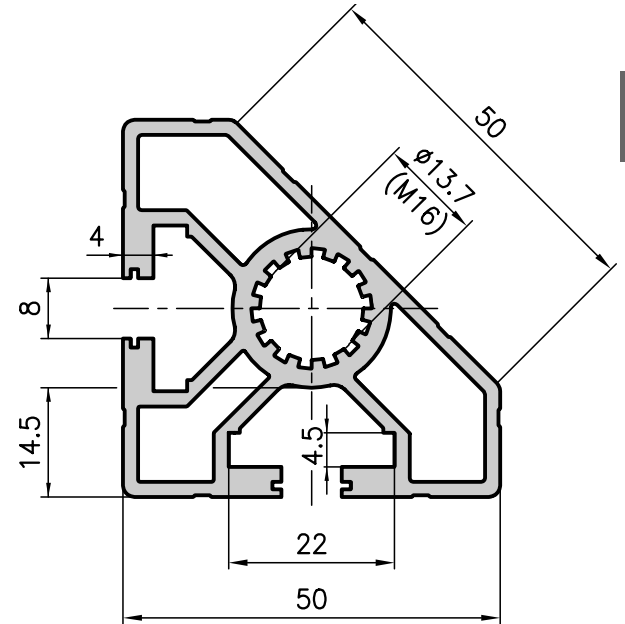

#### Application

For all types of enclosure, as well as for structures with extrusion faces which are mainly closed and for applications with an attractive design.



#### Technical data

$I_x$	=	19.59 cm <sup>4</sup>
$I_y$	=	18.17 cm <sup>4</sup>
$W_x$	=	7.83 cm <sup>3</sup>
$W_y$	=	7.27 cm <sup>3</sup>
Cross section area	=	7.39 cm <sup>2</sup>
Weight	=	2.0 kg/m

#### Order data

#### Order number

50x50 double face extrusion	
Standard length 5000 mm	A02-4-00/5000
50x50 double face extrusion	
Cut to length	A02-4-02-02/...
Extra machining	Pages 34/35

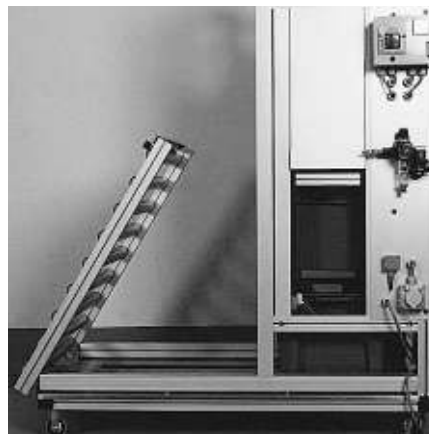

#### Technical data

$I_{x,y}$	=	13.10 cm <sup>4</sup>
$W_{x,y}$	=	4.50 cm <sup>3</sup>
Cross section area	=	6.40 cm <sup>2</sup>
Weight	=	1.7 kg/m

#### Order data

#### Order number

50x45° angle extrusion	
Standard length 5000 mm	A02-8-00/5000
50x45° angle extrusion	
Cut to length	A02-8-02-02/...
Extra machining	Pages 34/35

## 50x50 face extrusion with rip off panel slots type A03-8

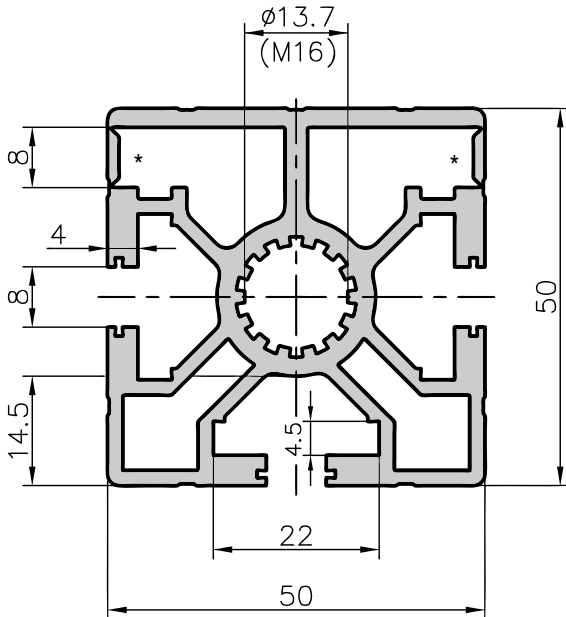

\* rip off slot

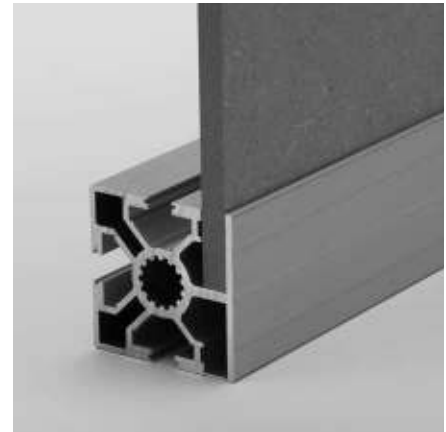

### Application

The one face closed extrusion gives the possibility to open a slot to insert a panel, ideal for delicate solar-panels. Rip off the slot, if necessary put in a sealing strip, insert panels and mount the frame. The 8 mm panels fit perfectly in the rip off slot.

### Technical data

$I_x$	=	20.40 cm <sup>4</sup>
$I_y$	=	19.72 cm <sup>4</sup>
$W_x$	=	8.07 cm <sup>3</sup>
$W_y$	=	7.89 cm <sup>3</sup>
Cross section area	=	8.28 cm <sup>2</sup>
Weight	=	2.2 kg/m

### Order data Order number

50x50 face extrusion with rip off slot	
Standard length 5000 mm	A03-8-00/5000
50x50 face extrusion with rip off slot	
Cut to length	A03-8-02-02/...
Extra machining	Pages 34/35



## 50x100 base extrusion type A01-2

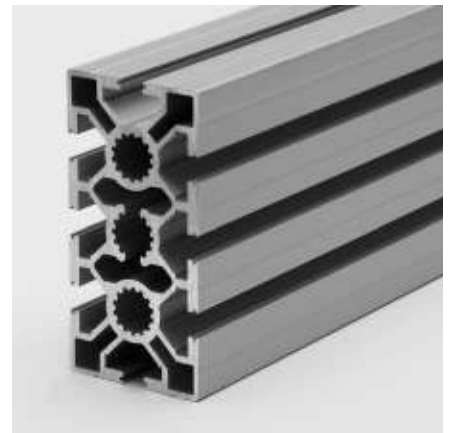
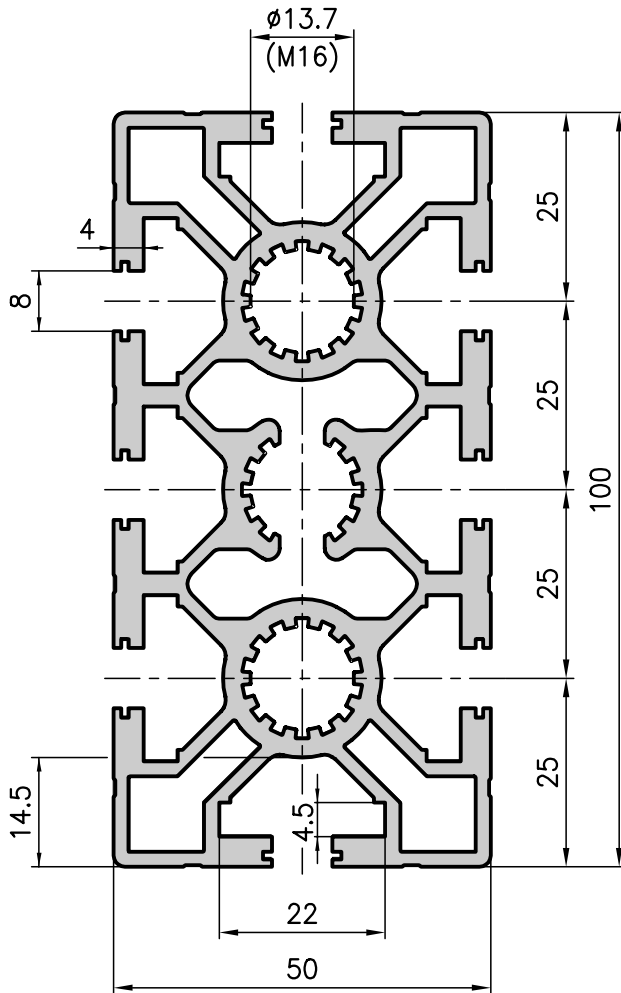

### Technical data

$I_x$	= 149.84 cm <sup>4</sup>
$I_y$	= 41.25 cm <sup>4</sup>
$W_x$	= 29.97 cm <sup>3</sup>
$W_y$	= 16.50 cm <sup>3</sup>
Cross section area	= 16.84 cm <sup>2</sup>
Weight	= 4.6 kg/m

### Order data

### Order number

50x100 base extrusion	
Standard length 5000 mm	A01-2-00/5000
Special length 6000 mm	A01-2-01/6000
50x100 base extrusion	
Cut to length	A01-2-02-02/...
Extra machining	Pages 34/35

### Application

This base extrusion is normally used for cross-beams. Further, its optimised cross section means that it is ideal for an extremely wide range of applications.

## 50x100 heavy duty extrusion type MA1-2

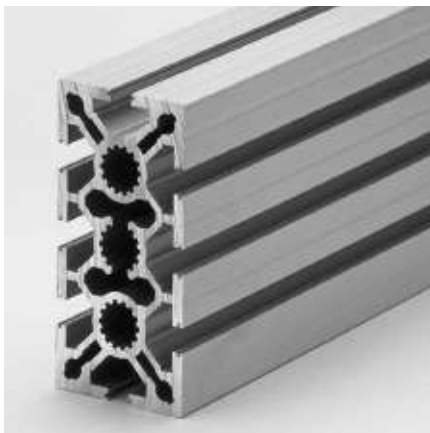
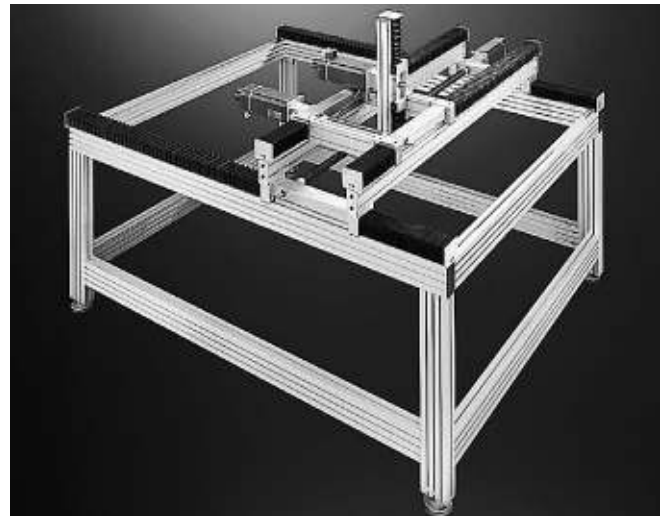
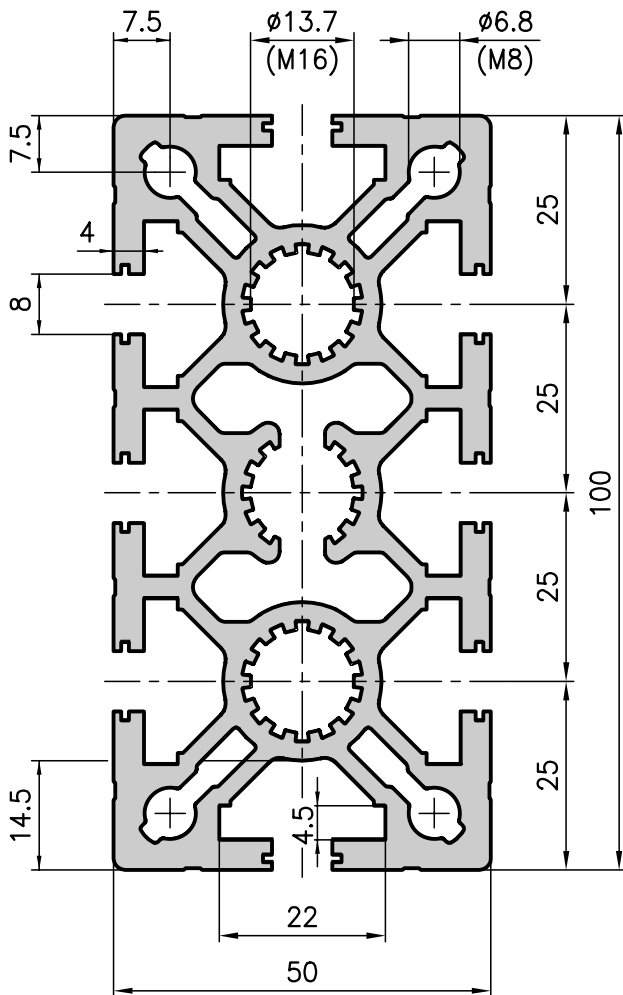

### Application

The heavy duty extrusion, like the A01-2 type base extrusion, is commonly used as a cross-beam. However, this design can also be used in many different applications combining excellent load-bearing capabilities and a lightweight structure!

### Technical data

$I_x$	= 198.66 cm <sup>4</sup>
$I_y$	= 50.28 cm <sup>4</sup>
$W_x$	= 39.73 cm <sup>3</sup>
$W_y$	= 20.11 cm <sup>3</sup>
Cross section area	= 19.79 cm <sup>2</sup>
Weight	= 5.3 kg/m

### Order data

### Order number

50x100 heavy duty extrusion	
Standard length 5000 mm	MA1-2-00/5000
Special length 6000 mm	MA1-2-01/6000

50x100 heavy duty extrusion	
Cut to length	MA1-2-02-02/...

Extra machining

Pages 34/35

## 50x100 face extrusion type MA1-4

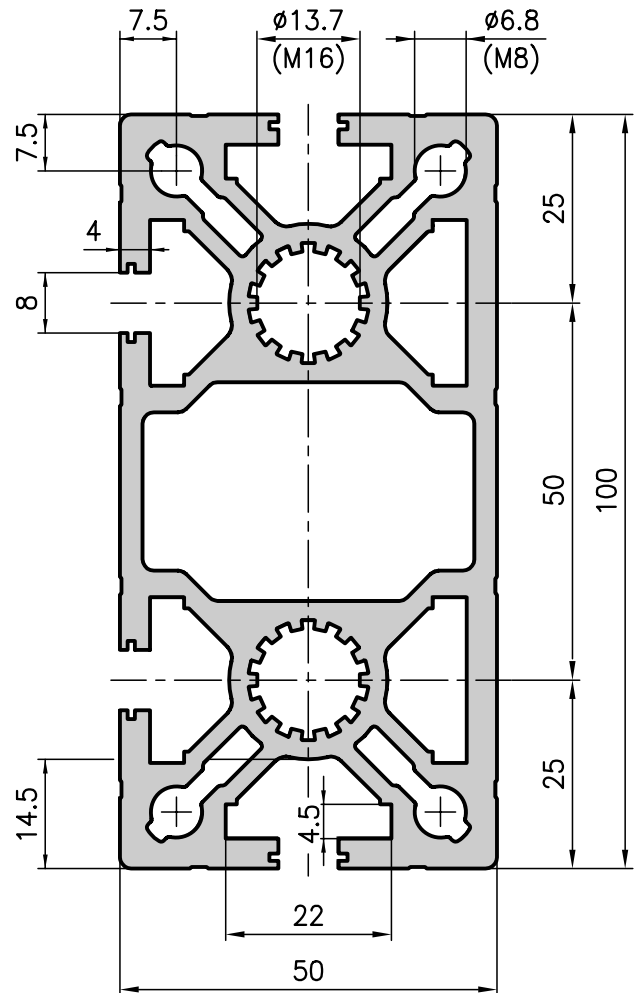

### Technical data

$I_x$	= 203.67 cm <sup>4</sup>
$I_y$	= 54.31 cm <sup>4</sup>
$W_x$	= 40.73 cm <sup>3</sup>
$W_y$	= 21.03 cm <sup>3</sup>
Cross section area	= 19.34 cm <sup>2</sup>
Weight	= 5.2 kg/m

### Order data

### Order number

50x100 face extrusion	
Standard length 5000 mm	MA1-4-00/5000
Special length 6000 mm	MA1-4-01/6000
50x100 face extrusion	
Cut to length	MA1-4-02-02/...
Extra machining	Pages 34/35

### Application

An extrusion which boasts all the advantages of the comparable A01-2 and MA1-2. In addition, its large inner cavity can be used to channel air, gas, water, oil, etc. The driving belt on a twin-belt conveyor can also be fed back in this chamber. The sealed face keeps dirt out. The extrusion can be extended using the closed threaded-plate slots. Simply drill a hole, place a threaded plate behind the hole and carry on building!

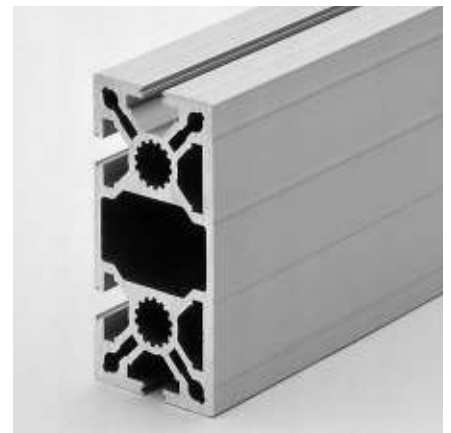

## 100x100 base extrusion type MA2-5

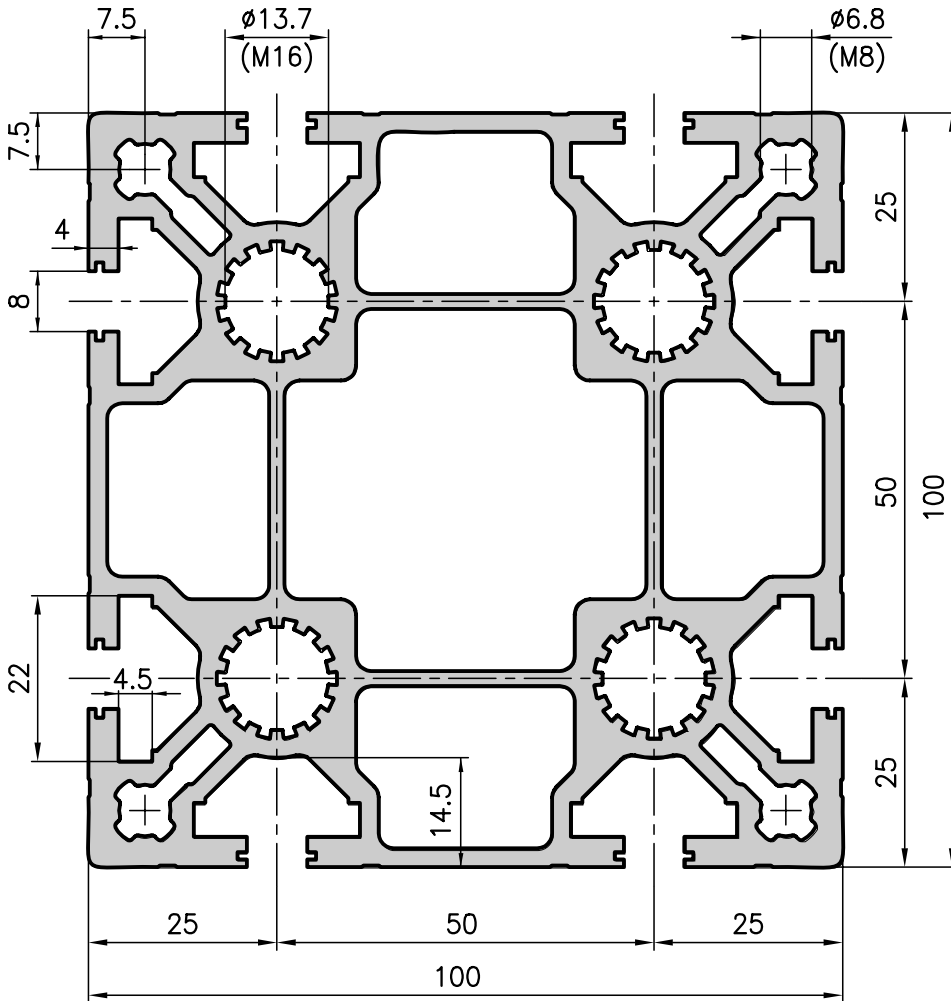

### Application

This versatile extrusion is mainly used in machinery and plant construction and boasts the following qualities:

- high strength
- excellent torsional rigidity
- low weight

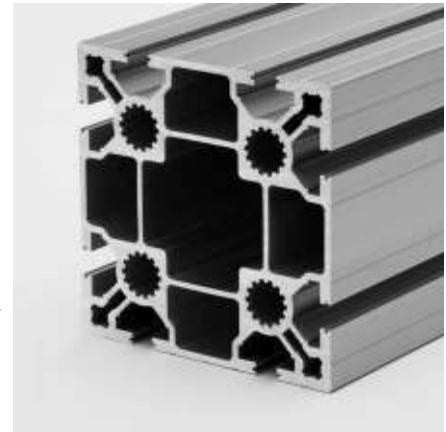

### Technical data

$I_{x,y}$	= 324.73 cm <sup>4</sup>
$W_{x,y}$	= 64.95 cm <sup>3</sup>
Cross section area	= 30.00 cm <sup>2</sup>
Weight	= 8.1 kg/m

### Order data

### Order number

100x100 base extrusion	
Standard length 5000 mm	MA2-5-00/5000
Special length 6000 mm	MA2-5-01/6000
100x100 base extrusion	
Cut to length	MA2-5-02-02/...
Extra machining	Pages 34/35



## 100x100 heavy duty extrusion type MA1-5

### Application

An extremely sturdy extrusion which is used as a support, stand or manifold. Ideal for building gantries if used in combination with the 100x200 heavy duty extrusion, MA1-9.

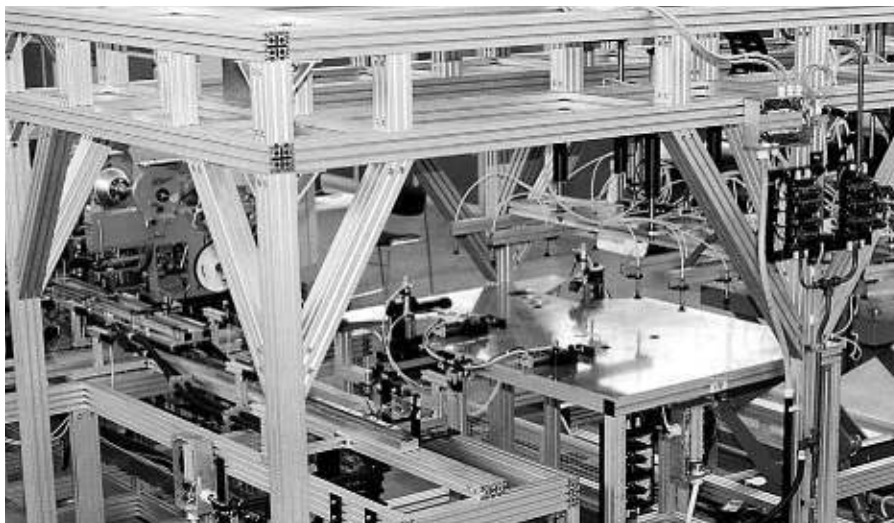
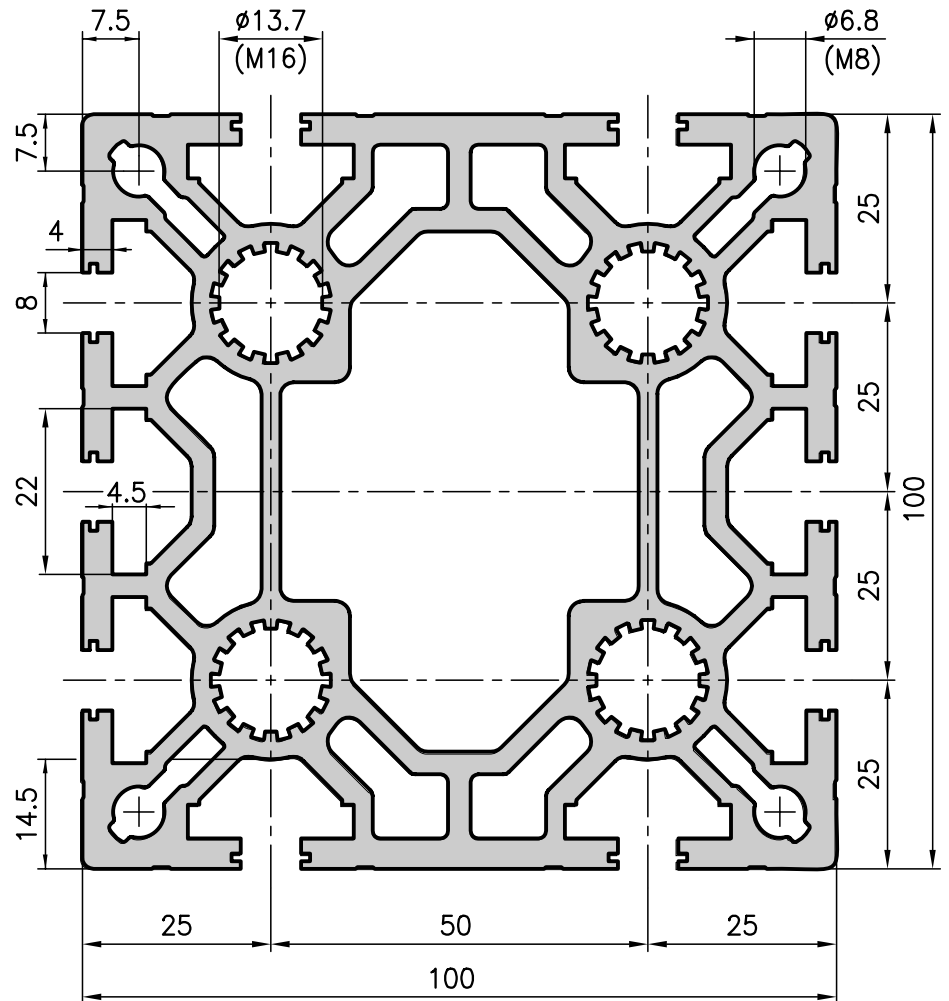
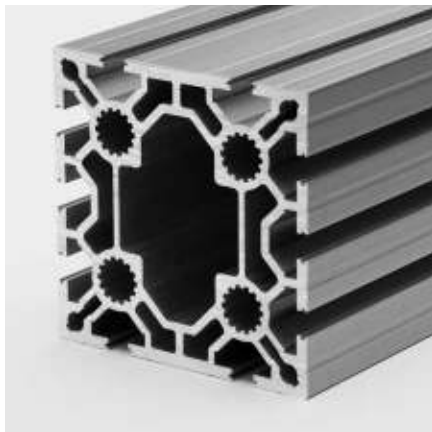

### Technical data

$I_x$	=	380.00 cm <sup>4</sup>
$I_y$	=	365.00 cm <sup>4</sup>
$W_x$	=	76.00 cm <sup>3</sup>
$W_y$	=	73.00 cm <sup>3</sup>
Cross section area	=	35.19 cm <sup>2</sup>
Weight	=	9.5 kg/m

### Order data

### Order number

100x100 heavy duty extrusion	
Standard length 5000 mm	MA1-5-00/5000
Special length 6000 mm	MA1-5-01/6000
100x100 heavy duty extrusion	
Cut to length	MA1-5-02-02/...
Extra machining	Pages 34/35

## 50x150 beam extrusion type MA1-3

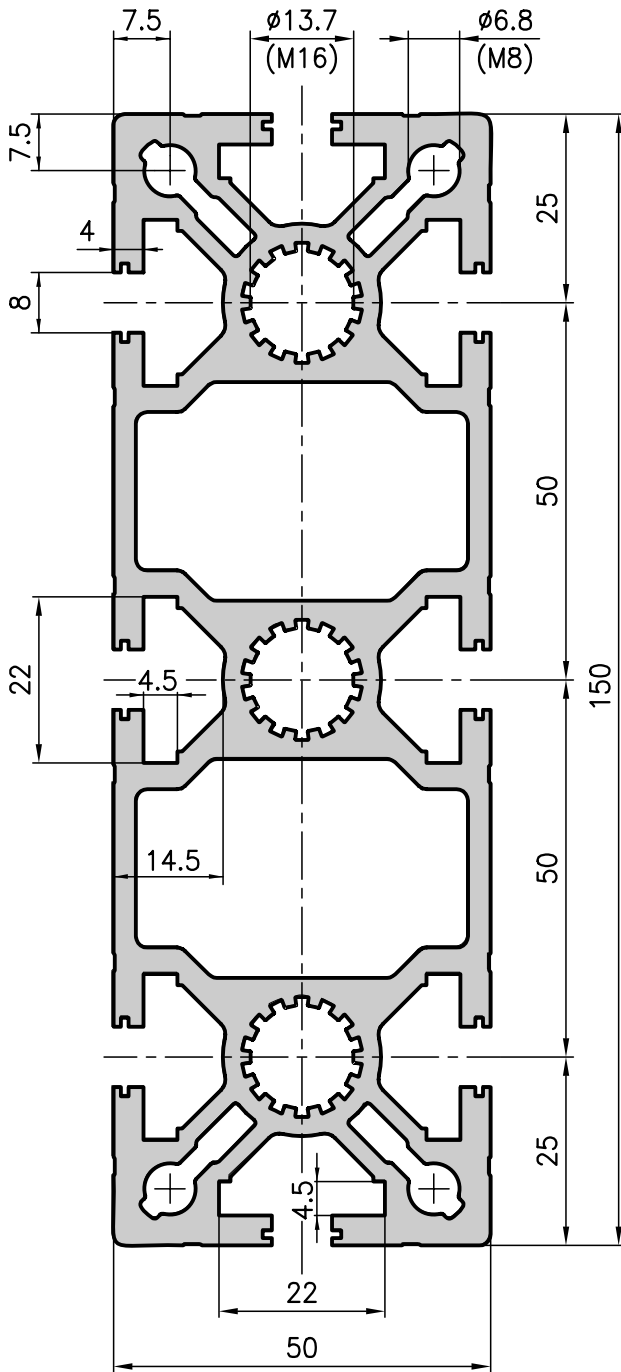

### Application

As the name suggests, this extrusion is mainly used to support heavy loads because of its excellent load-bearing characteristics. However, it is also an effective manifold extrusion.

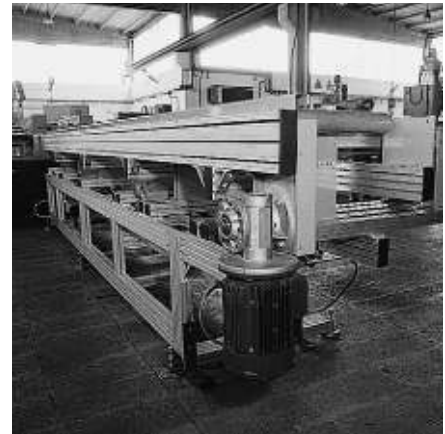
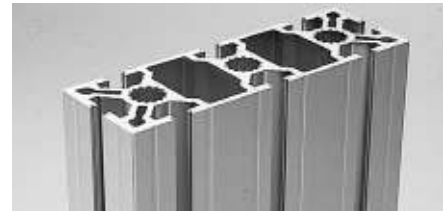

### Technical data

$I_x$	= 608.31 cm <sup>4</sup>
$I_y$	= 73.56 cm <sup>4</sup>
$W_x$	= 81.11 cm <sup>3</sup>
$W_y$	= 29.42 cm <sup>3</sup>
Cross section area	= 26.04 cm <sup>2</sup>
Weight	= 7.1 kg/m

### Order data

### Order number

50x150 bearing extrusion	
Standard length 5000 mm	MA1-3-00/5000
Special length 6000 mm	MA1-3-01/6000

50x150 bearing extrusion	
Cut to length	MA1-3-02-02/...

Extra machining	Pages 34/35
-----------------	-------------

# 100x200 heavy duty extrusion type MA1-9

### Application

Ideal for building gantries in which the supports are spaced well apart or for any application where very heavy loads have to be borne with minimal bending.

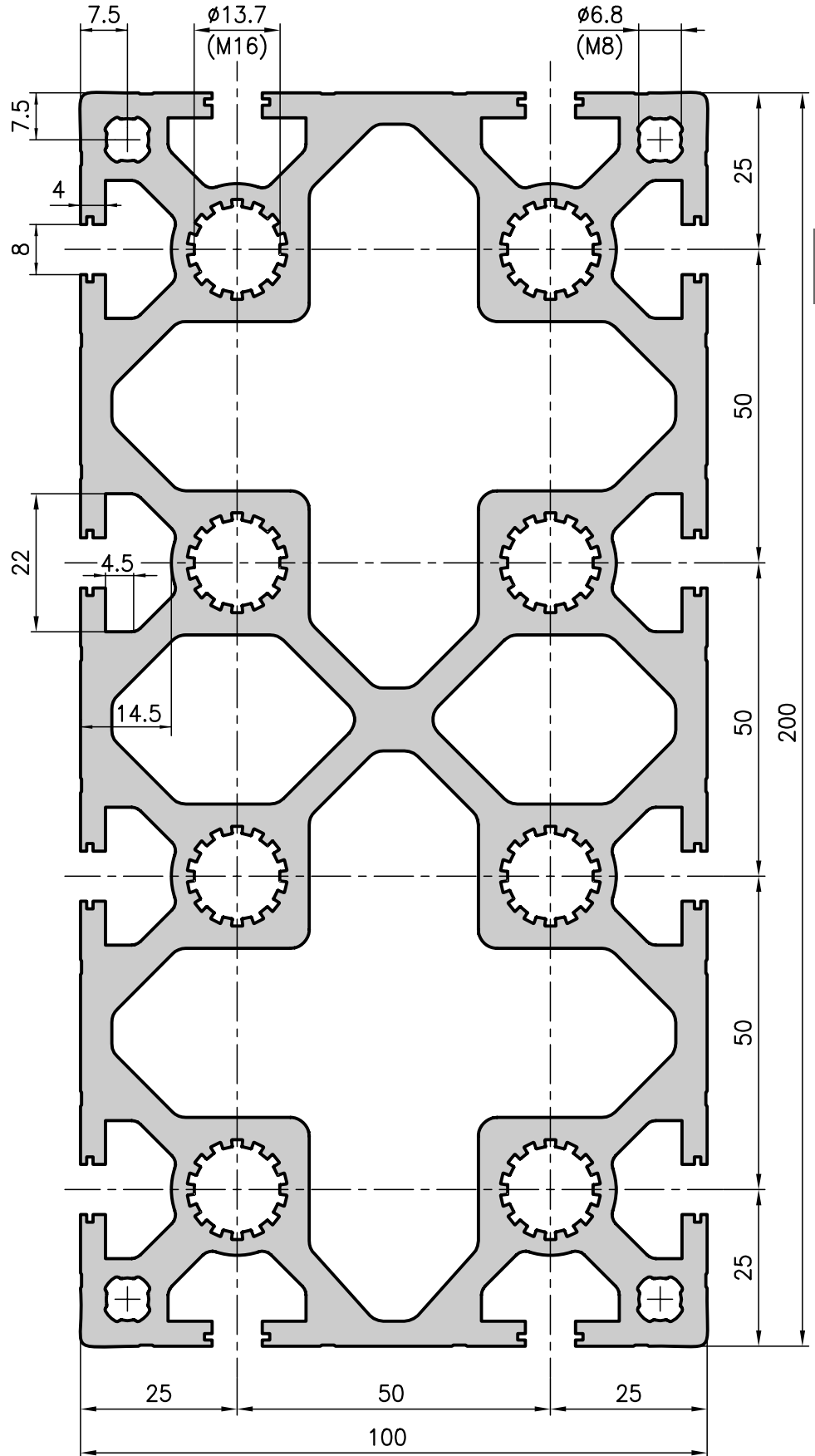
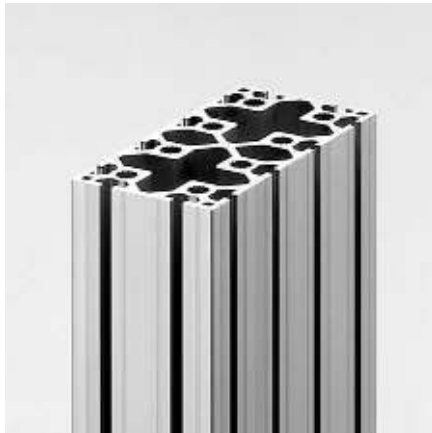

### Technical data

$I_x$	=	2442.53 cm <sup>4</sup>
$I_y$	=	718.61 cm <sup>4</sup>
$W_x$	=	244.25 cm <sup>3</sup>
$W_y$	=	143.72 cm <sup>3</sup>
Cross section area	=	62.90 cm <sup>2</sup>
Weight	=	17.0 kg/m

### Order data

### Order number

100x200 heavy duty extrusion	
Standard length 5000 mm	MA1-9-00/5000
Special length 6000 mm	MA1-9-01/6000
100x200 heavy duty extrusion	
Cut to length	MA1-9-02-02/...
Extra machining	Pages 34/35

### 40x40 super lightweight extrusion type C03-1

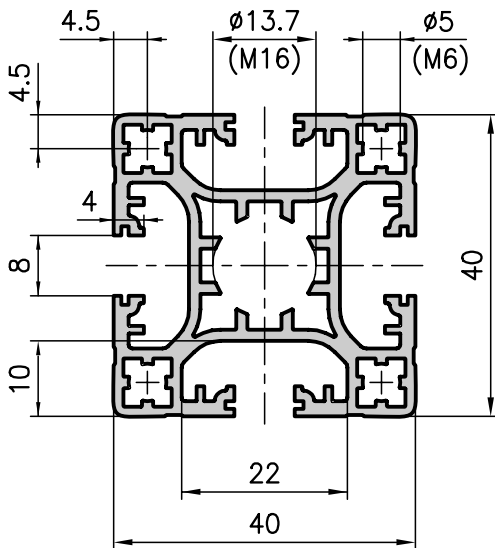

### 40x40 lightweight extrusion type C02-1

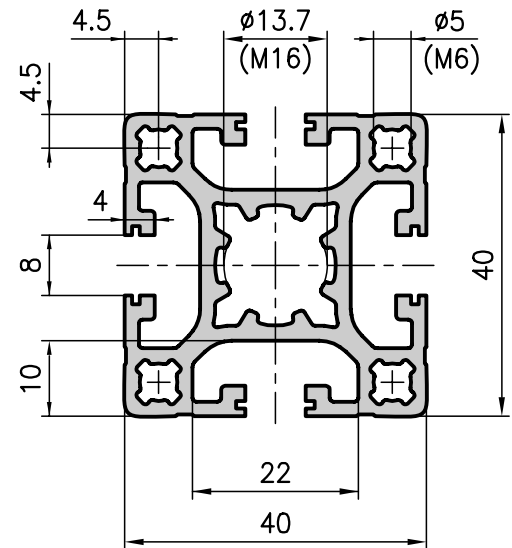

#### Application

These lightweight extrusions help to keep costs down! They can be used to create lightweight designs with excellent load-bearing capabilities.

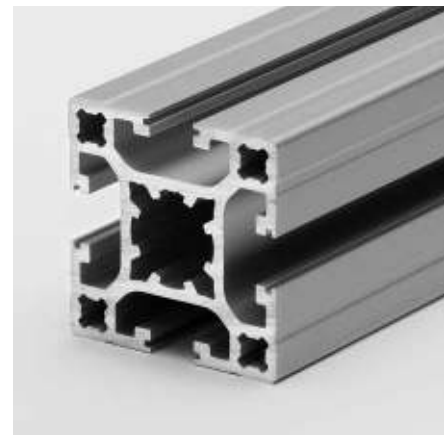

#### Technical data

$I_{x,y}$	=	8.20 cm <sup>4</sup>
$W_{x,y}$	=	4.10 cm <sup>3</sup>
Cross section area	=	4.90 cm <sup>2</sup>
Weight	=	1.3 kg/m

#### Order data

#### Order number

40x40 super lightweight extrusion	
Standard length 5000 mm	C03-1-00/5000
40x40 super lightweight extrusion	
Cut to length	C03-1-02-02/...
Extra machining	Pages 34/35

#### Technical data

$I_{x,y}$	=	9.35 cm <sup>4</sup>
$W_{x,y}$	=	4.67 cm <sup>3</sup>
Cross section area	=	5.70 cm <sup>2</sup>
Weight	=	1.5 kg/m

#### Order data

#### Order number

40x40 lightweight extrusion	
Standard length 5000 mm	C02-1-00/5000
40x40 lightweight extrusion	
Cut to length	C02-1-02-02/...
Extra machining	Pages 34/35



### 40x40 base extrusion type C01-1

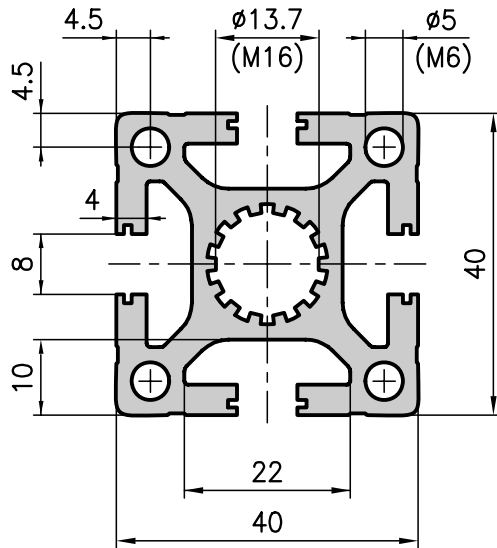

### 40x40 face extrusion type C01-8

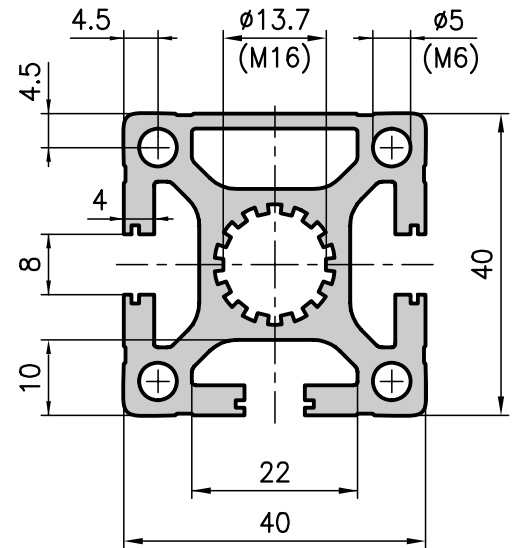

#### Application

These versatile extrusions can be used for all kinds of structures. With their 40 mm base, they complement extrusions with 20, 30 and 50 mm bases perfectly. The base extrusion itself is extraordinarily sturdy and is hard to beat in terms of value for money.

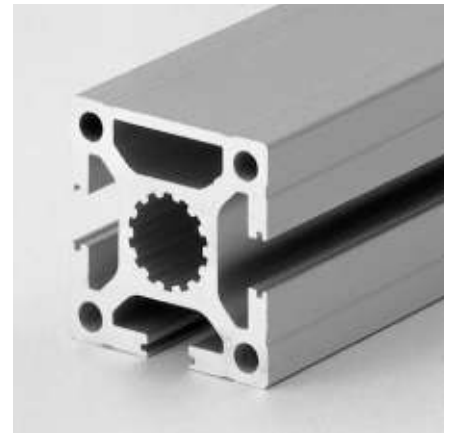

#### Technical data

$I_{x,y}$	=	11.70 cm <sup>4</sup>
$W_{x,y}$	=	5.75 cm <sup>3</sup>
Cross section area	=	7.29 cm <sup>2</sup>
Weight	=	2.0 kg/m

#### Order data      Order number

40x40 base extrusion	
Standard length 5000 mm	C01-1-00/5000
40x40 base extrusion	
Cut to length	C01-1-02-02/...
Extra machining	Pages 34/35

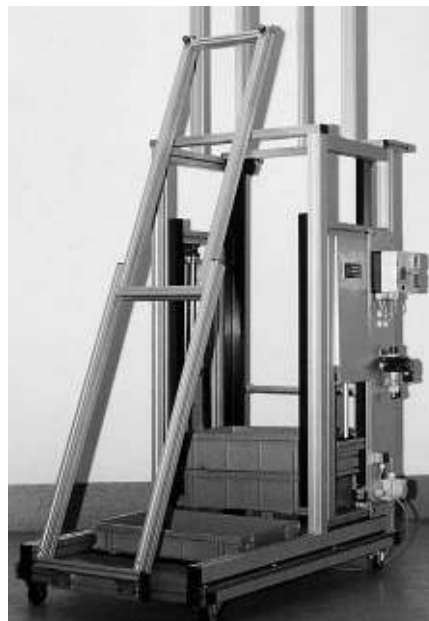

#### Technical data

$I_x$	=	11.66 cm <sup>4</sup>
$I_y$	=	11.67 cm <sup>4</sup>
$W_x$	=	5.78 cm <sup>3</sup>
$W_y$	=	5.83 cm <sup>3</sup>
Cross section area	=	7.30 cm <sup>2</sup>
Weight	=	2.0 kg/m

#### Order data      Order number

40x40 face extrusion	
Standard length 5000 mm	C01-8-00/5000
40x40 face extrusion	
Cut to length	C01-8-02-02/...
Extra machining	Pages 34/35

### 40x40 corner extrusion type C01-7

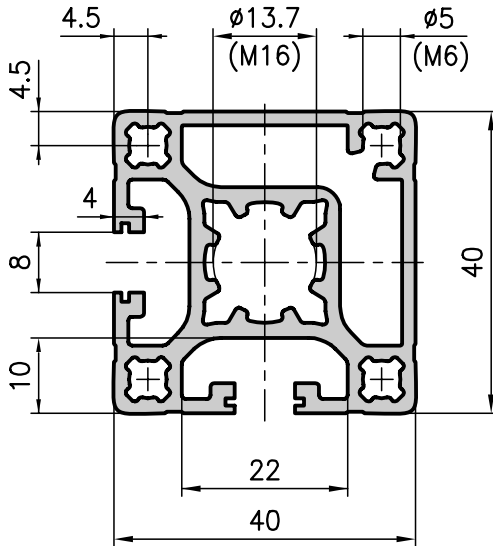

### 40x40 double face extrusion type C02-4

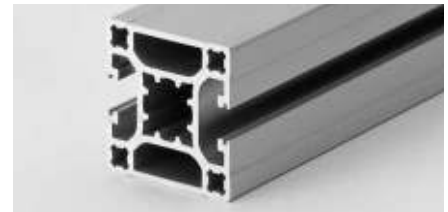
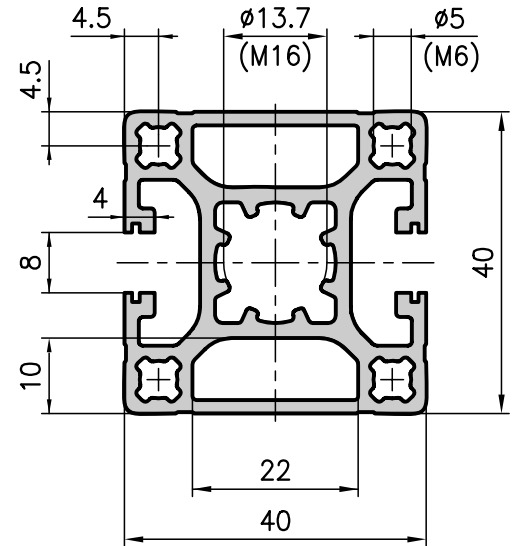

#### Application

Partially closed extrusions are particularly attractive in design, trap less dirt and can be used for a wide range of applications.

#### Application

For all types of enclosure, as well as for structures with extrusion faces which are mainly closed and for applications with an attractive design

#### Technical data

$I_{x,y}$	=	9.21 cm <sup>4</sup>
$W_{x,y}$	=	4.53 cm <sup>3</sup>
Cross section area	=	5.56 cm <sup>2</sup>
Weight	=	1.5 kg/m

#### Technical data

$I_x$	=	9.56 cm <sup>4</sup>
$I_y$	=	9.21 cm <sup>4</sup>
$W_x$	=	4.78 cm <sup>3</sup>
$W_y$	=	4.60 cm <sup>3</sup>
Cross section area	=	5.69 cm <sup>2</sup>
Weight	=	1.5 kg/m

#### Order data

#### Order number

40x40 corner extrusion	
Standard length 5000 mm	C01-7-00/5000
40x40 corner extrusion	
Cut to length	C01-7-02-02/...
Extra machining	Pages 34/35

#### Order data

#### Order number

40x40 double face extrusion	
Standard length 5000 mm	C02-4-00/5000
40x40 double face extrusion	
Cut to length	C02-4-02-02/...
Extra machining	Pages 34/35



### 40x40 face extrusion with rip off slots type CE2-2

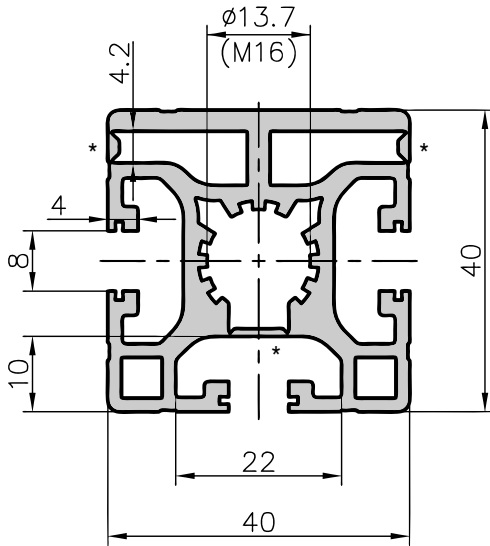

### 40x40 corner extrusion with rip off slots type CE1-3

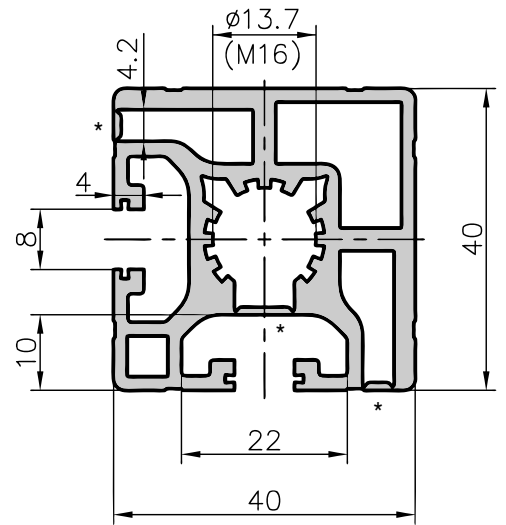

\* Rip off slot

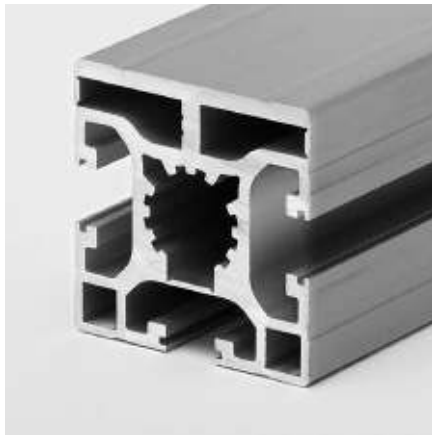

#### Application

These two extrusion are with rip off slots to allow you to insert panels. The cross section is for using the new connecting technology.



#### Technical data

Ix	=	9.78 cm <sup>4</sup>
Iy	=	8.77 cm <sup>4</sup>
Wx	=	4.59 cm <sup>3</sup>
Wy	=	4.39 cm <sup>3</sup>
Cross section area	=	5.95 cm <sup>2</sup>
Weight	=	1.6 kg/m

#### Order data      Order number

40x40 face extrusion with rip off slot	
Standard length 5000mm	CE2-2-00/5000
40x40 face extrusion with rip off slot	
Cut to length	CE2-2-02-02/...
Extra machining	Pages 34/35



#### Technical data

Ix	=	9.07 cm <sup>4</sup>
Iy	=	8.98 cm <sup>4</sup>
Wx	=	4.52 cm <sup>3</sup>
Wy	=	4.48 cm <sup>3</sup>
Cross section area	=	5.84 cm <sup>2</sup>
Weight	=	1.6 kg/m

#### Order data      Order number

40x40 corner Extrusion with rip off slots	
Standard length 5000 mm	CE1-3-00/5000
40x40 corner extrusion with rip off slots	
Cut to length	CE1-3-02-02/...
Extra machining	Pages 34/35

### 40x40 four sided extrusion type CE1-0

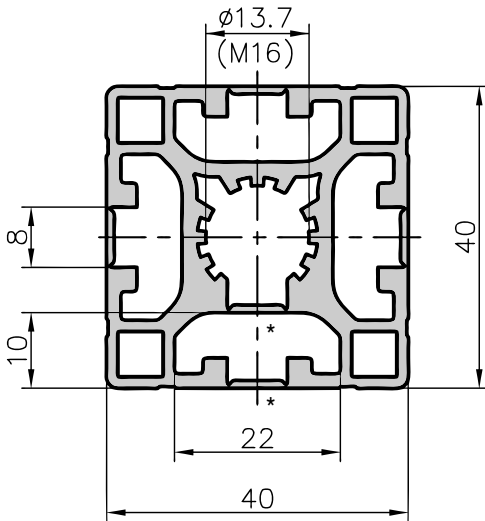

\* Rip off slot

### Corner extrusion 45° type CE4-4

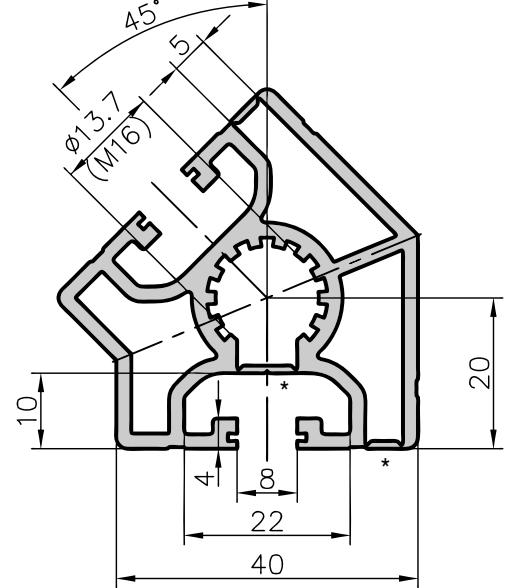

#### Application

Mostly used in clean-room application, where slots are not desired. Thanks to the rip off slots, they can still be used universally.

#### Application

Used for mitered constructions or as angle element for 45° connections.

#### Technical data

I <sub>x</sub>	=	9.41 cm <sup>4</sup>
I <sub>y</sub>	=	9.30 cm <sup>4</sup>
W <sub>x</sub>	=	4.71 cm <sup>3</sup>
W <sub>y</sub>	=	4.66 cm <sup>3</sup>
Cross section area	=	5.90 cm <sup>2</sup>
Weight	=	1.6 kg/m

#### Order data      Order number

40x40 four sided extrusion	
Standard length 5000 mm	CE1-0-00/5000
40x40 four sided extrusion	
Cut to length	CE1-0-02-02/...
Extra machining	Pages 34/35

#### Technical data

I <sub>x</sub>	=	9.08 cm <sup>4</sup>
I <sub>y</sub>	=	8.33 cm <sup>4</sup>
W <sub>x</sub>	=	3.43 cm <sup>3</sup>
W <sub>y</sub>	=	2.98 cm <sup>3</sup>
Cross section area	=	5.35 cm <sup>2</sup>
Weight	=	1.4 kg/m

#### Order data      Order number

40x40 corner extrusion 45°	
Standard length 5000 mm	CE4-4-00/5000
40x40 corner extrusion 45°	
Cut to length	CE4-4-02-02/...
Extra machining	Pages 34/35



### 40x45° angle extrusion type C02-8

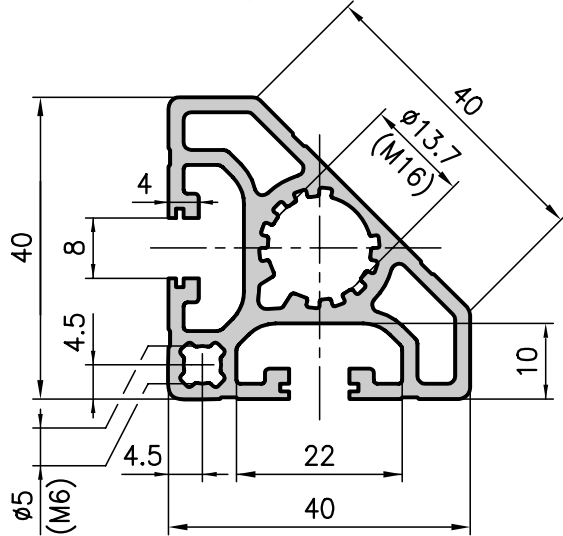

#### Application

The C02-8 type angle extrusion allows you to create attractive, soft contours and has the versatility to be used for all sorts of structural designs.

#### Technical data

$I_{x,y}$	=	6.30 cm <sup>4</sup>
$W_{x,y}$	=	2.70 cm <sup>3</sup>
Cross section area	=	4.57 cm <sup>2</sup>
Weight	=	1.2 kg/m

#### Order data      Order number

40x45° angle extrusion	
Standard length 5000 mm	C02-8-00/5000
40x45° angle extrusion	
Cut to length	C02-8-02-02/...
Extra machining	Pages 34/35

### Softline extrusion 40x40 type C03-8

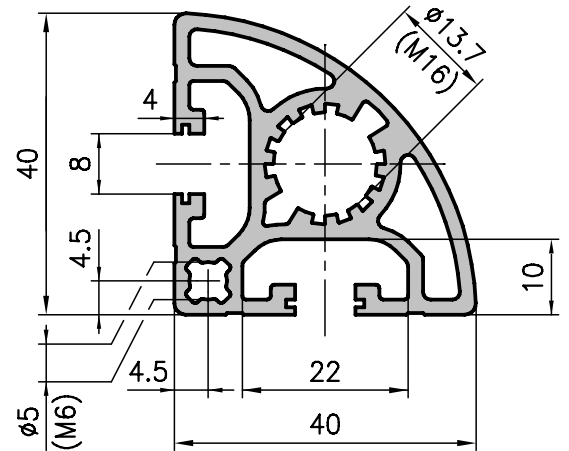

#### Application

Worktables, furniture, display cabinets, picture frames and applications where sharp corners must be avoided

#### Technical data

$I_{x,y}$	=	6.70 cm <sup>4</sup>
$W_{x,y}$	=	2.97 cm <sup>3</sup>
Cross section area	=	4.90 cm <sup>2</sup>
Weight	=	1.3 kg/m

#### Order data      Order number

Softline extrusion	
Standard length 5000 mm	C03-8-00/5000
Softline extrusion	
Cut to length	C03-8-02-02/...
Extra machining	Pages 34/35



### 40x80 light extrusion type C02-3

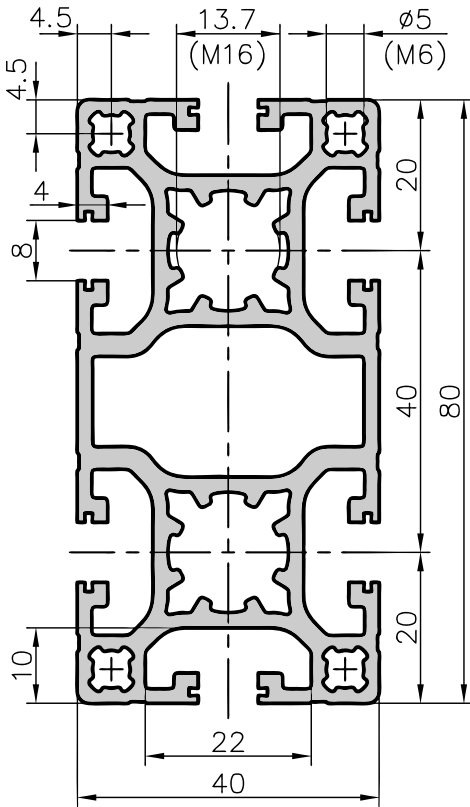

#### Application

These extrusions can be used to hold liquids and gases, to bear loads, to take threads and lots more. They can be a perfect solution to very specific problems. They can be combined with 20, 30 and 50 series extrusions, which means that you can genuinely build on this design of extrusion.

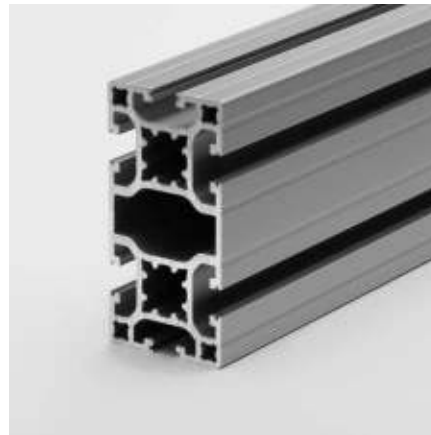

### 40x80 base extrusion type C01-3

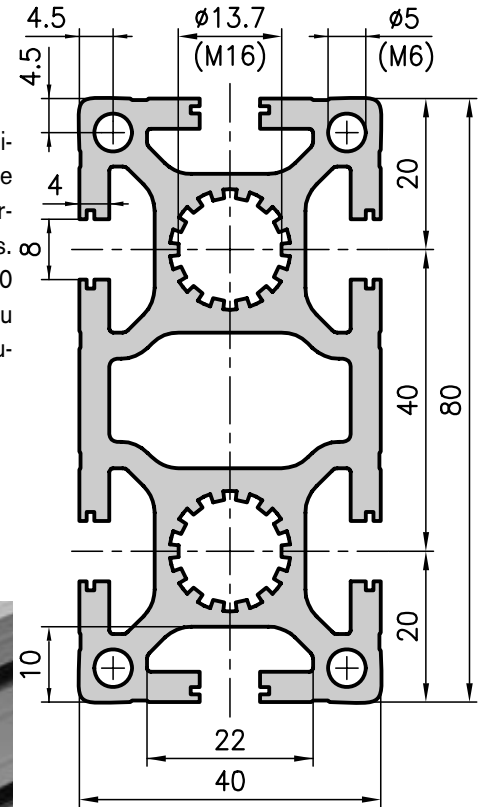

#### Technical data

$I_x$	=	64.90 cm <sup>4</sup>
$I_y$	=	17.70 cm <sup>4</sup>
$W_x$	=	16.23 cm <sup>3</sup>
$W_y$	=	8.85 cm <sup>3</sup>
Cross section area	=	10.20 cm <sup>2</sup>
Weight	=	2.8 kg/m

#### Order data Order number

40x80 light extrusion	
Standard length 5000 mm	C02-3-00/5000
40x80 light extrusion	
Cut to length	C02-3-02-02/...
Extra machining	Pages 34/35

#### Technical data

$I_x$	=	81.95 cm <sup>4</sup>
$I_y$	=	22.74 cm <sup>4</sup>
$W_x$	=	20.49 cm <sup>3</sup>
$W_y$	=	11.37 cm <sup>3</sup>
Cross section area	=	13.50 cm <sup>2</sup>
Weight	=	3.7 kg/m

#### Order data Order number

40x80 base extrusion	
Standard length 5000 mm	C01-3-00/5000
40x80 base extrusion	
Cut to length	C01-3-02-02/...
Extra machining	Pages 34/35



### 40x80 face extrusion type C01-5

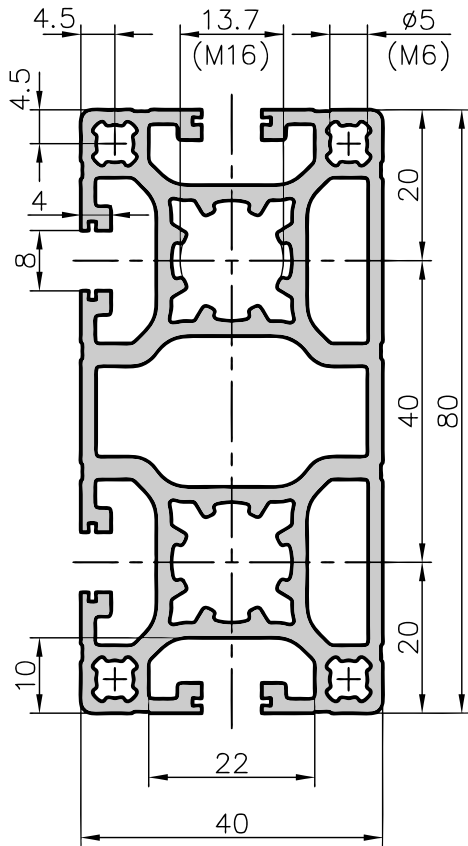

**Application**

Like all partially closed extrusions, this item is ideal if you want to keep your structure as clean as possible.

**Technical data**

I <sub>x</sub>	=	64.40 cm <sup>4</sup>
I <sub>y</sub>	=	17.20 cm <sup>4</sup>
W <sub>x</sub>	=	16.10 cm <sup>3</sup>
W <sub>y</sub>	=	8.60 cm <sup>3</sup>
Cross section area	=	9.76 cm <sup>2</sup>
Weight	=	2.6 kg/m

**Order data      Order number**

40x80 face extrusion	
Standard length 5000 mm	C01-5-00/5000
40x80 face extrusion	
Cut to length	C01-5-02-02/...
Extra machining	Pages 34/35

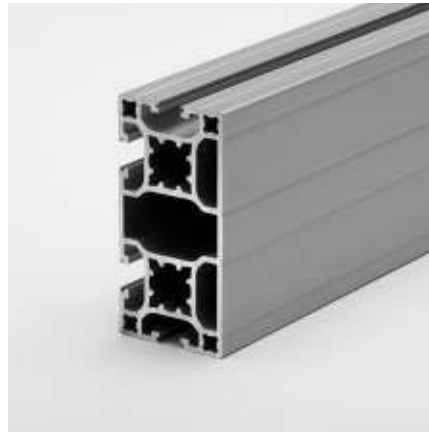

### 40x120 light extrusion type CE1-9

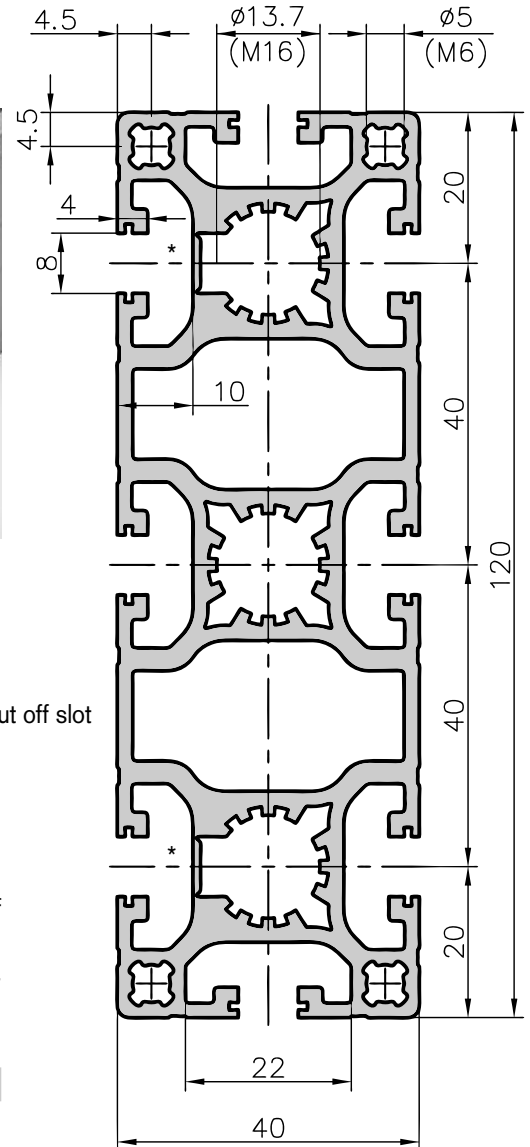

**Application**

The light extrusion 40x120 with the rip off slots for use with the new connecting technology, PVS®-EASY, is a cost effective cross beam.

**Technical data**

I <sub>x</sub>	=	205.74 cm <sup>4</sup>
I <sub>y</sub>	=	25.74 cm <sup>4</sup>
W <sub>x</sub>	=	34.29 cm <sup>3</sup>
W <sub>y</sub>	=	12.86 cm <sup>3</sup>
Cross section area	=	14.91 cm <sup>2</sup>
Weight	=	4.02 kg/m

**Order data      Order number**

40x120 light extrusion	
Standard length 5000 mm	CE1-9-00/5000
40x120 light extrusion	
Cut to length	CE1-9-02-02/...
Extra machining	Pages 34/35

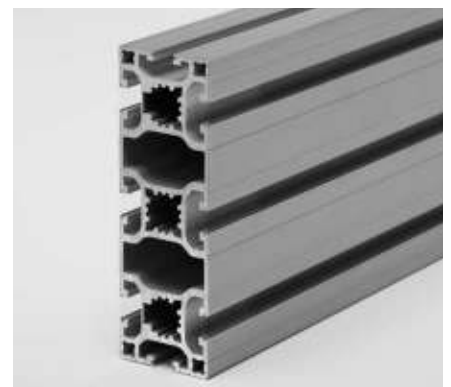

## 40x120 beam extrusion type C01-9

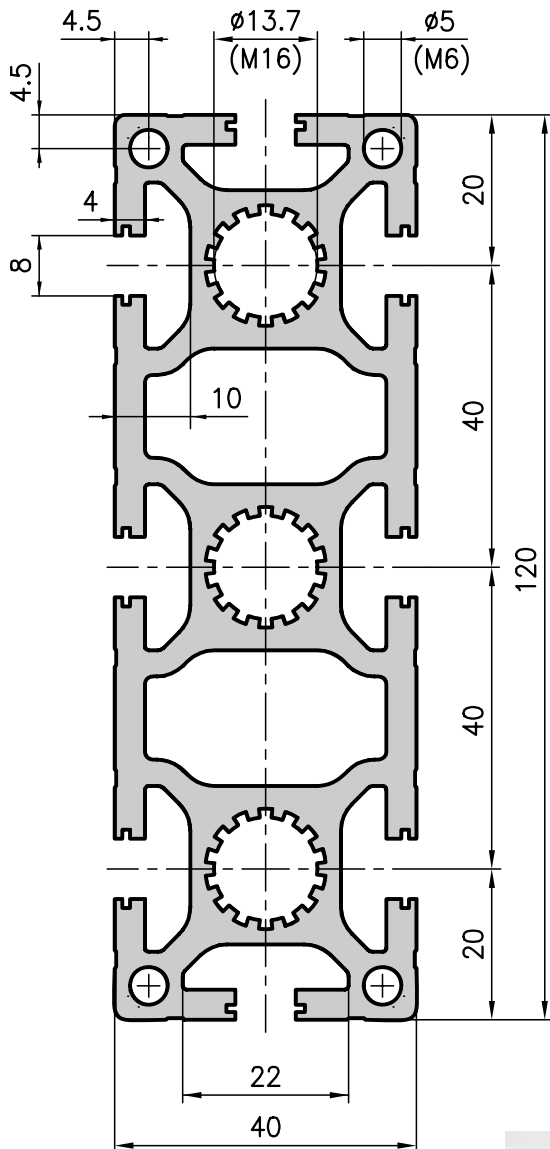

### Application

The C01-9 extrusion has the same properties as the MA1-3 bearing extrusion (50x150), with slightly lower load-bearing capability.

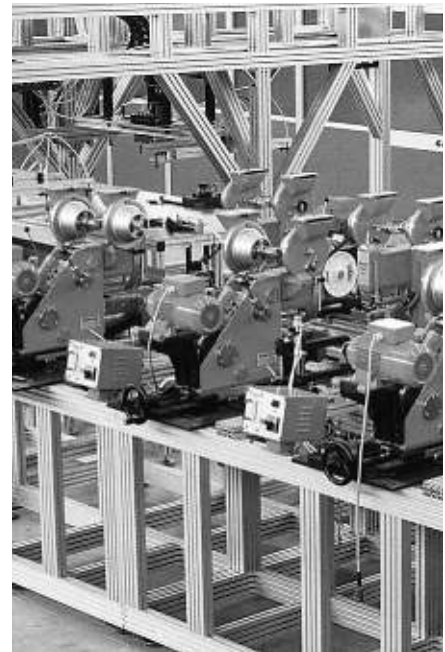

### Technical data

$I_x$	= 258.52 cm <sup>4</sup>
$I_y$	= 33.43 cm <sup>4</sup>
$W_x$	= 43.09 cm <sup>3</sup>
$W_y$	= 16.72 cm <sup>3</sup>
Cross section area	= 19.63 cm <sup>2</sup>
Weight	= 5.3 kg/m

### Order data

### Order number

40x120 bearing extrusion	
Standard length 5000 mm	C01-9-00/5000
Special length 6000 mm	C01-9-01/6000
40x120 bearing extrusion	
Cut to length	C01-9-02-02/...
Extra machining	Pages 34/35

## 40x160 beam extrusion type C02-9

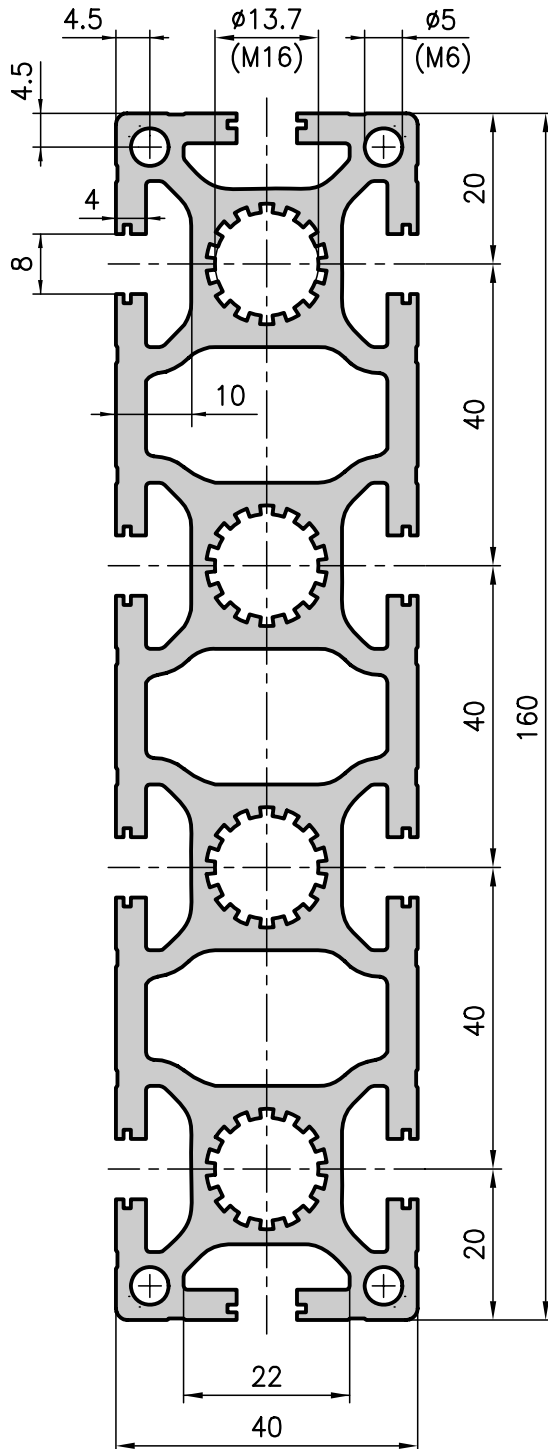

### Application

This versatile extrusion is particularly useful for structures which are subjected to heavy loads and which span large widths. It can also be used as a multiple supply line for a variety of media.



### Technical data

$I_x$	= 592.79 cm <sup>4</sup>
$I_y$	= 44.36 cm <sup>4</sup>
$W_x$	= 74.09 cm <sup>3</sup>
$W_y$	= 22.18 cm <sup>3</sup>
Cross section area	= 25.83 cm <sup>2</sup>
Weight	= 7.0 kg/m

### Order data

### Order number

40x160 bearing extrusion	
Standard length 5000 mm	C02-9-00/5000
Special length 6000 mm	C02-9-01/6000
40x160 bearing extrusion	
Cut to length	C02-9-02-02/...
Extra machining	Pages 34/35

## 80x80x40 L-shaped extrusion type C01-6

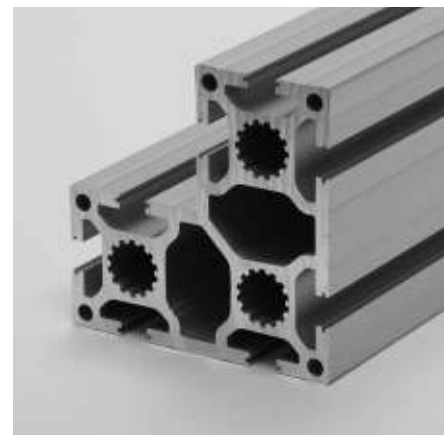
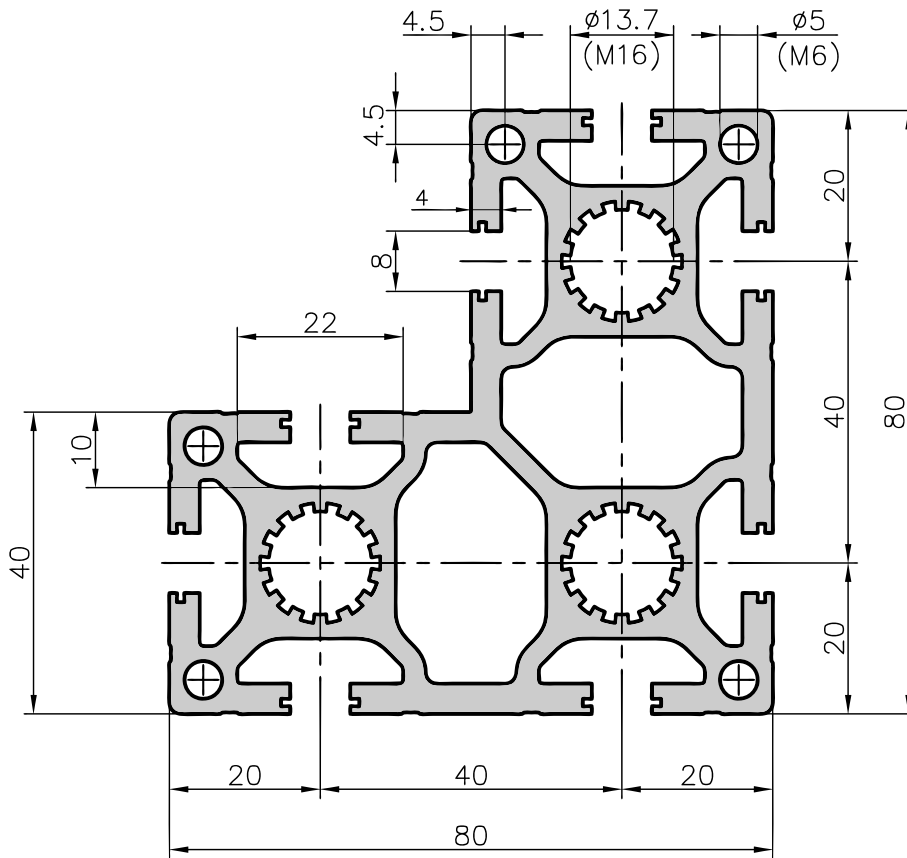

### Technical data

$I_{x,y}$	= 109.18 cm <sup>4</sup>
$W_{x,y}$	= 23.56 cm <sup>3</sup>
Cross section area	= 19.59 cm <sup>2</sup>
Weight	= 5.3 kg/m

### Application

For machine and apparatus frames which have to hold heavy weights and which require strong corner components. They will also be compact and inexpensive.

### Order data

### Order number

80x80x40 angle extrusion	
Standard length 5000 mm	C01-6-00/5000
80x80x40 angle extrusion	
Cut to length	C01-6-02-02/...
Extra machining	Pages 34/35

### 80x80 base extrusion type C01-4

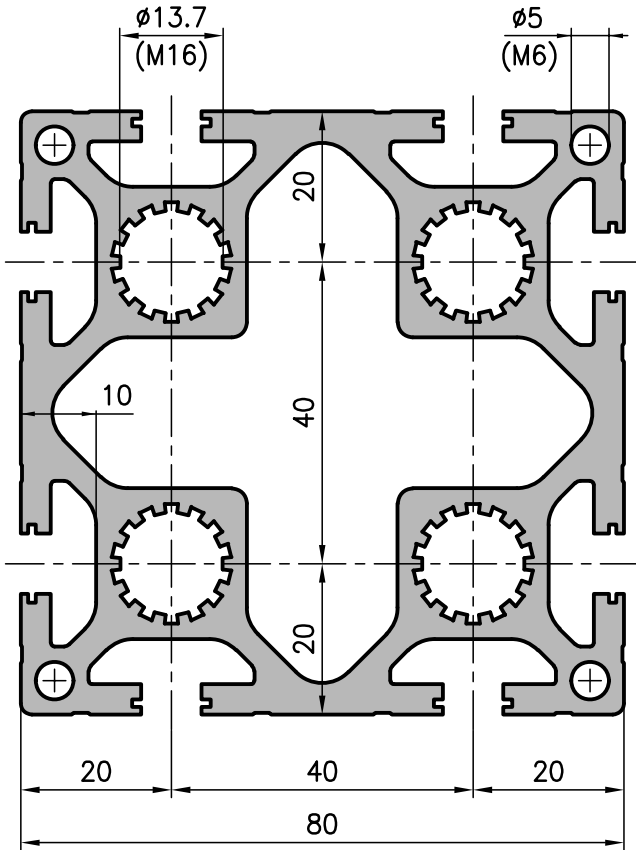

#### Application

This is mainly used as a support, although it can also be used as a cross-beam where higher loads are involved. Especially C01-4 is, of course, also ideal as a reservoir for liquids or gases. The large cavity can also be used effectively for holding load balancing weights. This extrusion is perfect for innovative designers.



### 80x80 lightweight extrusion type C03-4

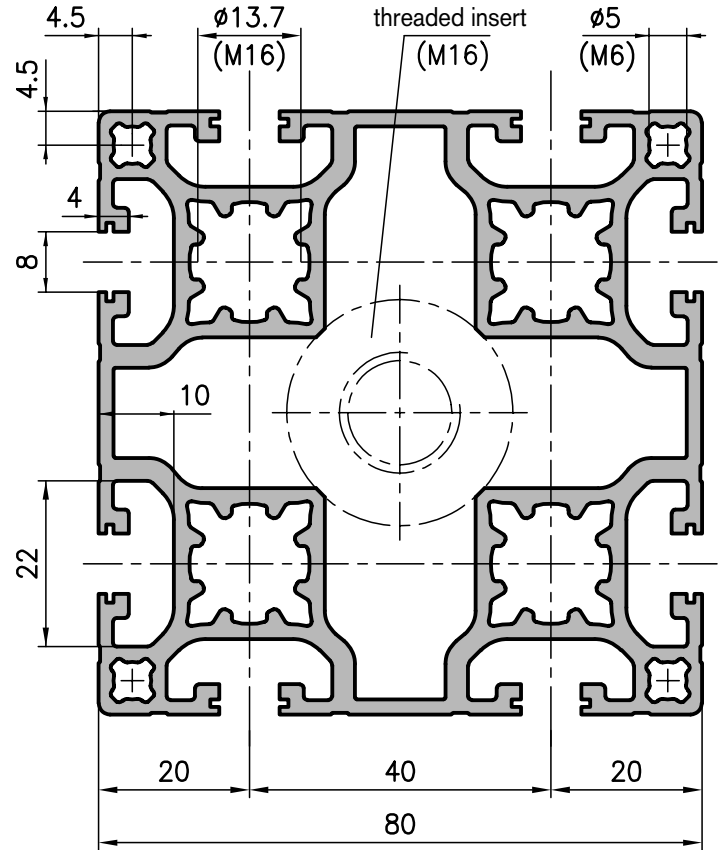

#### Technical data

$I_{x,y}$	=	154.70 cm <sup>4</sup>
$W_{x,y}$	=	38.68 cm <sup>3</sup>
Cross section area	=	22.10 cm <sup>2</sup>
Weight	=	6.0 kg/m

#### Order data Order number

80x80 base extrusion	
Standard length 5000 mm	C01-4-00/5000
Special length 6000 mm	C01-4-01/6000
80x80 base extrusion	
Cut to length	C01-4-02-02/...
Extra machining	Pages 34/35

#### Technical data

$I_{x,y}$	=	115.66 cm <sup>4</sup>
$W_{x,y}$	=	28.92 cm <sup>3</sup>
Cross section area	=	16.30 cm <sup>2</sup>
Weight	=	4.4 kg/m

#### Order data Order number

Lightweight extrusion 80x80	
Standard length 5000 mm	C03-4-00/5000
Special length 6000 mm	C03-4-01/6000
Lightweight extrusion 80x80	
Cut to length	C03-4-02-02/...
Extra machining	Pages 34/35

## Beam extrusion 80x120 type MC1-2

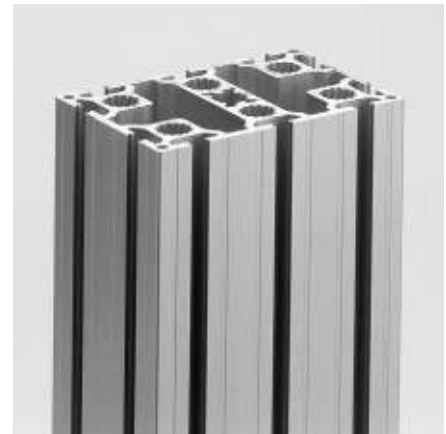
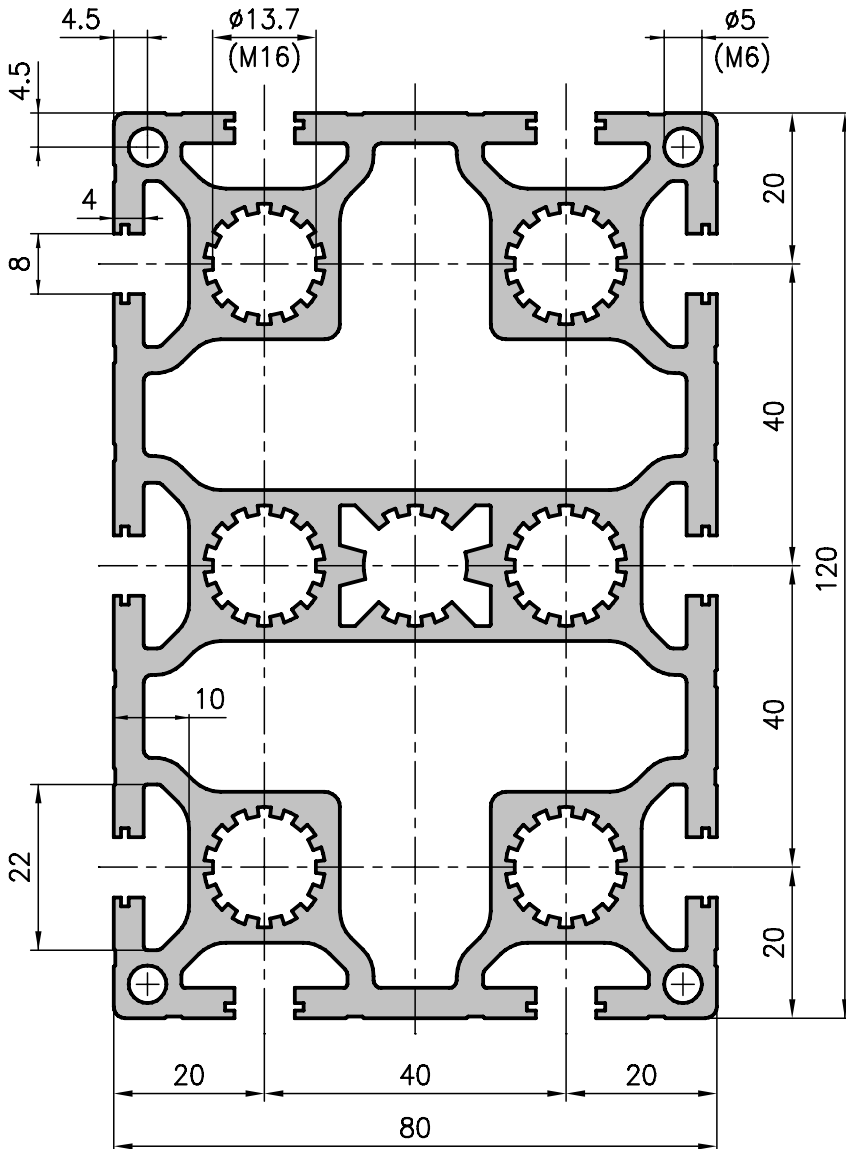

### Application

A universally useful extrusion with optimum static strength for large gantries and constructions under heavy load.

### Technical data

$I_x$	=	451.20 cm <sup>4</sup>
$I_y$	=	219.76 cm <sup>4</sup>
$W_x$	=	75.20 cm <sup>3</sup>
$W_y$	=	54.94 cm <sup>3</sup>
Cross section area	=	31.07 cm <sup>2</sup>
Weight	=	8.40 kg/m

### Order data

### Order number

Beam extrusion	
Standard length 5000 mm	MC1-2-00/5000
Special length 6000 mm	MC1-2-01/6000
Beam extrusion	
Cut to length	MC1-2-02-02/...
Extra machining	Pages 34/35

## 80x160 heavy duty extrusion type MC1-9

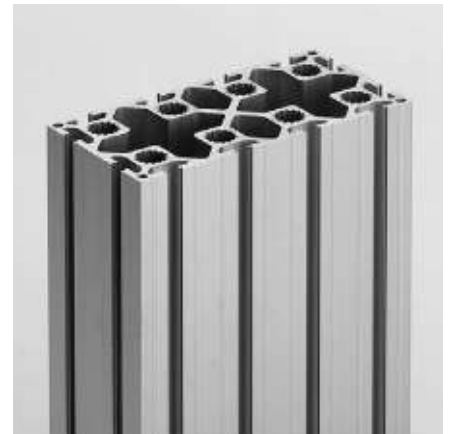
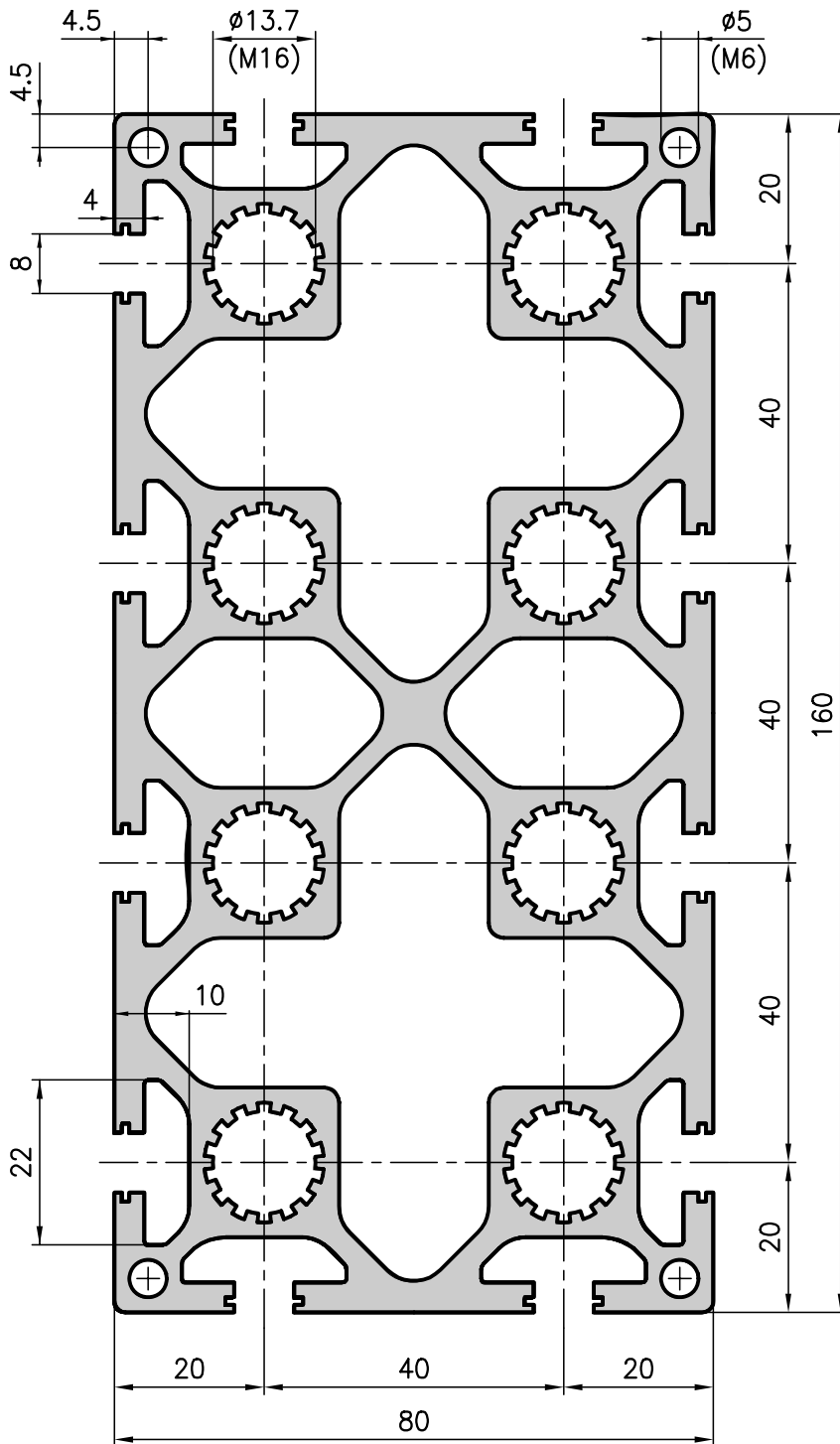

### Application

This high strength extrusion is used for the construction of gantries and for structures which have to support a heavy load or which have long unsupported sections.

### Technical data

$I_x$	= 1018.98 cm <sup>4</sup>
$I_y$	= 296.53 cm <sup>4</sup>
$W_x$	= 112.37 cm <sup>3</sup>
$W_y$	= 74.13 cm <sup>3</sup>
Cross section area	= 40.82 cm <sup>2</sup>
Weight	= 11.0 kg/m

### Order data

### Order number

80x160 heavy duty extrusion	
Standard length 5000 mm	MC1-9-00/5000
Special length 6000 mm	MC1-9-01/6000

80x160 heavy duty extrusion	
Cut to length	MC1-9-02-02/...

Extra machining	Pages 34/35
-----------------	-------------

### 30x30 super lightweight extrusion type B03-1

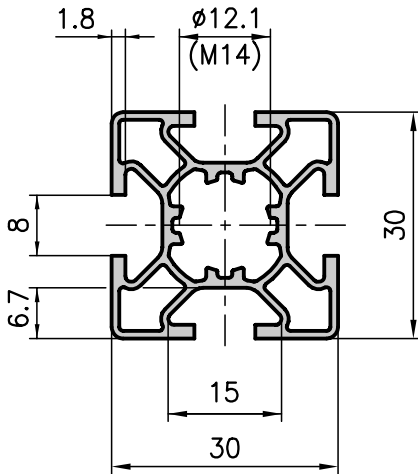

### 30x30 lightweight extrusion type B02-1

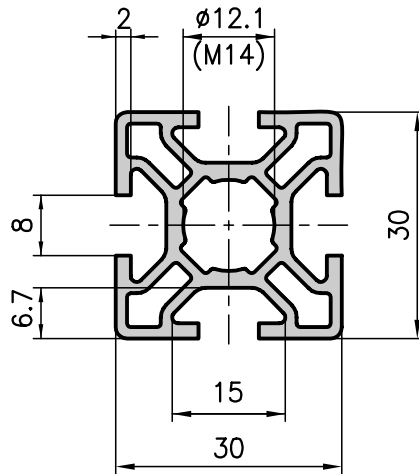

### 30x30 heavy duty extrusion type MB1-1

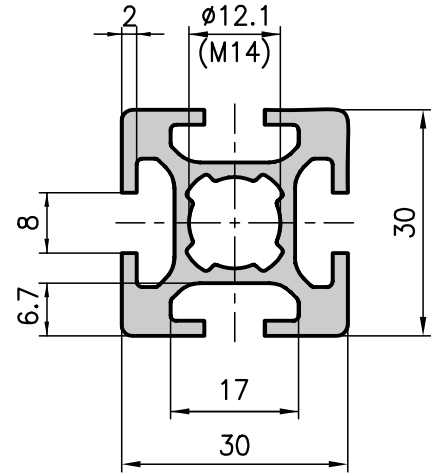

#### Application

These extrusions, which are lightweight and inexpensive, are nonetheless very sturdy and are versatile solutions for simpler structural designs. Outer casings, safety guards, laboratory rigs and smaller frameworks are all easy to construct using them.

PVS connectors fit into the centre hole of  $\varnothing 12$  mm, which can also be tapped M14 for B33-20/-6-/-28 type threaded inserts.

#### Application

The counterpart to the lightweight profile. It gives the designer plenty of scope for designing trolleys, machine frames and load-bearing structures, etc.

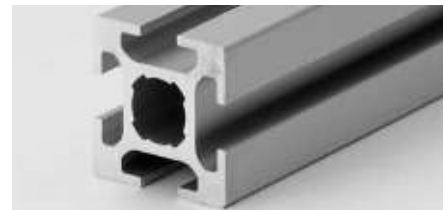
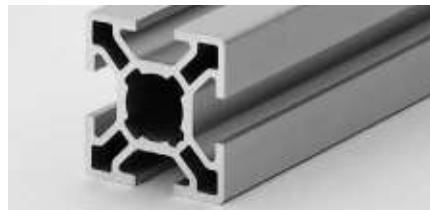

#### Technical data

$I_{x,y}$	=	2.63 cm <sup>4</sup>
$W_{x,y}$	=	1.76 cm <sup>3</sup>
Cross section area	=	2.62 cm <sup>2</sup>
Weight	=	0.7 kg/m

#### Technical data

$I_{x,y}$	=	2.95 cm <sup>4</sup>
$W_{x,y}$	=	1.97 cm <sup>3</sup>
Cross section area	=	3.27 cm <sup>2</sup>
Weight	=	0.9 kg/m

#### Technical data

$I_{x,y}$	=	3.77 cm <sup>4</sup>
$W_{x,y}$	=	2.51 cm <sup>3</sup>
Cross section area	=	4.10 cm <sup>2</sup>
Weight	=	1.1 kg/m

#### Order data

#### Order number

30x30 super lightweight extrusion  
Standard length 5000 mm B03-1-00/5000

30x30 super lightweight extrusion  
Cut to length B03-1-02-02/...

Extra machining Pages 34/35

#### Order data

#### Order number

30x30 lightweight extrusion  
Standard length 5000 mm B02-1-00/5000

30x30 lightweight extrusion  
Cut to length B02-1-02-02/...

Extra machining Pages 34/35

#### Order data

#### Order number

30x30 heavy duty extrusion  
Standard length 5000 mm MB1-1-00/5000

30x30 heavy duty extrusion  
Cut to length MB1-1-02-02/...

Extra machining Pages 34/35

### 30x30 face extrusion type B03-2

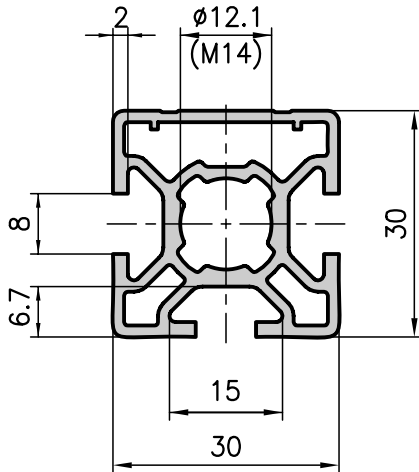

### 30x30 face extrusion with panel slots type B02-2

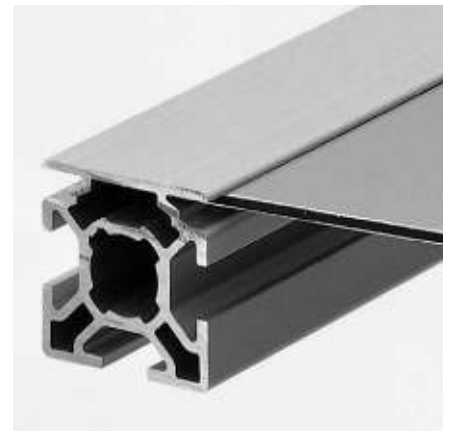
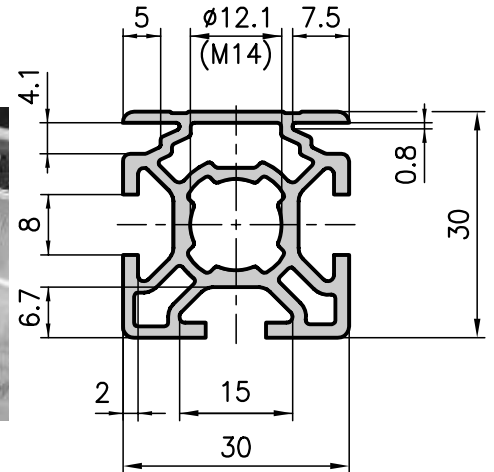

#### Application

For lightweight machine frames, protective guards, safety fencing, etc. Metal paneling sheets, as well as composite panels, acrylic glass panels and all-plastic panels up to 4 mm in thickness can be fixed in place into the panel slots on the face extrusions.

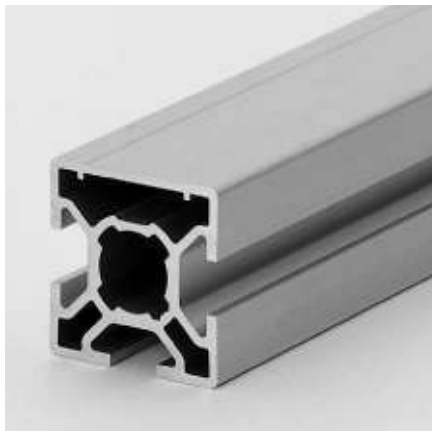

#### Technical data

$I_x$	=	2.85 cm <sup>4</sup>
$I_y$	=	2.83 cm <sup>4</sup>
$W_x$	=	1.90 cm <sup>3</sup>
$W_y$	=	1.83 cm <sup>3</sup>
Cross section area	=	3.10 cm <sup>2</sup>
Weight	=	0.8 kg/m

#### Order data      Order number

30x30 face extrusion	
Standard length 5000 mm	B03-2-00/5000
30x30 face extrusion	
Cut to length	B03-2-02-02/...
Extra machining	Pages 34/35



#### Technical data

$I_x$	=	2.93 cm <sup>4</sup>
$I_y$	=	2.76 cm <sup>4</sup>
$W_x$	=	1.93 cm <sup>3</sup>
$W_y$	=	1.84 cm <sup>3</sup>
Cross section area	=	3.18 cm <sup>2</sup>
Weight	=	0.9 kg/m

#### Order data      Order number

30x30 face enclosure extrusion	
Standard length 5000 mm	B02-2-00/5000
30x30 face enclosure extrusion	
Cut to length	B02-2-02-02/...
Extra machining	Pages 34/35

### 30x30 corner extrusion type B02-3

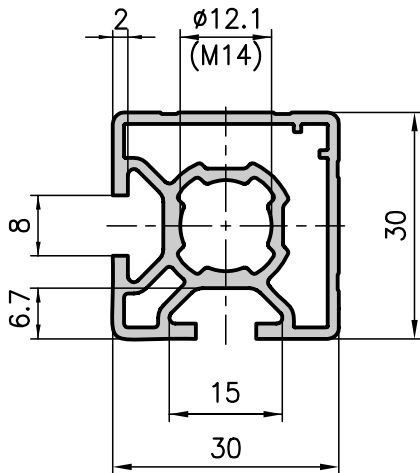

### 30x30 corner extrusion with panel slots type B01-3

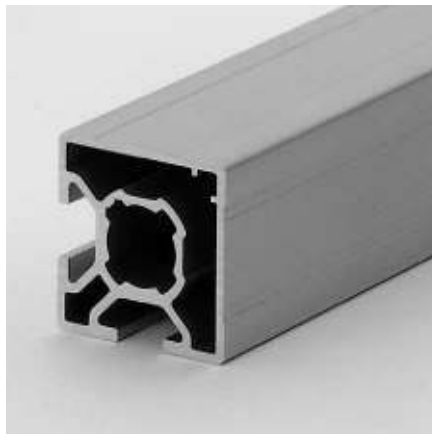
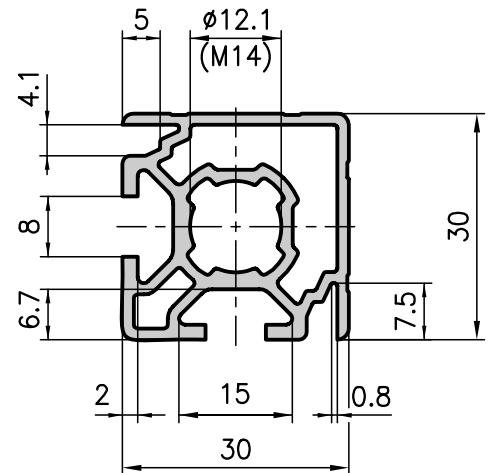

#### Application

Workstation design, enclosures, apparatus trolleys and more lightweight structures. This corner profile looks extremely compact because it is closed on two sides and is the natural choice in any application where only two slots are required for joining components together. Metal and/or composite panels are easy to fit as enclosure elements thanks to the additional panel slots.

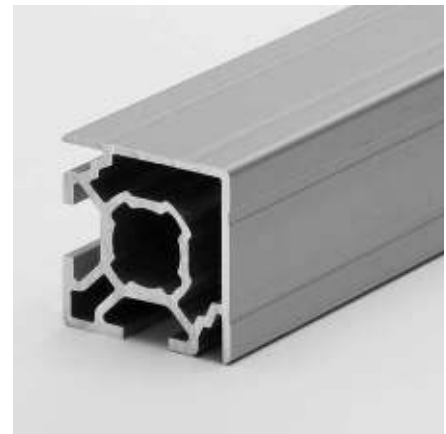

#### Technical data

$I_{x,y}$	=	2.70 cm <sup>4</sup>
$W_{x,y}$	=	1.75 cm <sup>3</sup>
Cross section area	=	2.95 cm <sup>2</sup>
Weight	=	0.8 kg/m

#### Order data Order number

30x30 corner extrusion	
Standard length 5000 mm	B02-3-00/5000
30x30 corner extrusion	
Cut to length	B02-3-02-02/...
Extra machining	Pages 34/35



#### Technical data

$I_{x,y}$	=	2.70 cm <sup>4</sup>
$W_{x,y}$	=	1.75 cm <sup>3</sup>
Cross section area	=	2.98 cm <sup>2</sup>
Weight	=	0.8 kg/m

#### Order data Order number

30x30 corner enclosure extrusion	
Standard length 5000 mm	B01-3-00/5000
30x30 corner enclosure extrusion	
Cut to length	B01-3-02-02/...
Extra machining	Pages 34/35

### 30x30 double face extrusion type B02-4

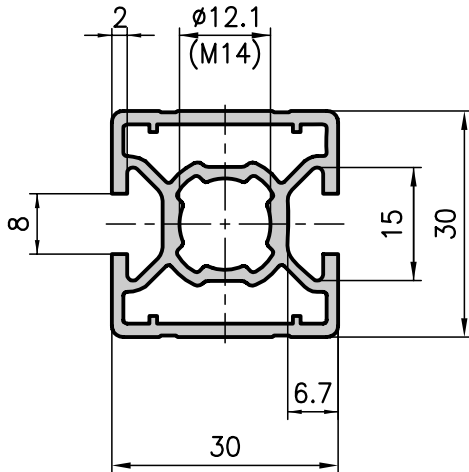

#### Application

For all types of enclosure, as well as for structures with extrusion faces which are mainly closed and for applications with an attractive design

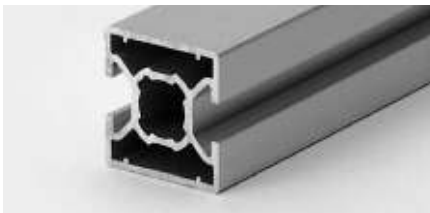

#### Technical data

$I_x$	=	2.73 cm <sup>4</sup>
$I_y$	=	2.74 cm <sup>4</sup>
$W_x$	=	1.82 cm <sup>3</sup>
$W_y$	=	1.83 cm <sup>3</sup>
Cross section area	=	2.91 cm <sup>2</sup>
Weight	=	0.8 kg/m

#### Order data      Order number

30x30 double face extrusion	
Standard length 5000 mm	B02-4-00/5000
30x30 double face extrusion	
Cut to length	B02-4-02-02/...
Extra machining	Pages 34/35

### 30x30 softline extrusion type B01-8

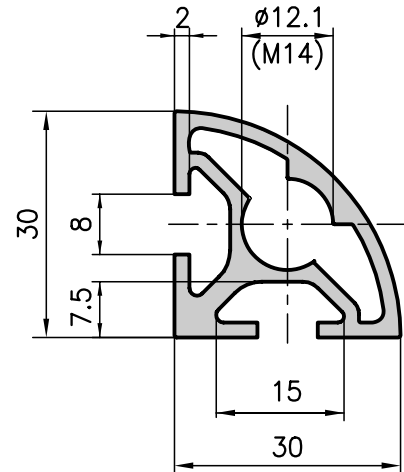

#### Application

This extrusion is used to build furniture, display cases and other objects without obtrusive sharp edges.



#### Technical data

$I_{x,y}$	=	2.57 cm <sup>4</sup>
$W_{x,y}$	=	2.02 cm <sup>3</sup>
Cross section area	=	2.91 cm <sup>2</sup>
Weight	=	0.8 kg/m

#### Order data      Order number

30x30 softline extrusion	
Standard length 5000 mm	B01-8-00/5000
30x30 softline extrusion	
Cut to length	B01-8-02-02/...
Extra machining	Pages 34/35

## Corner extrusion 30° type B04-3

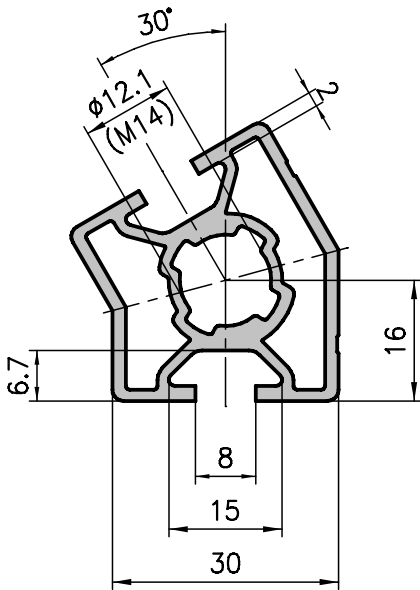

## Corner extrusion 45° type B04-4

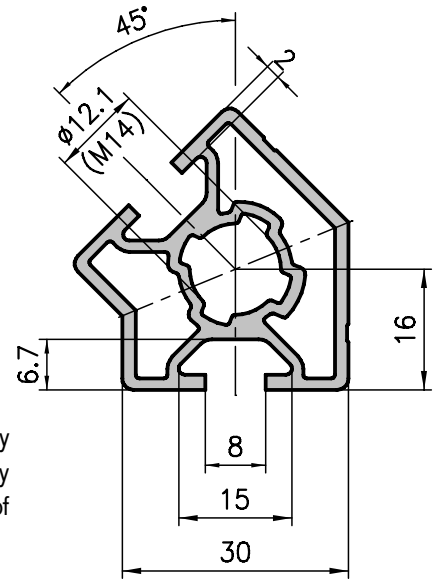

### Application

For stands, tables, safety guards or display cabinets with sloping surfaces or for any angled construction. This group of extrusions ensures elegant shapes.



### Technical Data

$I_x$	=	3.23 cm <sup>4</sup>
$I_y$	=	2.89 cm <sup>4</sup>
$W_x$	=	1.54 cm <sup>3</sup>
$W_y$	=	1.48 cm <sup>3</sup>
Cross section area	=	3.13 cm <sup>2</sup>
Weight	=	0.9 kg/m

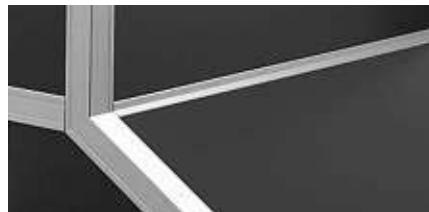

### Technical Data

$I_x$	=	3.14 cm <sup>4</sup>
$I_y$	=	2.91 cm <sup>4</sup>
$W_x$	=	1.44 cm <sup>3</sup>
$W_y$	=	1.45 cm <sup>3</sup>
Cross section area	=	3.13 cm <sup>2</sup>
Weight	=	0.9 kg/m

### Order data

Corner extrusion 45°	
Standard length 5000 mm	B04-4-00/5000
Corner extrusion 45°	
Cut to length	B04-4-02-02/...
Extra machining	Pages 34/35

### Order data

Corner extrusion 30°	
Standard length 5000 mm	B04-3-00/5000
Corner extrusion 30°	
Cut to length	B04-3-02-02/...
Extra machining	Pages 34/35

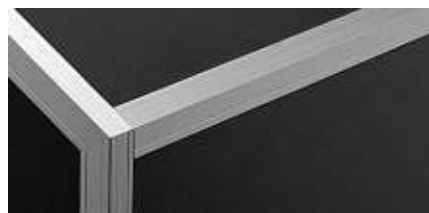

## Corner extrusion 60° type B04-6

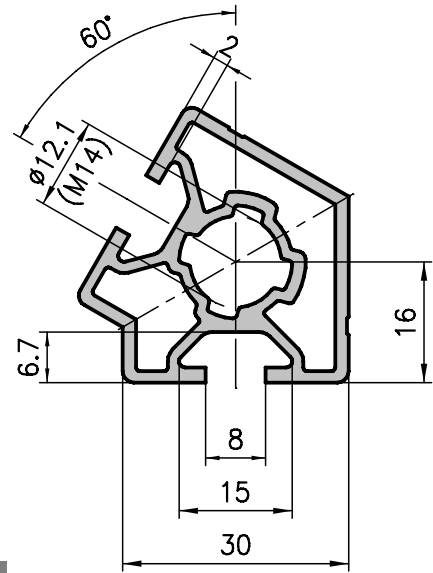

### Technical Data

$I_x$	=	3.14 cm <sup>4</sup>
$I_y$	=	2.91 cm <sup>4</sup>
$W_x$	=	1.44 cm <sup>3</sup>
$W_y$	=	1.45 cm <sup>3</sup>
Cross section area	=	3.04 cm <sup>2</sup>
Weight	=	0.9 kg/m

### Order data

### Order number

Corner extrusion 60° Standard length 5000 mm	B04-6-00/5000
Corner extrusion 60° Cut to length	B04-6-02-02/...
Extra machining	Pages 34/35

### 30x50 base extrusion type B01-9

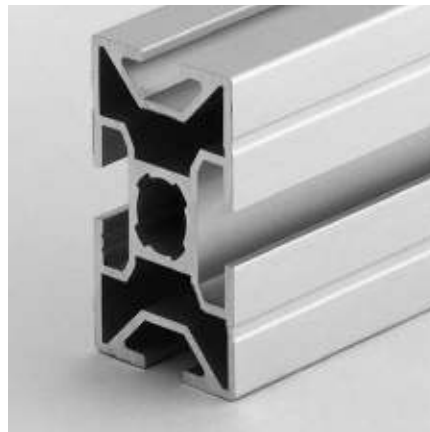
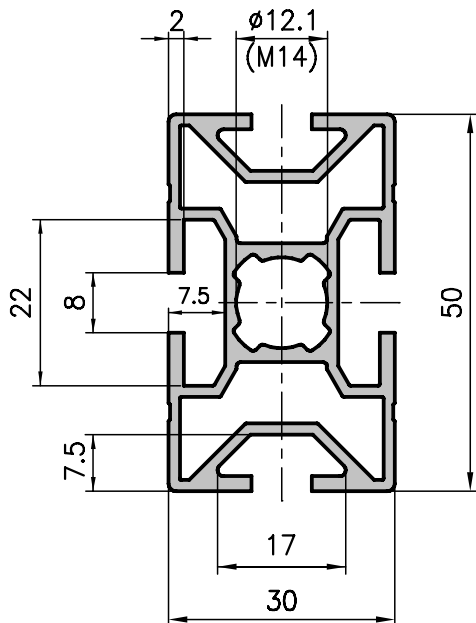

#### Application

Used for all types of structures, base frames, trolleys, conveyor belts, etc. Versatile and easy to use in conjunction with extrusions with bases of 30, 40 or 50 mm. This extrusion is sturdy and strong, despite using little aluminium.

### 30x50 face extrusion type MB2-9

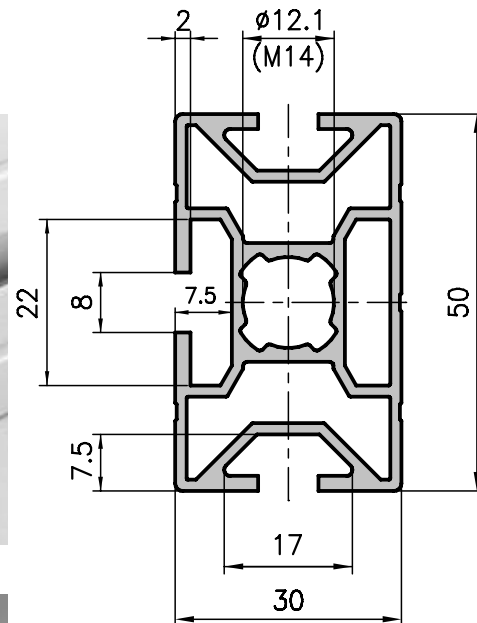

#### Application

Ideal for any application which requires an attractive design and structural stability. This is another versatile extrusion which can be used for tackling a wide range of different problems.

#### Technical data

Ix	=	10.94 cm <sup>4</sup>
Iy	=	4.33 cm <sup>4</sup>
Wx	=	4.38 cm <sup>3</sup>
Wy	=	2.90 cm <sup>3</sup>
Cross section area	=	4.34 cm <sup>2</sup>
Weight	=	1.2 kg/m

#### Order data Order number

30x50 base extrusion	
Standard length 5000 mm	B01-9-00/5000
30x50 base extrusion	
Cut to length	B01-9-02-02/...
Extra machining	Pages 34/35

#### Technical data

Ix	=	11.30 cm <sup>4</sup>
Iy	=	4.55 cm <sup>4</sup>
Wx	=	4.52 cm <sup>3</sup>
Wy	=	3.03 cm <sup>3</sup>
Cross section area	=	4.52 cm <sup>2</sup>
Weight	=	1.3 kg/m

#### Order data Order number

30x50 face extrusion	
Standard length 5000 mm	MB2-9-00/5000
30x50 face extrusion	
Cut to length	MB2-9-02-02/...
Extra machining	Pages 34/35



### 30x50 face extrusion with panel slots type MB1-9

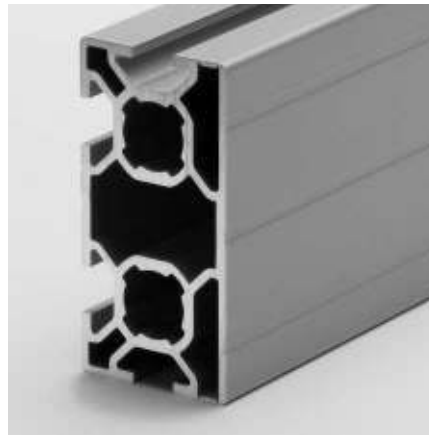
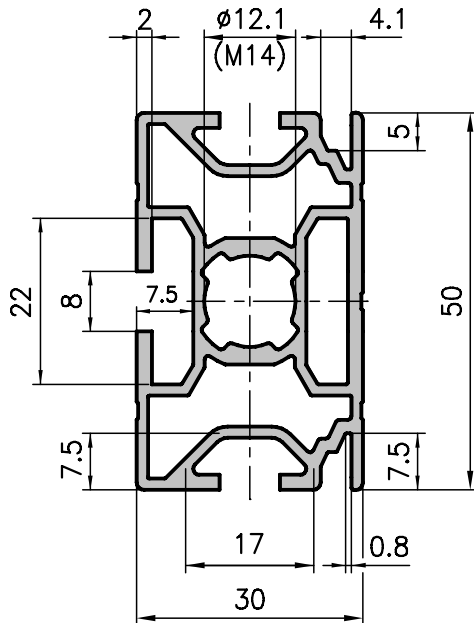

#### Application

The narrow slots hold panels measuring up to 4 mm in thickness securely and firmly in place. Therefore, this extrusion is ideal in any application where covers and cladding of various types are being fitted.

#### Technical data

$I_x$	=	11.25 cm <sup>4</sup>
$I_y$	=	4.84 cm <sup>4</sup>
$W_x$	=	4.50 cm <sup>3</sup>
$W_y$	=	3.23 cm <sup>3</sup>
Cross section area	=	5.00 cm <sup>2</sup>
Weight	=	1.3 kg/m

#### Order data      Order number

30x50 face enclosure extrusion	
Standard length 5000 mm	MB1-9-00/5000
30x50 face enclosure extrusion	
Cut to length	MB1-9-02-02/...
Extra machining	Pages 34/35

### 30x60 face extrusion with panel slots type B03-6

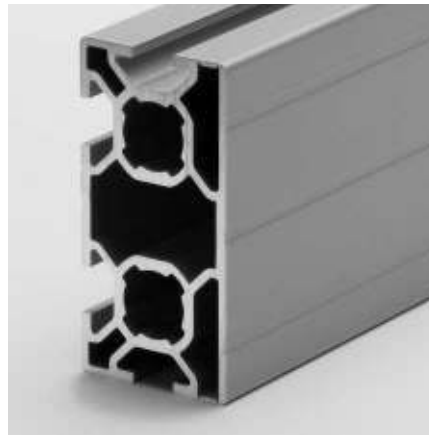
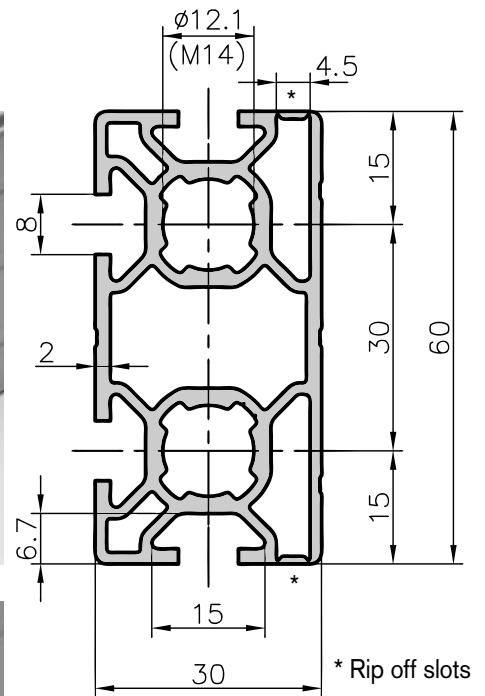

#### Application

With the same function as the extrusion type MB1-9 but with the difference being that the small slots have to be opened if they are required.

#### Technical data

$I_x$	=	19.33 cm <sup>4</sup>
$I_y$	=	5.43 cm <sup>4</sup>
$W_x$	=	6.44 cm <sup>3</sup>
$W_y$	=	3.60 cm <sup>3</sup>
Cross section area	=	5.48 cm <sup>2</sup>
Weight	=	1.5 kg/m

#### Order data      Order number

30x60 face extrusion with panel slots	
Standard length 5000 mm	B03-6-00/5000
30x60 face extrusion with panel slots	
Cut to length	B03-6-02-02/...
Extra machining	Pages 34/35

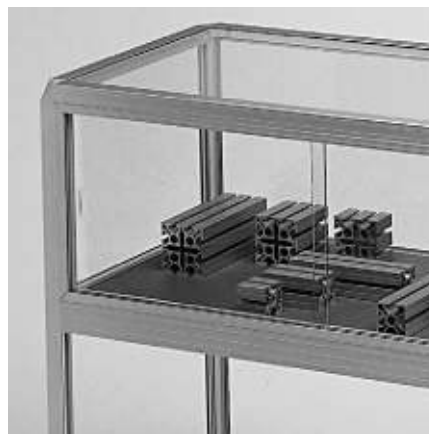

### 30x60 base extrusion type B01-6

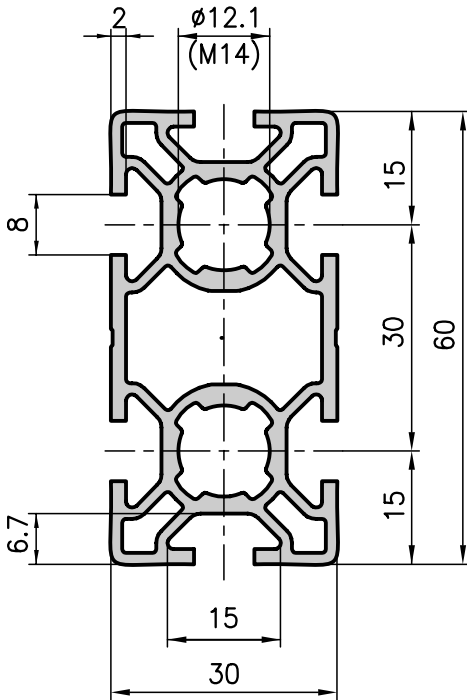

### Base extrusion 60x60 type B02-6

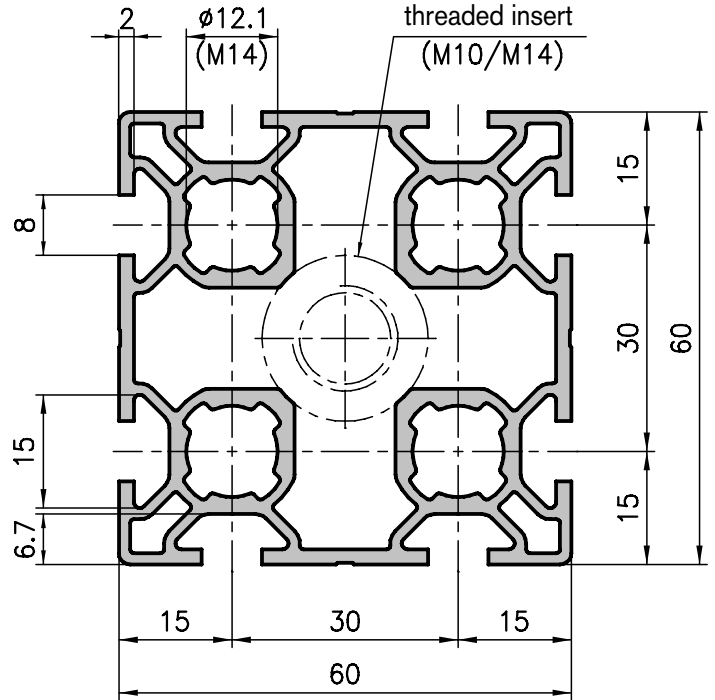

#### Application

Ideally suited for use as a cross-beam or for building lightweight conveyor belts. A versatile extrusion for many applications.

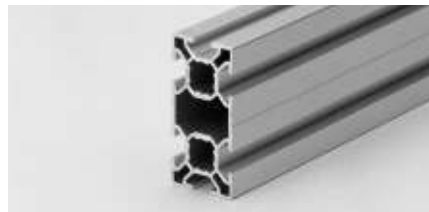

#### Application

Mainly used as a brace. Levelling feet and castors can be attached using the threaded inserts B33-60 or B33-64.

#### Technical data

$I_x$	=	20.52 cm <sup>4</sup>
$I_y$	=	5.20 cm <sup>4</sup>
$W_x$	=	6.84 cm <sup>3</sup>
$W_y$	=	3.47 cm <sup>3</sup>
Cross section area	=	5.47 cm <sup>2</sup>
Weight	=	1.5 kg/m

#### Order data Order number

30x60 base extrusion	
Standard length 5000 mm	B01-6-00/5000
30x60 base extrusion	
Cut to length	B01-6-02-02/...
Extra machining	Pages 34/35



#### Technical data

$I_{x,y}$	=	35.83 cm <sup>4</sup>
$W_{x,y}$	=	11.94 cm <sup>3</sup>
Cross section area	=	9.04 cm <sup>2</sup>
Weight	=	2.4 kg/m

#### Order data Order number

Base extrusion 60x60	
Standard length 5000 mm	B02-6-00/5000
Base extrusion 60x60	
Cut to length	B02-6-02-02/...
Insert M10	B33-60
Insert M14	B33-64
Extra machining	Pages 34/35

## 30 mm base octagonal extrusion type B15-3

### Application

Ideal for large, heavy duty machine enclosures in a round design, and as an axial extrusion for rotating structures. It can also have base plates bolted on and be used as a support extrusion. An elegant extrusion for interior decoration such as tables, carriages, etc.

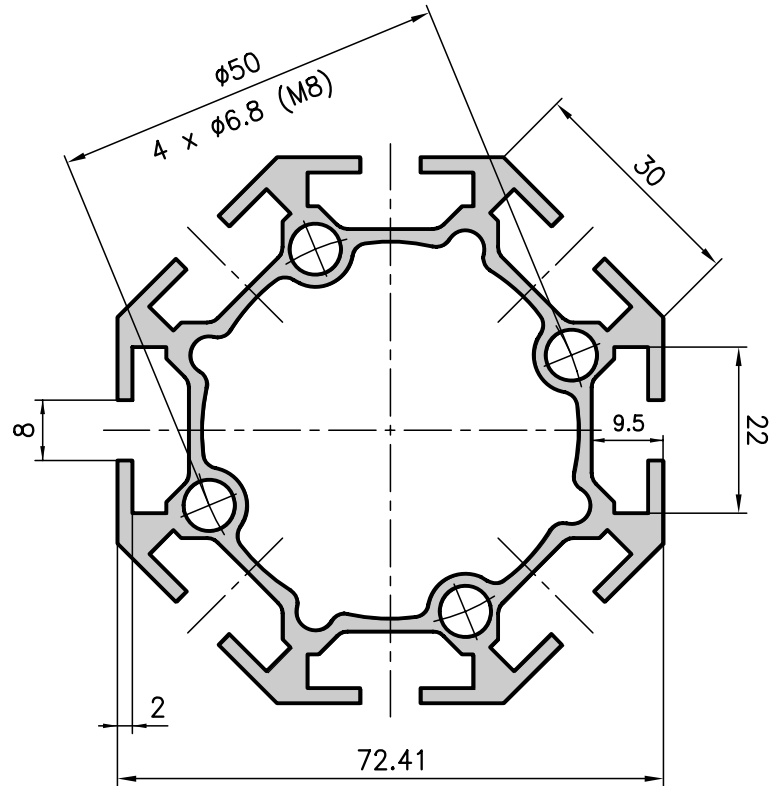
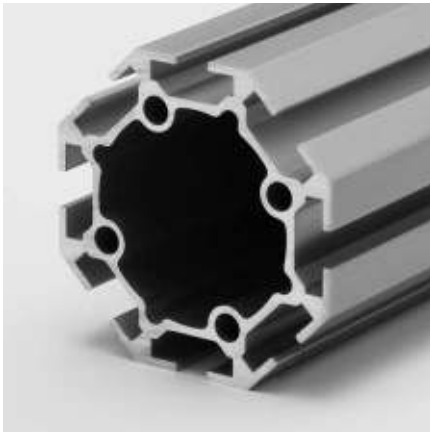

### Technical data

$I_{x,y}$	=	51.01 cm <sup>4</sup>
$W_{x,y}$	=	14.09 cm <sup>3</sup>
Cross section area	=	10.30 cm <sup>2</sup>
Weight	=	2.8 kg/m

### Order data      Order number

30 mm base octagonal extrusion	
Standard length 5000 mm	B15-3-00/5000
30 mm base octagonal extrusion	
Cut to length	B15-3-02-02/...
Extra machining	Pages 34/35



### 30x100 base extrusion type MB1-2

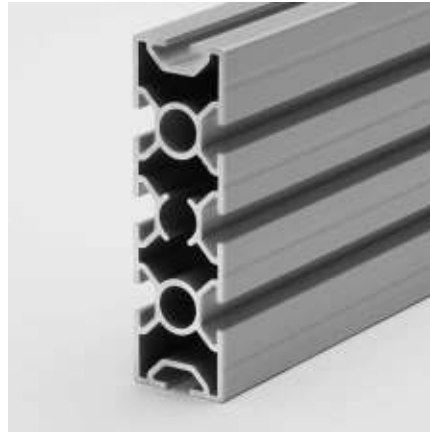
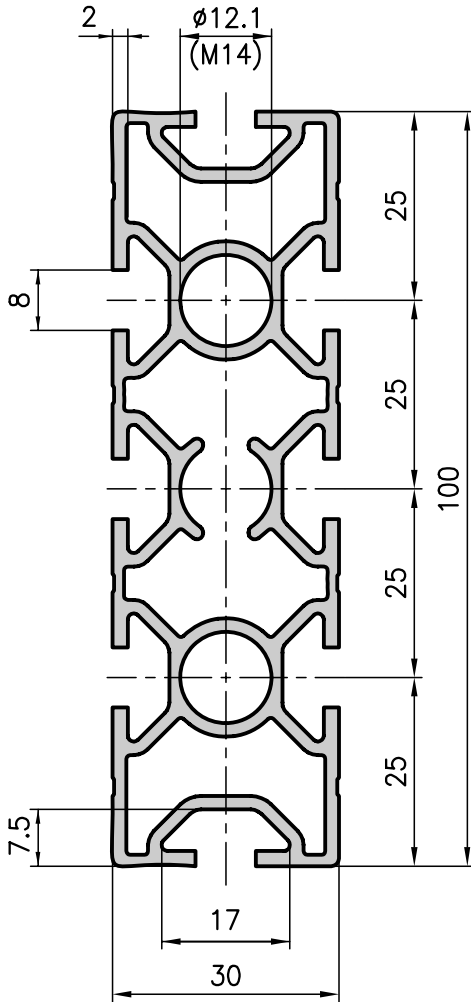

#### Application

For cross-beams on base frames, conveyor belts, trolleys or for large areas of panelling. This versatile extrusion can also be used in combination with extrusions with a base of 40 or 50 mm. A lightweight, sturdy extrusion which can be connected in many different configurations.

### 30x100 face extrusion with panel slots type B01-2

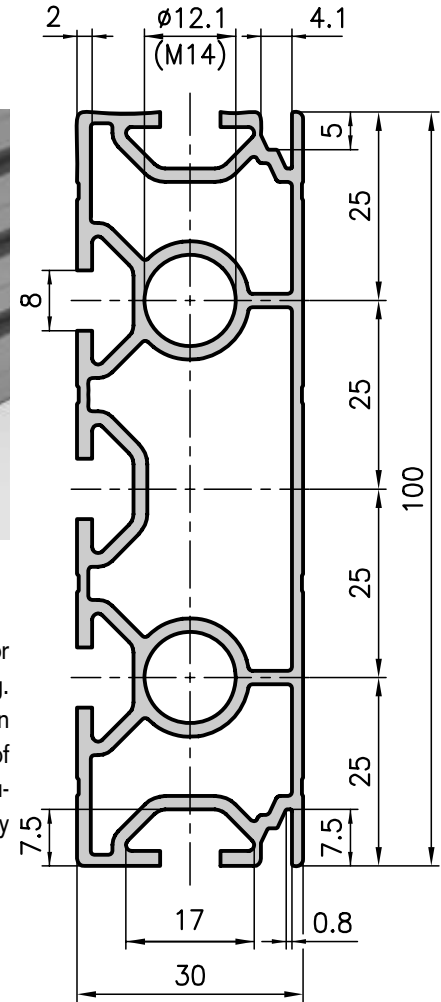

#### Technical data

Ix	=	77.86 cm <sup>4</sup>
Iy	=	8.79 cm <sup>4</sup>
Wx	=	15.57 cm <sup>3</sup>
Wy	=	5.72 cm <sup>3</sup>
Cross section area	=	7.72 cm <sup>2</sup>
Weight	=	2.1 kg/m

#### Order data Order number

30x100 face enclosure extrusion	
Standard length 5000 mm	B01-2-00/5000
30x100 face enclosure extrusion	
auf Länge zugeschnitten	B01-2-02-02/...
Extra machining	Pages 34/35

#### Technical data

Ix	=	80.77 cm <sup>4</sup>
Iy	=	8.95 cm <sup>4</sup>
Wx	=	16.15 cm <sup>3</sup>
Wy	=	5.97 cm <sup>3</sup>
Cross section area	=	8.59 cm <sup>2</sup>
Weight	=	2.3 kg/m

#### Order data Order number

30x100 base extrusion	
Standard length 5000 mm	MB1-2-00/5000
30x100 base extrusion	
auf Länge zugeschnitten	MB1-2-02-02/...
Extra machining	Pages 34/35

## 30x300 face extrusion type B03-3

### Application

Positioned on its edge, this extrusion can be used as a cross-beam to support heavy loads. However, it can also be used as a bed plate or as a superior panel.



### Technical data

$I_x$	= 1755.64 cm <sup>4</sup>
$I_y$	= 26.06 cm <sup>4</sup>
$W_x$	= 117.04 cm <sup>3</sup>
$W_y$	= 17.30 cm <sup>3</sup>
Cross section area	= 18.74 cm <sup>2</sup>
Weight	= 5.10 kg/m

### Order data

### Order number

30x300 face extrusion	
Standard length 5000 mm	B03-3-00/5000
30x300 face extrusion	
Cut to length	B03-3-02-02/...
Extra machining	Pages 34/35

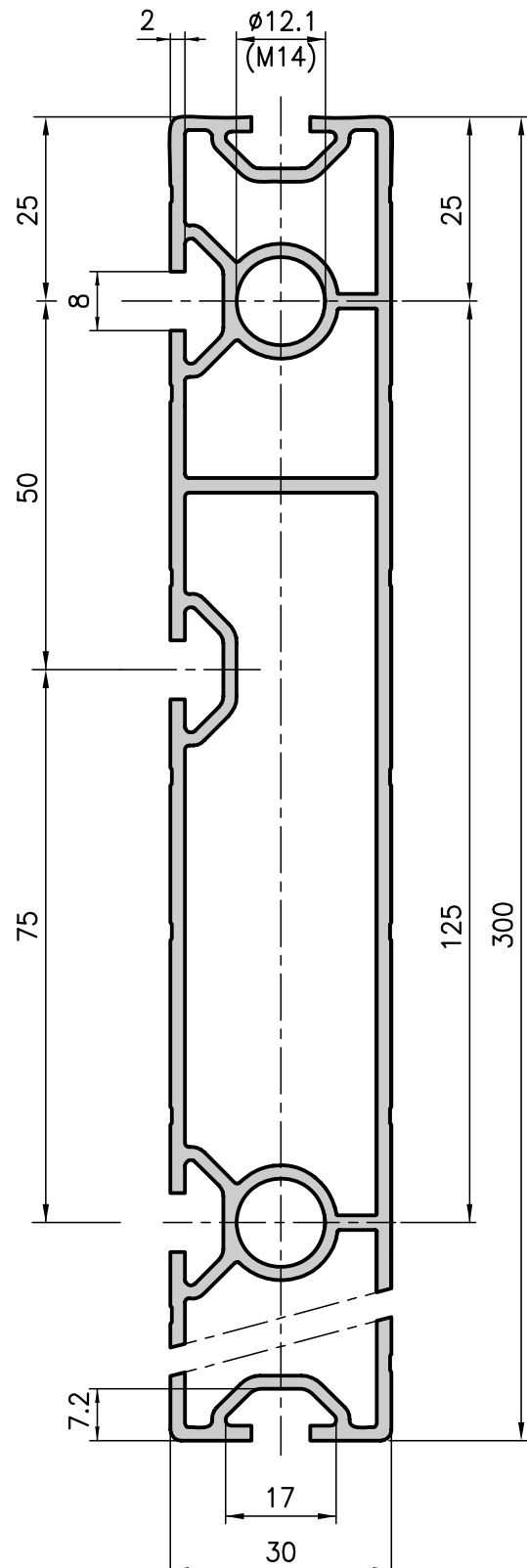

### 20x20 base extrusion type D01-5

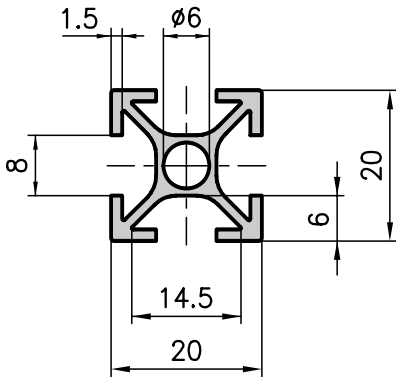

### 20x20 corner extrusion type D01-3

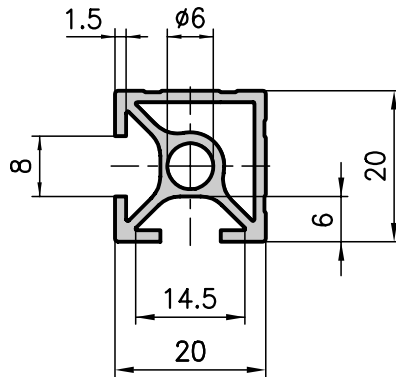

### 20x20 face extrusion type D01-8

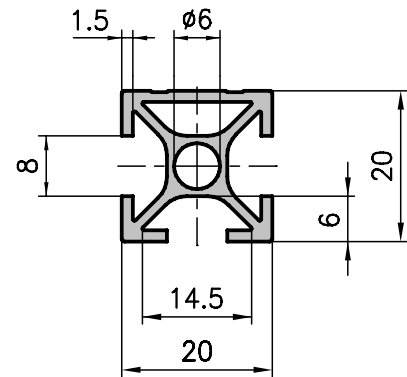

#### Application

Due to their relatively low weight and strength this 20x20/40 range of extrusions can only be used for small loads, such as limit switches fixtures, smart work frames, small display cases, etc.

Helicoil inserts (DIN 8140) can be used for all extrusions with a core hole of Ø6  
See machining code H3/H4.

The 20x20 and 20x40 extrusions are also suitable as a support or reinforcement extrusion behind panels, which is in combination with the base 30 extrusion with panel slots (see sketch).

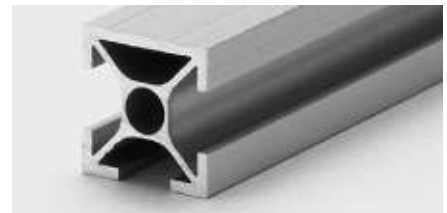
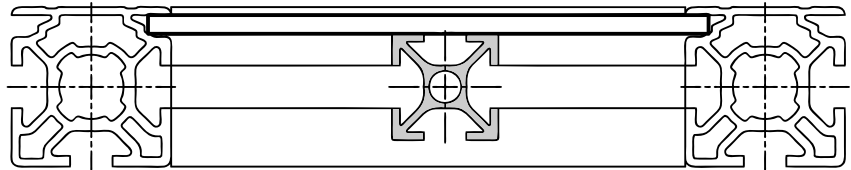

#### Technical data

$I_{x,y}$	=	0.60 cm <sup>4</sup>
$W_{x,y}$	=	0.60 cm <sup>3</sup>
Cross section area	=	1.40 cm <sup>2</sup>
Weight	=	0.38 kg/m

#### Technical data

$I_{x,y}$	=	0.65 cm <sup>4</sup>
$W_{x,y}$	=	0.65 cm <sup>3</sup>
Cross section area	=	1.54 cm <sup>2</sup>
Weight	=	0.42 kg/m

#### Technical data

$I_x$	=	0.68 cm <sup>4</sup>
$I_y$	=	0.59 cm <sup>4</sup>
$W_x$	=	0.68 cm <sup>3</sup>
$W_y$	=	0.59 cm <sup>3</sup>
Cross section area	=	1.46 cm <sup>2</sup>
Weight	=	0.39 kg/m

#### Order data

#### Order number

20x20 base extrusion	
Standard length 5000 mm	D01-5-00/5000
20x20 base extrusion	
Cut to length	D01-5-02-02/...
Extra machining	Pages 34/35

#### Order data

#### Order number

20x20 corner extrusion	
Standard length 5000 mm	D01-3-00/5000
20x20 corner extrusion	
Cut to length	D01-3-02-02/...
Extra machining	Pages 34/35

#### Order data

#### Order number

20x20 face extrusion	
Standard length 5000 mm	D01-8-00/5000
20x20 face extrusion	
Cut to length	D01-8-02-02/...
Extra machining	Pages 34/35

### 20x20 Softline extrusion type D03-8

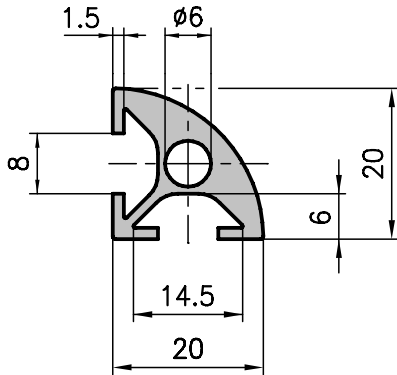

### 20x40 base extrusion type D01-7

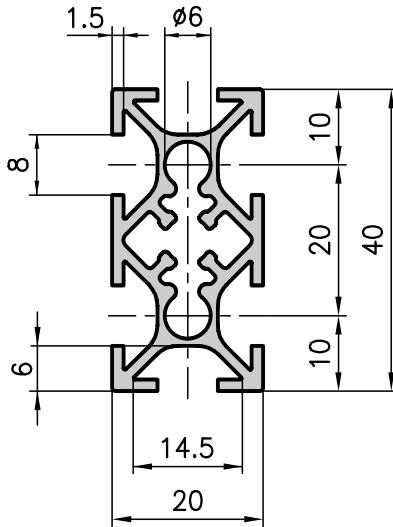

### 20x40 face extrusion type D02-8

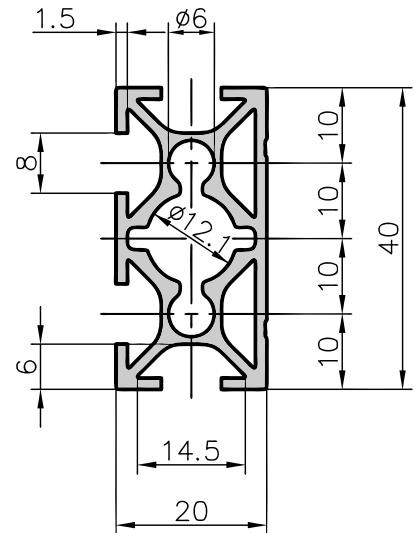

#### Application

For small picture frames as well as for decorative application.



#### Application

A multi purpose extrusion, which is easily compatible with the base 40. The center hole is Ø12.1 so that the bigger connectors can also be used, making application possibilities even more versatile.

#### Technical data

$I_x, y$	=	0.47 cm <sup>4</sup>
$W_{x, y}$	=	0.47 cm <sup>3</sup>
Cross section area	=	1.29 cm <sup>2</sup>
Weight	=	0.35 kg/m

#### Technical data

$I_x$	=	3.91 cm <sup>4</sup>
$I_y$	=	1.10 cm <sup>4</sup>
$W_x$	=	1.95 cm <sup>3</sup>
$W_y$	=	1.10 cm <sup>3</sup>
Cross section area	=	2.69 cm <sup>2</sup>
Weight	=	0.73 kg/m

#### Technical data

$I_x$	=	4.15 cm <sup>4</sup>
$I_y$	=	1.26 cm <sup>4</sup>
$W_x$	=	2.07 cm <sup>3</sup>
$W_y$	=	1.18 cm <sup>3</sup>
Cross section area	=	2.79 cm <sup>2</sup>
Weight	=	0.75 kg/m

#### Order data

#### Order number

Softline extrusion	
Standard length 5000 mm	D03-8-00/5000
Softline extrusion	
Cut to length	D03-8-02-02/...
Extra machining	Pages 34/35

#### Order data

#### Order number

20x40 base extrusion	
Standard length 5000 mm	D01-7-00/5000
20x40 base extrusion	
Cut to length	D01-7-02-02/...
Extra machining	Pages 34/35

#### Order data

#### Order number

20x40 face extrusion	
Standard length 5000 mm	D02-8-00/5000
20x40 face extrusion	
Cut to length	D02-8-02-02/...
Extra machining	Pages 34/35

## 20 mm base octagonal extrusion type D01-1

## 20x40 box frame extrusion type D01-6

## 20x47 box frame extrusion type D01-2

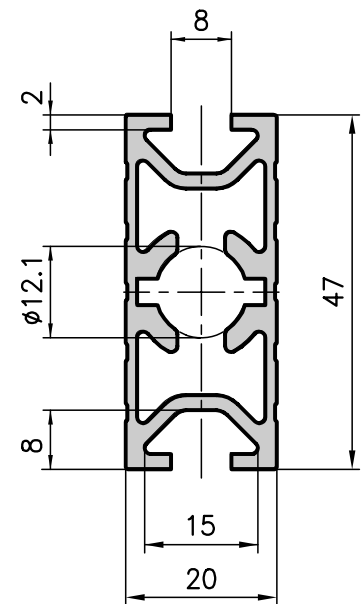
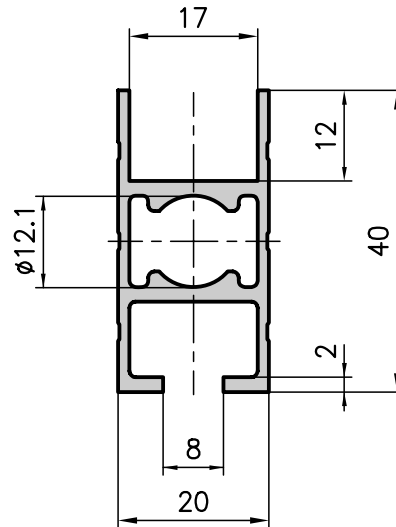
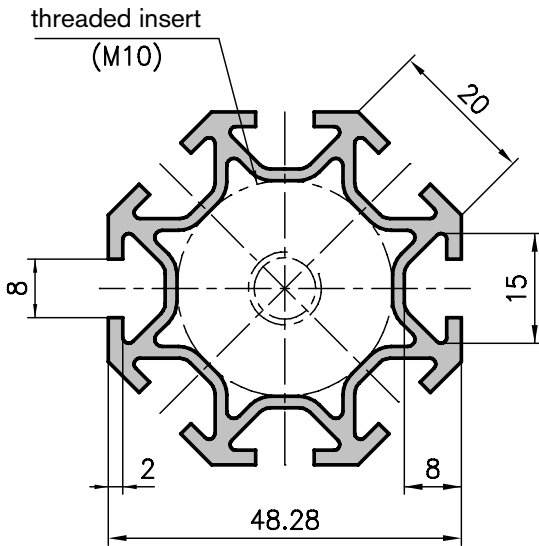

### Application

For light, octagonal machine protection guards, as axle extrusions for rotating constructions as well as for pillars. An M10 insert can be pressed into the cross section, order number D33-10, which is designed for screwing in a leveling foot.

### Application

Developed specially for the construction of exhibition stands. Designed to hold 16 mm particle board panels at one end and 6/8 mm panels at the other end.

### Application

This extrusion is generally used in combination with the octagonal D01-1 extrusion, so can also be used in the exhibition stand construction.



### Technical data

$I_{x,y}$	=	9.96 cm <sup>4</sup>
$W_{x,y}$	=	4.13 cm <sup>3</sup>
Cross section area	=	4.75 cm <sup>2</sup>
Weight	=	1.31 kg/m

### Order data

### Order number

20 mm base octagonal extrusion	
Standard length 5000 mm	D01-1-00/5000
20 mm base octagonal extrusion	
Cut to length	D01-1-02-02/...
M10 threaded insert	D33-10
Extra machining	Pages 34/35

### Technical data

$I_x$	=	2.60 cm <sup>4</sup>
$I_y$	=	1.38 cm <sup>4</sup>
$W_x$	=	1.21 cm <sup>3</sup>
$W_y$	=	1.38 cm <sup>3</sup>
Cross section area	=	2.39 cm <sup>2</sup>
Weight	=	0.7 kg/m

### Order data

### Order number

20x40 box frame extrusion	
Standard length 5000 mm	D01-6-00/5000
20x40 box frame extrusion	
Cut to length	D01-6-02-02/...
Extra machining	Pages 34/35

### Technical data

$I_x$	=	7.36 cm <sup>4</sup>
$I_y$	=	1.84 cm <sup>4</sup>
$W_x$	=	3.13 cm <sup>3</sup>
$W_y$	=	1.84 cm <sup>3</sup>
Cross section area	=	3.55 cm <sup>2</sup>
Weight	=	0.95 kg/m

### Order data

### Order number

20x47 box frame extrusion	
Standard length 5000 mm	D01-2-00/5000
20x47 box frame extrusion	
Cut to length	D01-2-02-02/...
Extra machining	Pages 34/35

## 20x95 box frame extrusion type D01-4

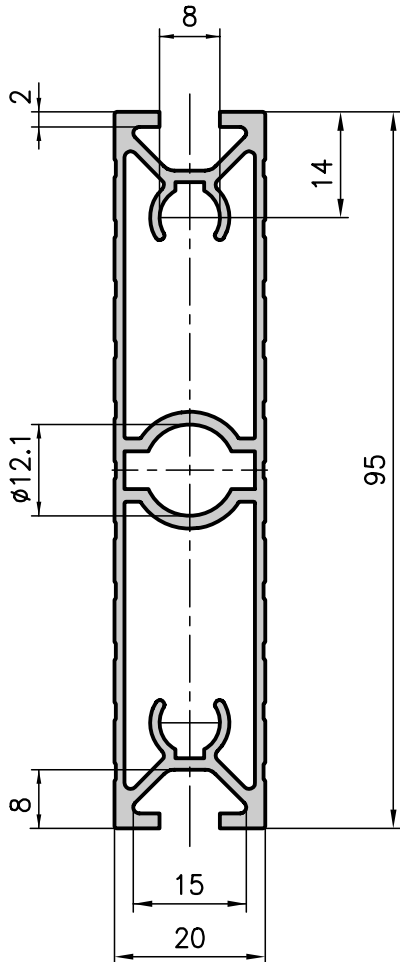

### Application

These extrusions which are lightweight yet very strong are used mainly in the construction of exhibition stands and shop fittings. They are also used in the construction of apparatus racks if closed extrusion faces are required. They can also be used as skirting boards along passages in order to stabilise walls and screens.

### Technical data

$I_x$	=	44.26 cm <sup>4</sup>
$I_y$	=	2.75 cm <sup>4</sup>
$W_x$	=	9.32 cm <sup>3</sup>
$W_y$	=	2.75 cm <sup>3</sup>
Cross section area	=	4.66 cm <sup>2</sup>
Weight	=	1.26 kg/m

### Order data

Order data	Order number
20x95 box frame extrusion Standard length 5850 mm	D01-4-00/5850
20x95 box frame extrusion Cut to length	D01-4-02-02/...
Extra machining	Pages 34/35

### Technical data

$I_x$	=	142.50 cm <sup>4</sup>
$I_y$	=	4.41 cm <sup>4</sup>
$W_x$	=	18.85 cm <sup>3</sup>
$W_y$	=	4.16 cm <sup>3</sup>
Cross section area	=	6.88 cm <sup>2</sup>
Weight	=	1.86 kg/m

### Order data

Order data	Order number
20x150 face extrusion Standard length 5000 mm	D19-5-00/5000
20x150 face extrusion Cut to length	D19-5-02-02/...
Extra machining	Pages 34/35

## 20x150 face extrusion type D19-5

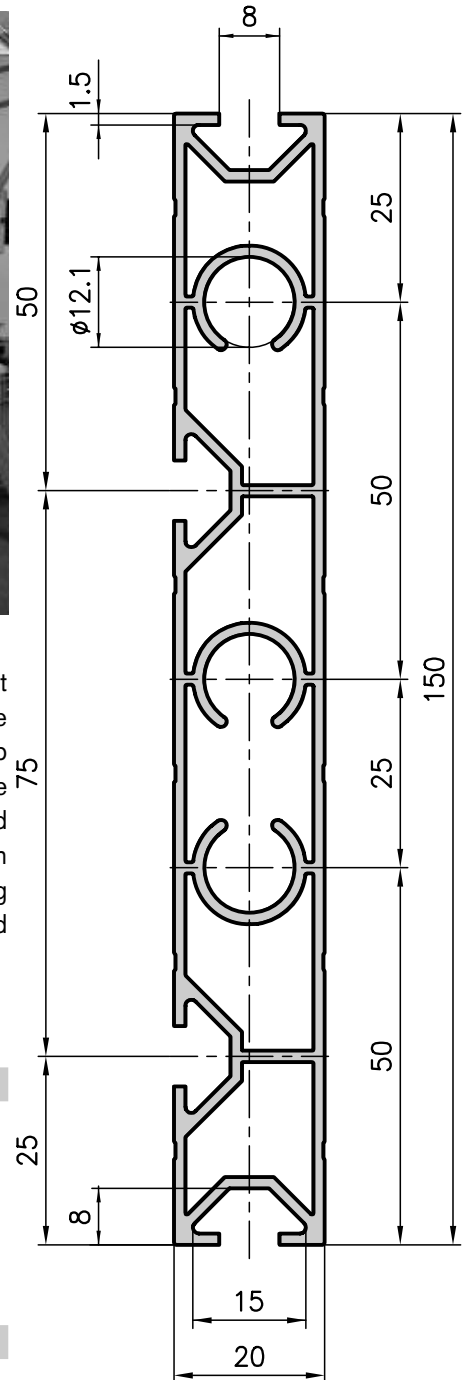

## 80x80 special extrusion type C01-2

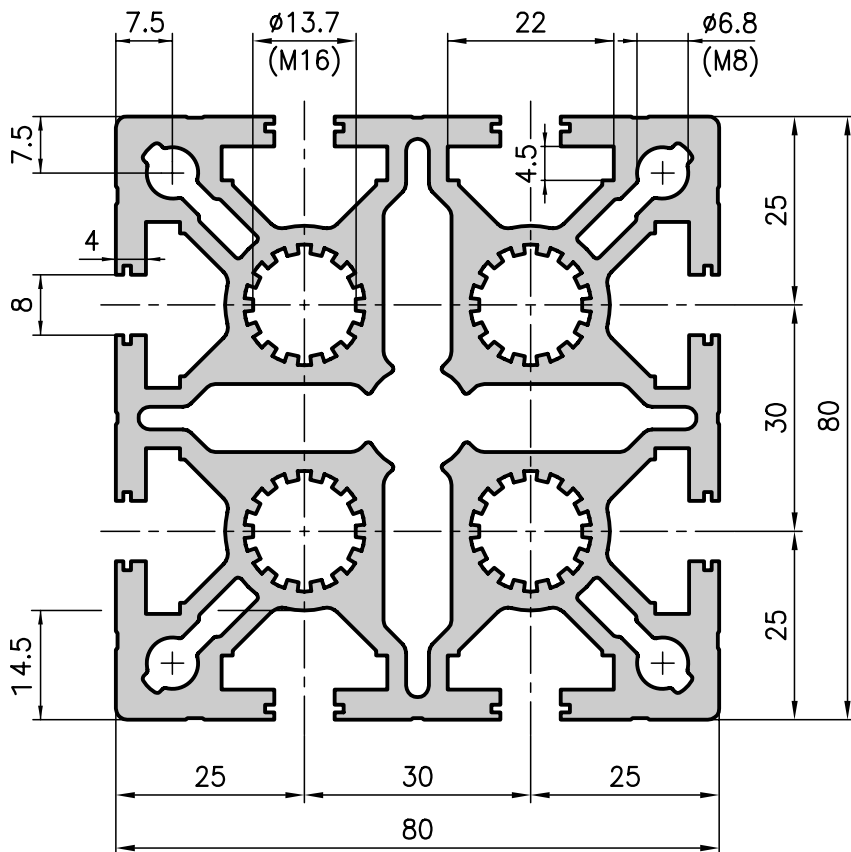

**Please note! The centreline inset (25mm) is based on the 50mm extrusion range.**

### Technical data

$I_{x,y}$	= 157.70 cm <sup>4</sup>
$W_{x,y}$	= 39.40 cm <sup>3</sup>
Cross section area	= 25.02 cm <sup>2</sup>
Weight	= 6.8 kg/m

### Order data

### Order number

80x80 special extrusion	
Standard length 5000 mm	C01-2-00/5000
80x80 special extrusion	
Cut to length	C01-2-02-02/...
Extra machining	Pages 34/35

### Application

This is a very special extrusion because the centreline inset (25 mm) is designed to fit extrusions with a **base of 50**. However, it also offers very obvious advantages when it is used in combination with extrusions with a base of 40 of securing enclosure panels in place. The panels can be attached directly to the frame structure without protruding out because they are set back 5 mm.



## 50x50 hand rail extrusion type A19-1

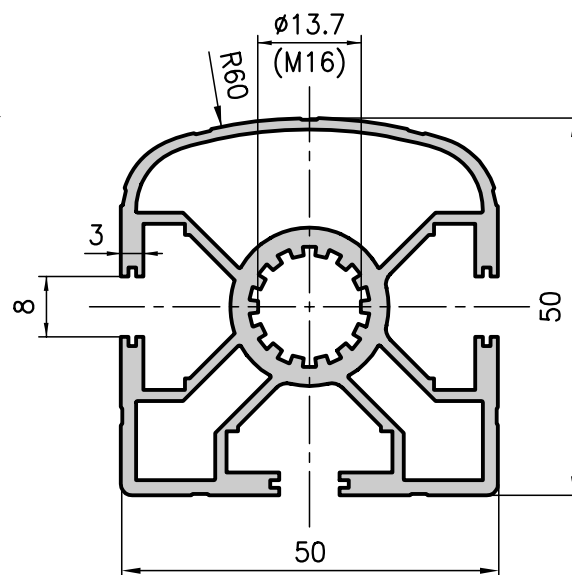

### Application

Hand rail extrusion for staircase railings or fence tops.

### Technical data

$I_x$	= 13.00 cm <sup>4</sup>
$I_y$	= 15.00 cm <sup>4</sup>
$W_x$	= 5.20 cm <sup>3</sup>
$W_y$	= 6.00 cm <sup>3</sup>
Cross section area	= 6.10 cm <sup>2</sup>
Weight	= 1.65 kg/m

### Order data

### Order number

50x50 hand rail extrusion	
Standard length 5000 mm	A19-1-00/5000
50x50 hand rail extrusion	
Cut to length	A19-1-02-02/...
Extra machining	Pages 34/35

## 20x80 slot extrusion type C08-2

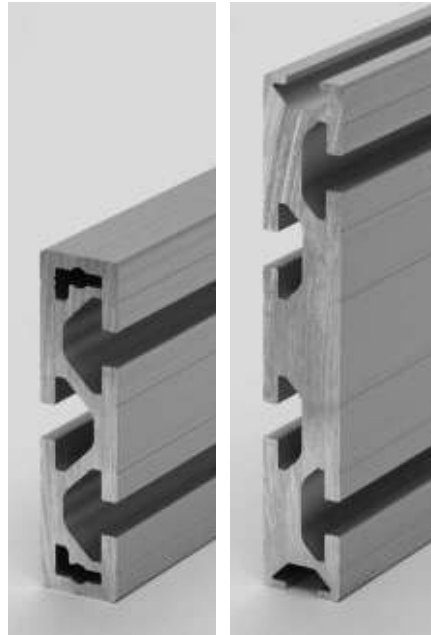
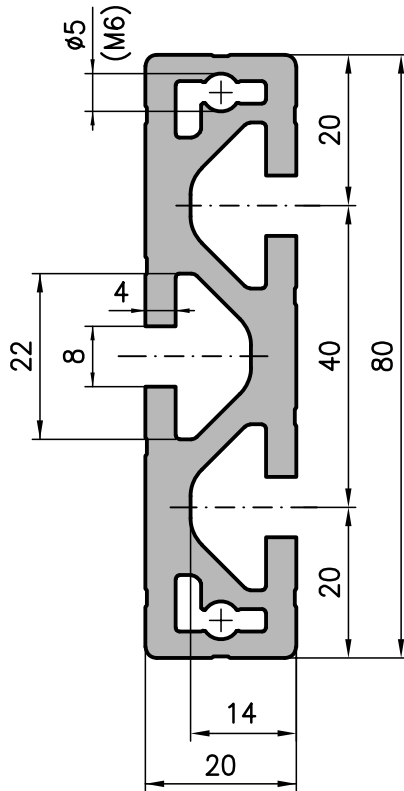

### Application

These slot extrusions are very versatile and can be used as a floor or adapter-plate, for heavy duty guidance, distance-holder as well as for fixing plates, etc.

### Technical data

$I_x$	=	54.49 cm <sup>4</sup>
$I_y$	=	3.97 cm <sup>4</sup>
$W_x$	=	13.62 cm <sup>3</sup>
$W_y$	=	3.97 cm <sup>3</sup>
Cross section area	=	8.90 cm <sup>2</sup>
Weight	=	2.4 kg/m

### Order data

### Order number

20x80 slot extrusion	
Standard length 5000 mm	C08-2-00/5000
20x80 slot extrusion	
Cut to length	C08-2-02-02/...

## 20x120 slot extrusion type C08-3

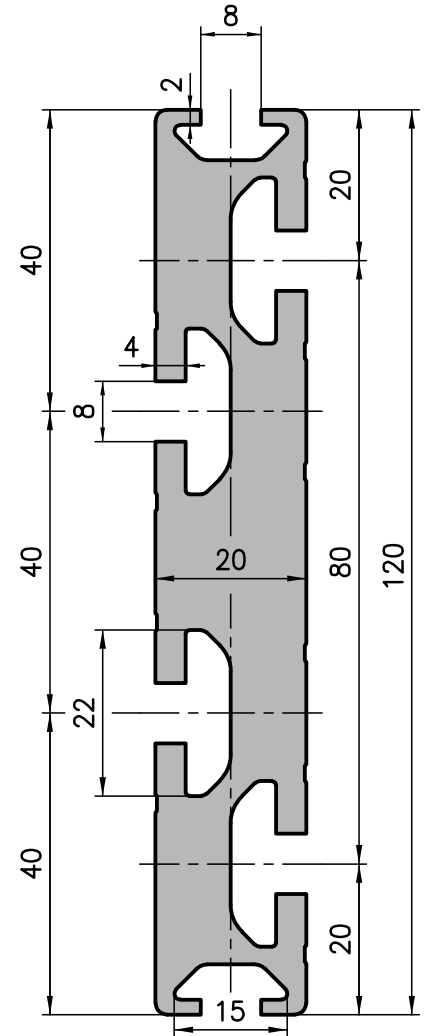

### Technical data

$I_x$	=	177.95 cm <sup>4</sup>
$I_y$	=	6.31 cm <sup>4</sup>
$W_x$	=	29.66 cm <sup>3</sup>
$W_y$	=	6.31 cm <sup>3</sup>
Cross section area	=	16.40 cm <sup>2</sup>
Weight	=	4.42 kg/m

### Order data

### Order number

20x120 slot extrusion	
Standard length 5000 mm	C08-3-00/5000
20x120 slot extrusion	
Cut to length	C08-3-02-02/...

## Wall rail 50x18 type A19-9

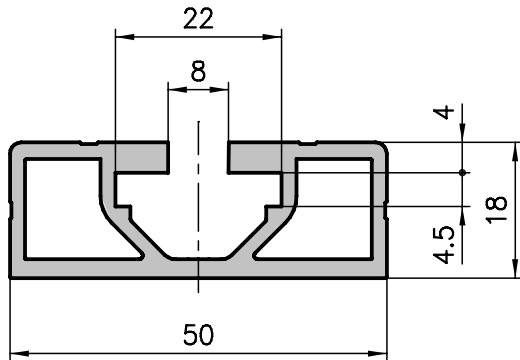

### Application

This is a very slim extrusion. When screwed to walls, it provides an easy method of fixing adjustable shelves.



### Technical data

Cross section area = 3.47 cm<sup>2</sup>  
Weight = 0.9 kg/m

### Order data

Order data	Order number
Wall rail	
Standard length 5000 mm	A019-9-00/5000
Wall rail	
Cut to length	A019-9-02-02/...

## 30x15 triple channel extrusion type B05-1

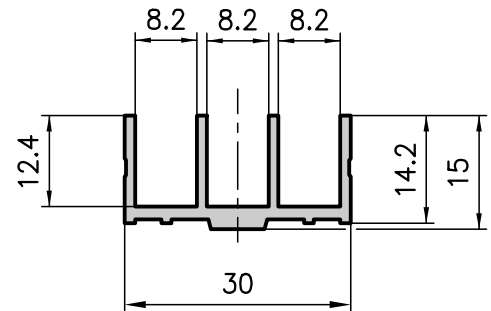

### Application

A screw-on extrusion which is ideal for inserting panels, glazing and sliding doors, or any application requiring an attractive finish with functional reliability. The triple channel extrusion can slide onto standard extrusions with the base 30 mm.

The plastic extrusions B39-55 and B39-35 can be used to improve the sliding properties, to reduce the size of the slots or as clip-on covers.

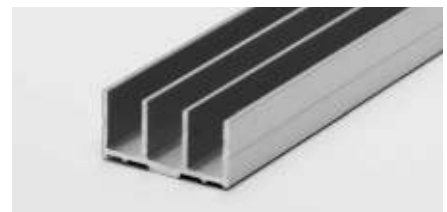
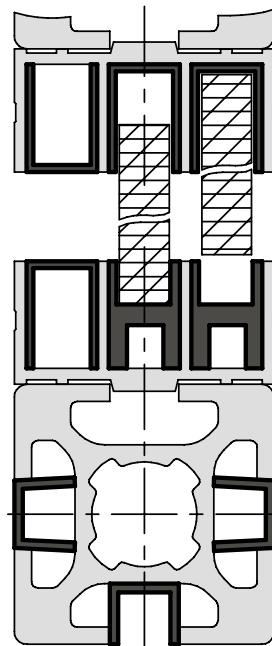

### Technical data

Cross section area = 1.18 cm<sup>2</sup>  
Weight = 0.32 kg/m

### Order data

Order data	Order number
30x15 triple channel extrusion	
Standard length 5000 mm	B05-1-00/5000
30x15 triple channel extrusion	
Cut to length	B05-1-02-02/...

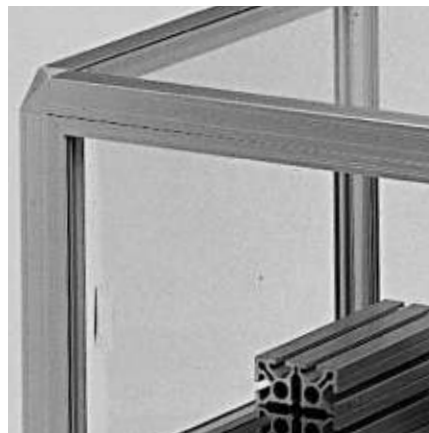

### 19" auxiliary extrusion type A05-2

### 19" auxiliary extrusion type B05-2

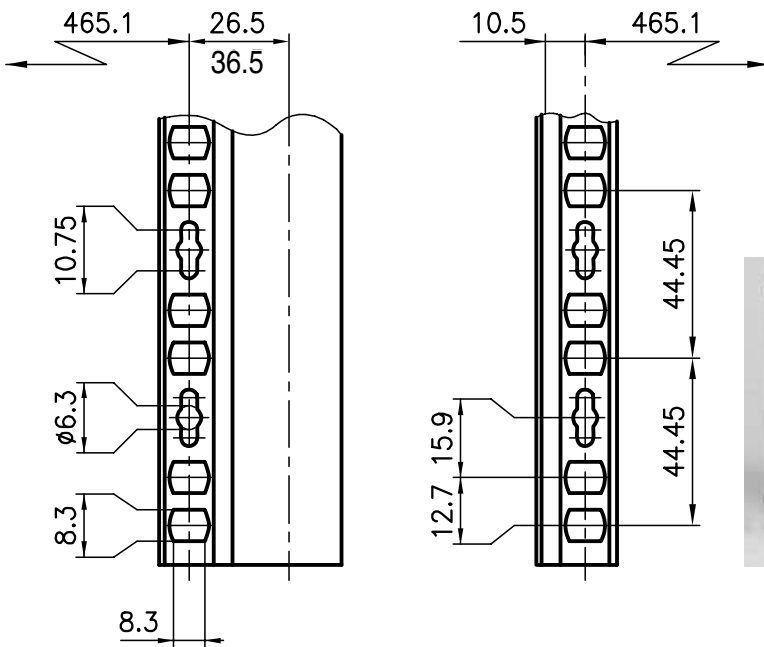
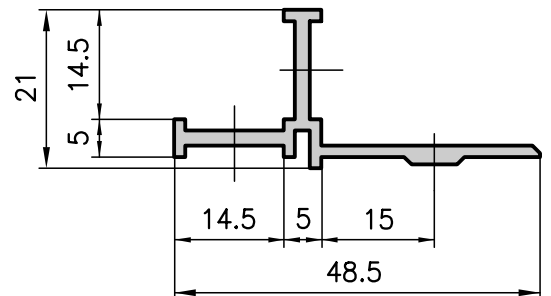
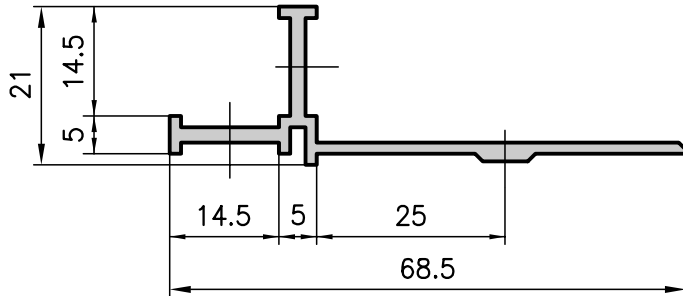

#### Application

The screw-on extrusion allows 19" racking to be incorporated into electronic, pneumatic and hydraulic applications. This specially punched rail can be bolted onto any standard design extrusion with a base of 50 or 30 mm. It meets the requirements of IEC297. Equipment is easy to install using M6 nuts and retaining clips.



#### Technical data

Cross section area = 1.67 cm<sup>2</sup>  
 Weight = 0.5 kg/m

#### Order data

#### Order number

19" auxiliary extrusion  
 Standard length 5000 mm A05-2-00/5000  
 19" auxiliary extrusion  
 Cut to length A05-2-02-02/...

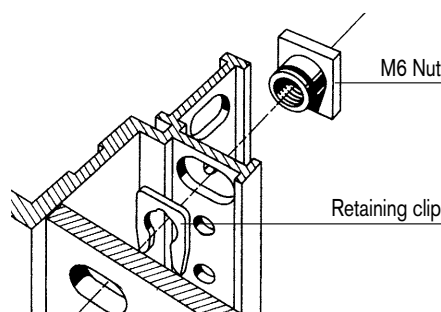

#### Order data

#### Order number

Retaining clip H2-506  
 Special M6 nut H2-504

#### Technical data

Cross section area = 1.37 cm<sup>2</sup>  
 Weight = 0.4 kg/m

#### Order data

#### Order number

19" auxiliary extrusion  
 Standard length 5000 mm B05-2-00/5000  
 19" auxiliary extrusion  
 Cut to length B05-2-02-02/...

### 30x30 base extrusion type B01-1

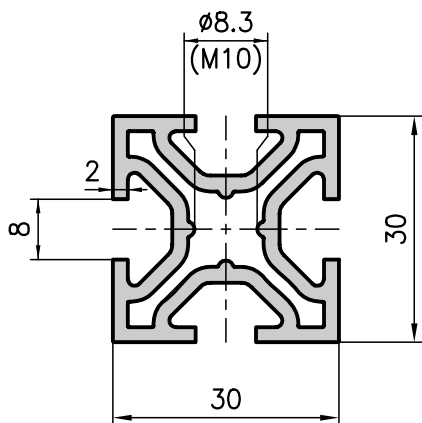

#### Application

These extrusions have been used successfully for years in the construction of exhibition booths and shop fittings. Thanks to their exceptional stability, they are used primarily as vertical support extrusions. One of their primary advantages is that the centre hole can be tapped directly for an M10 thread, for levelling feet and casters without needing any other accessory.

#### Technical data

$I_{x,y}$	=	3.37 cm <sup>4</sup>
$W_{x,y}$	=	2.22 cm <sup>3</sup>
Cross section area	=	3.71 cm <sup>2</sup>
Weight	=	1.0 kg/m

#### Order data Order number

30x30 base extrusion	
Standard length 5000 mm	B01-1-00/5000
30x30 base extrusion	
Cut to length	B01-1-02-02/...
Extra machining	Pages 34/35



#### Application

The box frame extrusion is used almost exclusively in exhibition stands and shop fittings. It is extremely sturdy and hardwearing.

### 30x95 box frame extrusion type B01-7

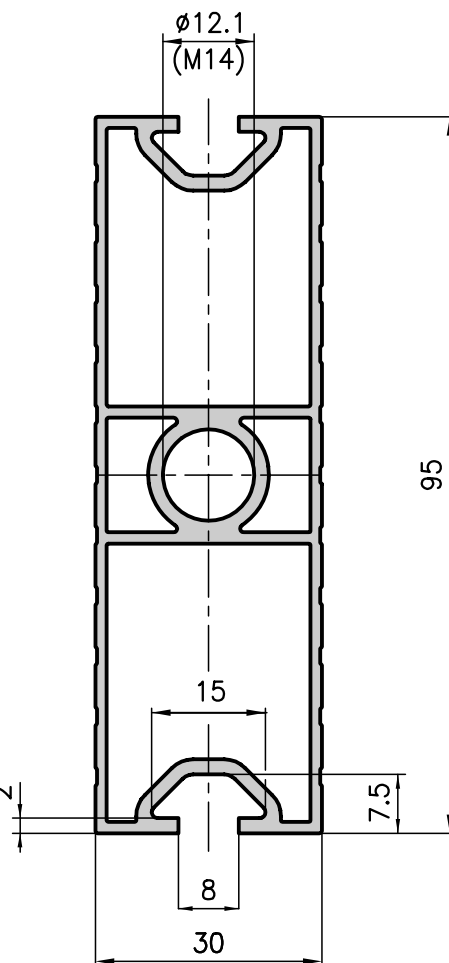

#### Technical data

$I_x$	=	55.99 cm <sup>4</sup>
$I_y$	=	7.94 cm <sup>4</sup>
$W_x$	=	11.79 cm <sup>3</sup>
$W_y$	=	5.29 cm <sup>3</sup>
Cross section area	=	6.54 cm <sup>2</sup>
Weight	=	1.8 kg/m

#### Order data Order number

30x95 box frame extrusion	
Standard length 5850 mm	B01-7-00/5850
30x95 box frame extrusion	
Cut to length	B01-7-02-02/...
Extra machining	Pages 34/35



### 30x30 runner extrusion type B10-3

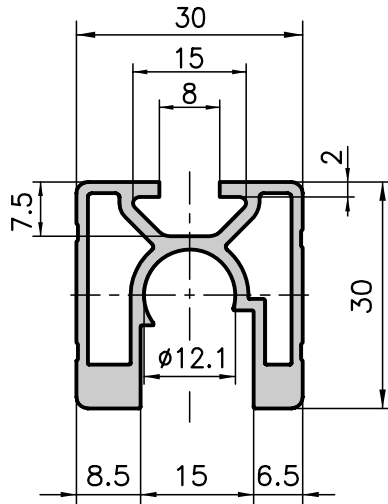

#### Application

The basic material for the single and double wheeled runner (see page 121). However, it can also be used as a frame extrusion to hold thick panels in place.

### 30x50 runner extrusion type B10-9

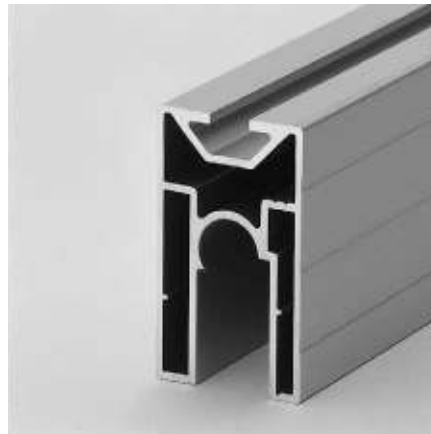
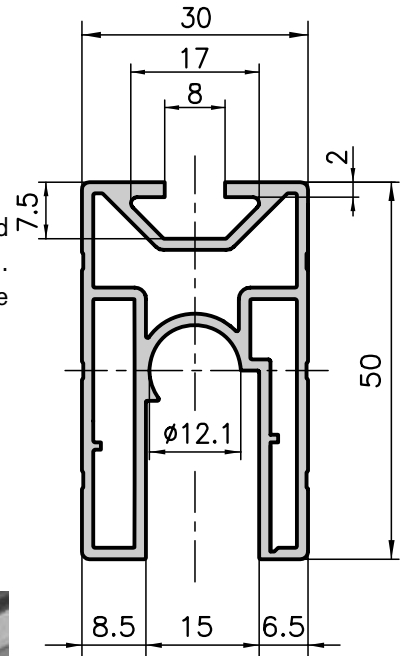

#### Technical data

$I_x$	= 3.17 cm <sup>4</sup>
$I_y$	= 2.76 cm <sup>4</sup>
$W_x$	= 2.09 cm <sup>3</sup>
$W_y$	= 1.80 cm <sup>3</sup>
Cross section area	= 2.89 cm <sup>2</sup>
Weight	= 0.8 kg/m

#### Order data      Order number

30x30 runner extrusion	
Standard length 5000 mm	B10-3-00/5000
30x30 runner extrusion	
Cut to length	B10-3-02-02/...
Extra machining	Pages 34/35

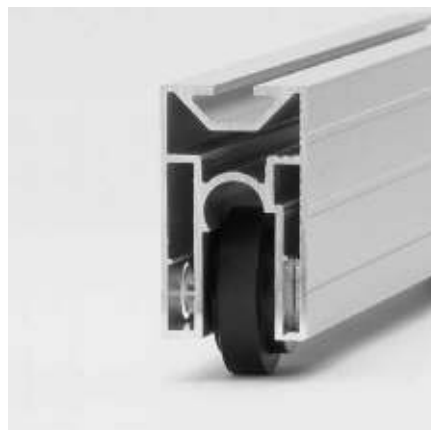

#### Technical data

$I_x$	= 9.17 cm <sup>4</sup>
$I_y$	= 4.51 cm <sup>4</sup>
$W_x$	= 3.37 cm <sup>3</sup>
$W_y$	= 2.98 cm <sup>3</sup>
Cross section area	= 3.94 cm <sup>2</sup>
Weight	= 1.1 kg/m

#### Order data      Order number

30x50 runner extrusion	
Standard length 5000 mm	B10-9-00/5000
30x50 runner extrusion	
Cut to length	B10-9-02-02/...
Extra machining	Pages 34/35

## 16x29 clamping extrusion type A05-6

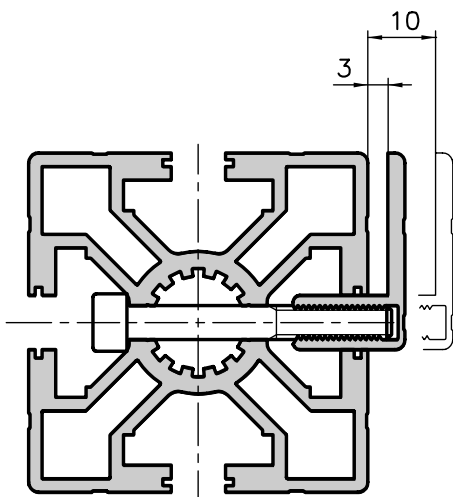
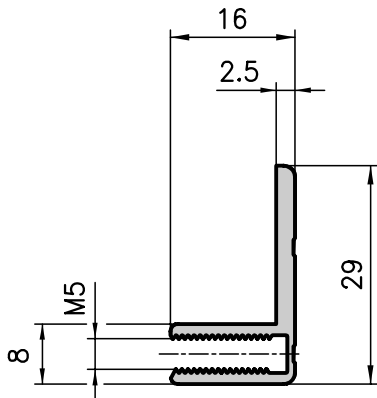

### Application

Two ingenious extrusions to clamp panels of all kinds. They can be added to any existing 8 mm slots on extrusions base 40 or 50 mm. Panels can be inserted or replaced easily, on one or two of the sides, without any need to dismantle the supporting structure!

## 16x50 double clamping extrusion type A05-7

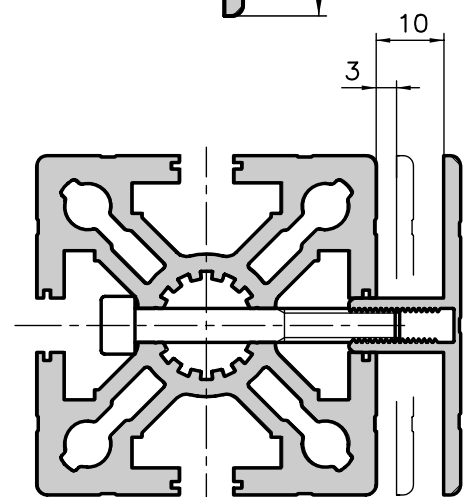
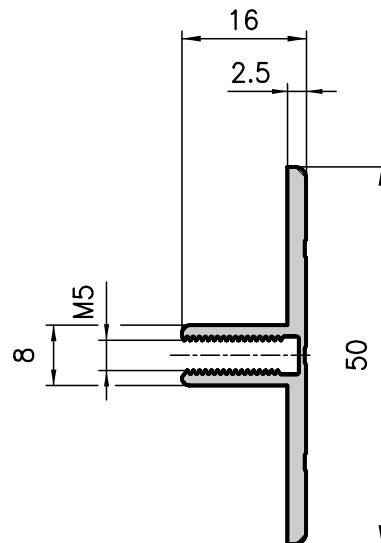

### Technical data

Cross section area = 1.18 cm<sup>2</sup>  
Weight = 0.32 kg/m

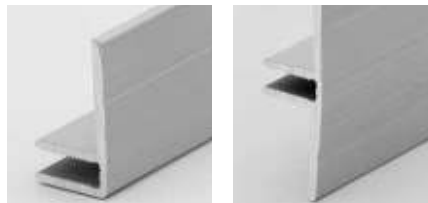

### Technical data

Cross section area = 1.70 cm<sup>2</sup>  
Weight = 0.46 kg/m

### Order data

### Order number

Clamping extrusion  
Standard length 5000 mm A05-6-00/5000  
Clamping extrusion  
Cut to length A05-6-02-02/...

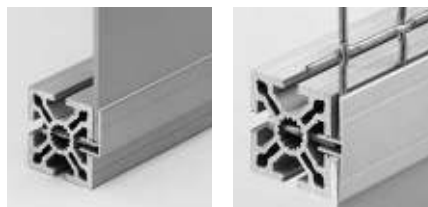

### Order data

### Order number

Double clamping extrusion  
Standard length 5000 mm A05-7-00/5000  
Double clamping extrusion  
Cut to length A05-7-02-02/...

### 13.5x50 panel clamp extrusion type A05-8

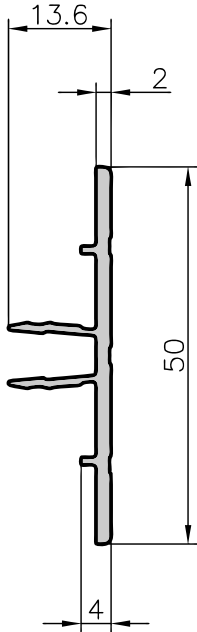

**Application**

Similar to the clamping extrusion but with the additional benefit, that this extrusion can be clipped in. Ideal for ALUCO-BOND- and DIBOND- panels or other sheets with a thickness of 2mm and respectively 4 mm (2 snap-in positions for clamping!)



**Technical data**

Cross section area = 1.26 cm<sup>2</sup>  
Weight = 0.34 kg/m

**Order data      Order number**

13.5x50 panel clamp extrusion  
Standard length 6000 mm      A05-8-00/6000  
  
13.5x50 panel clamp extrusion  
Cut to length      A05-8-02-02/...

### 8x13.5 U-clamping extrusion type B19-6

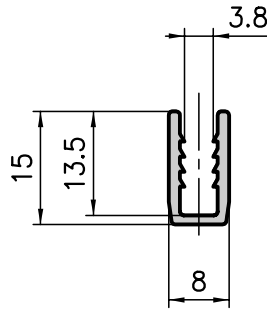

**Application**

A special extrusion for clamping the wire mesh. The U-extrusion fits into all extrusions with a base of 50, 40 and 30 mm.



**Technical data**

Cross section area = 0.53 cm<sup>2</sup>  
Weight = 0.14 kg/m

**Order data      Order number**

8x13.5 U-clamping extrusion  
Standard length 5000 mm      B19-6-00/5000  
  
8x13.5 U-clamping extrusion  
Cut to length      B19-6-02-02/...

### 11x30.5 support extrusion type B19-7

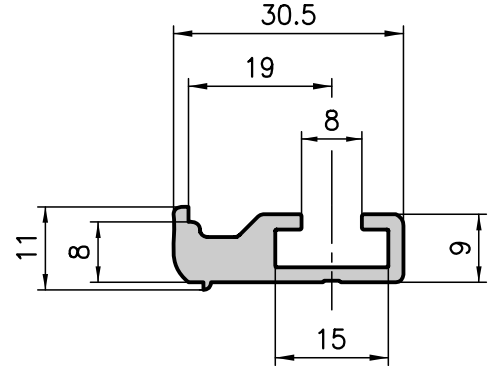

**Application**

The support extrusion is twisted into the 8 mm slots on the standard design extrusions and is used to support table tops, shelves, panels, etc.

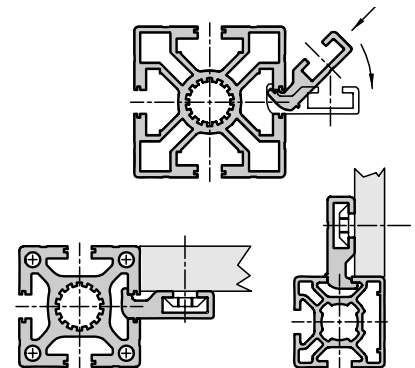
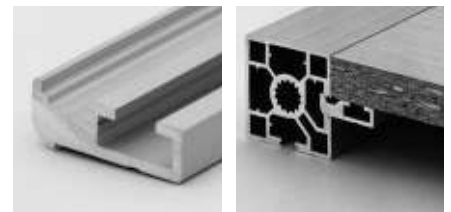

**Technical data**

Cross section area = 1.62 cm<sup>2</sup>  
Weight = 0.44 kg/m

**Order data      Order number**

Stop extrusion  
Standard length 5000 mm      B19-7-00/5000  
  
Stop extrusion  
Cut to length      B19-7-02-02/...

### Angle extrusion type A30-0/C30-0

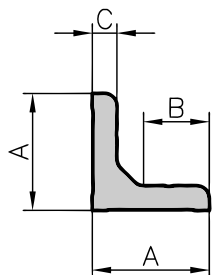

#### Dimensions

Type	A	B	C
A30-0	38	21	8
C30-0	31	17	6

#### Technical Data

	A30-0	C30-0
Cross section area	= 5.52 cm <sup>2</sup>	3.46 cm <sup>2</sup>
Weight	= 1.49 kg/m	0.94 kg/m



### Angle extrusion type A30-5

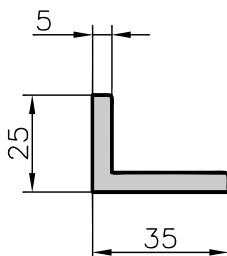

#### Application

Source material for mounting and fixing brackets or as support bracket.



### Angle extrusion type A47-0

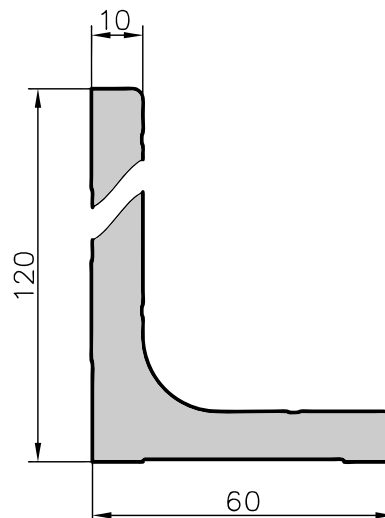

#### Application

Source material for floor bolting brackets or for reinforcements.



#### Order data

#### Order number

38x38 angle extrusion raw	
Standard length 3000 mm	A30-0-00/3000
38x38 angle extrusion raw	
Cut to length	A30-0-02-02/...
31x31 angle extrusion raw	
Standard length 3000 mm	C30-0-00/3000
31x31 angle extrusion raw	
Cut to length	C30-0-02-02/...

#### Technical data

Cross section area	= 2.74 cm <sup>2</sup>
Weight	= 0.74 kg/m

#### Order data

#### Order number

25x35 angle extrusion raw	
Standard length 5000 mm	A30-5-00/5000
25x35 angle extrusion raw	
Cut to length	A30-5-02-02/...

#### Technical data

Cross section area	= 17.15 cm <sup>2</sup>
Weight	= 4.63 kg/m

#### Order data

#### Order number

60x120 angle extrusion raw	
Standard length 3600 mm	A47-0-00/3600
60x120 angle extrusion raw	
Cut to length	A47-0-02-02/...

### Angle extrusion type A30-3

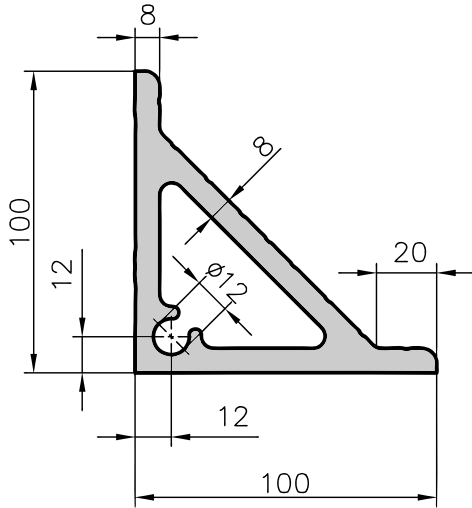

### Angle extrusion type C30-3

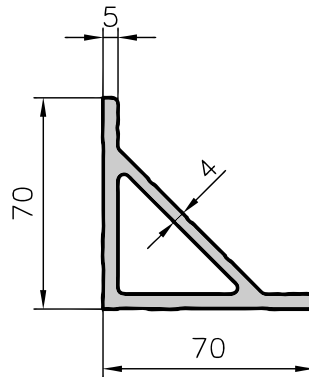

### Angle extrusion type A30-1

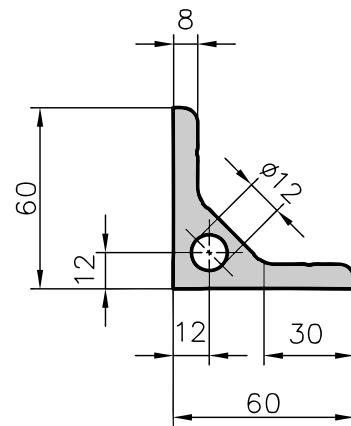

#### Application

These very strong angle extrusions are the source material for the mounting brackets. They're also used to reinforce heavily loaded constructions.

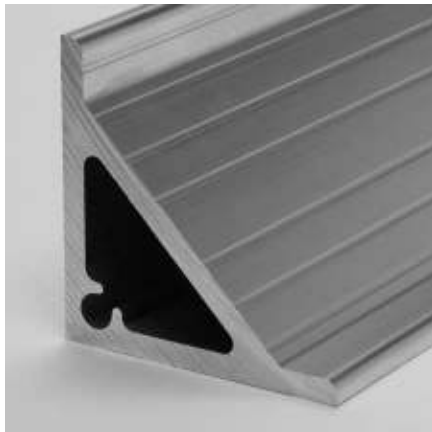

#### Technical data

Cross section area = 23.63 cm<sup>2</sup>  
Weight = 6.38 kg/m

#### Technical data

Cross section area = 9.23 cm<sup>2</sup>  
Weight = 2.49 kg/m

#### Technical data

Cross section area = 10.15 cm<sup>2</sup>  
Weight = 2.75 kg/m

#### Order data

#### Order number

100x100 angle extrusion raw  
Standard length 3000 mm A30-3-00/3000  
100x100 angle extrusion raw  
Cut to length A30-3-02-02/...

#### Order data

#### Order number

70x70 angle extrusion raw  
Standard length 3000 mm C30-3-00/3000  
70x70 angle extrusion raw  
Cut to length C30-3-02-02/...

#### Order data

#### Order number

60x60 angle extrusion raw  
Standard length 3000 mm A30-1-00/3000  
60x60 angle extrusion raw  
Cut to length A30-1-02-02/...

## Hinge extrusion type A60-6/C60-6

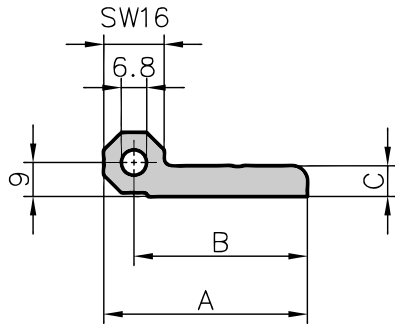

### Dimensions

Type	A	B	C
A60-6	54	46	8
C60-6	44	36	8

### Application

Source material for the unhingable and the heavy duty hinges or for producing special hinges.

### Specification

Aluminium raw



### Technical Data

	A60-6	C60-6
Cross section area	= 4.91 cm <sup>2</sup>	4.11 cm <sup>2</sup>
Weight	= 1.33 kg/m	1.11 kg/m

### Order data

### Order number

17x54 hinge extrusion	
Standard length 3000 mm	A60-6-00/3000
17x54 hinge extrusion	
Cut to length	A60-6-02-02/...
17x44 hinge extrusion	
Standard length 3000 mm	C60-6-00/3000
17x44 hinge extrusion	
Cut to length	C60-6-02-02/...

## Hinge extrusion type A60-5

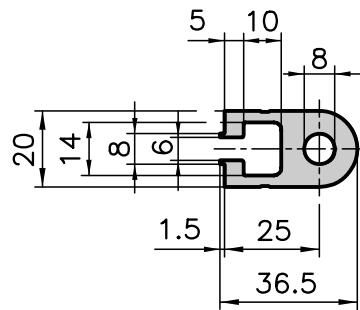

### Application

Source material for special hinges or as bearing for simple rotating-mechanism.

### Specification

Aluminium anodised



### Technical Data

Cross section area	= 4.40 cm <sup>2</sup>
Weight	= 1.19 kg/m

### Order data

### Order number

20x36.5 hinge extrusion	
Standard length 3000 mm	A60-5-00/3000
20x36.5 hinge extrusion	
Cut to length	A60-5-02-02/...

## Handle strip extrusion type B65-5

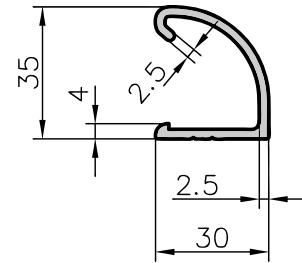

### Application

Source material for handle strips or handles with special-length.

### Specification

Aluminium anodised



### Technical Data

Cross section area	= 2.18 cm <sup>2</sup>
Weight	= 0.59 kg/m

### Order data

### Order number

30x35 handle strip extrusion	
Standard length 5000 mm	B65-5-00/5000
30x35 handle strip extrusion	
Cut to length	B65-5-02-02/...

## 55x55 rectangular tube type A19-5

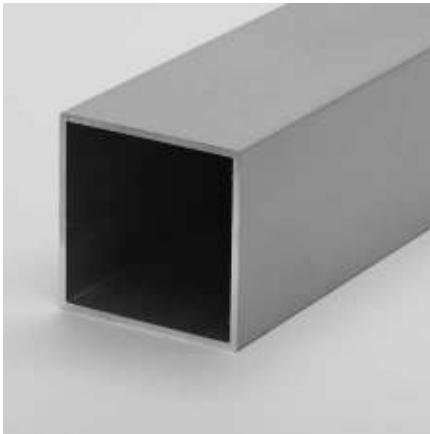
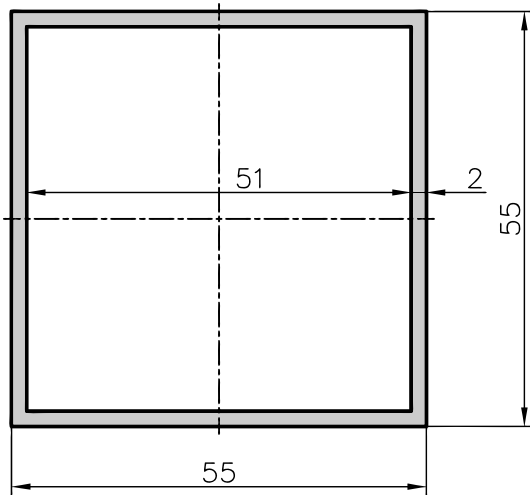

### Application

With the rectangular tube and with the combination of a 50x50 extrusion a telescope function can be easily created. Can also be used as a guidance for a counter balance in a construction with a lift gate in addition to many «classic» rectangular tube applications.

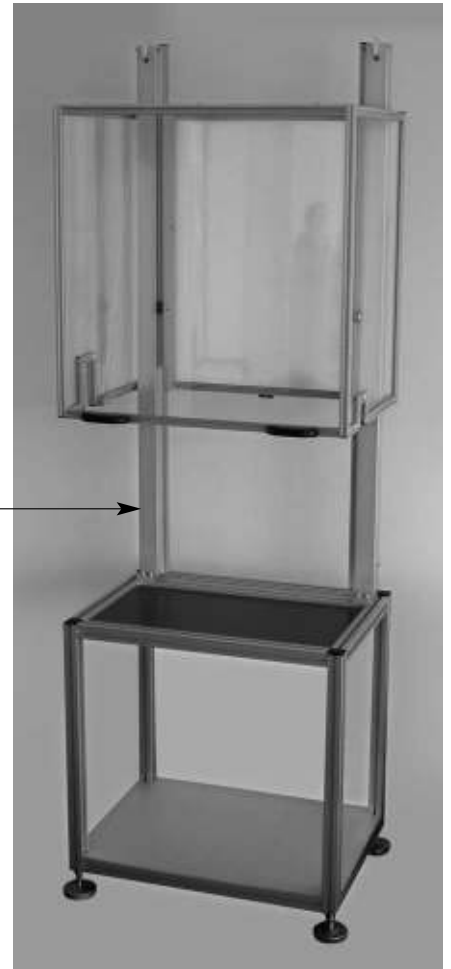

### Technical Data

$I_{x,y}$	=	21.58 cm <sup>4</sup>
$W_{x,y}$	=	7.85 cm <sup>3</sup>
Cross section area	=	4.64 cm <sup>2</sup>
Weight	=	1.25 kg/m

### Order data      Order number

55x55 rectangular tube	
Standard length 6000mm	A19-5-01/6000
55x55 rectangular tube	
Cut to length	A19-5-02-02/....



## KANYA connection technology

The extrusion connection system **PVS®** opens up new possibilities for all structural design problems, whether for machinery, transfer and handling systems, guards, machine enclosures, work benches, laboratory facilities, cabinets, room partitions or exhibition stands. Rectangular, round, square or diagonal, fixed or swivelling: KANYA is the perfect solution.

### Quick, secure connections:

KANYA PVS makes it possible to erect any structure in a very short time. The system centers around KANYA's own invention, the internationally patented PVS connector. Any extrusions can be joined together securely.

### Simple and versatile assembly:

The two fundamentals which allow you to build a structure to your own design are ease of assembly and a comprehensive range of extrusions and accessories. Modifications or additions can be easily made, when the need arises, without wasting any material.

### Highly cost-effective:

Any part can be customised. There is no need for expensive finishing or surface treatments. Expensive construction is minimised, saving time and reducing costs. All the parts can be reused repeatedly since all joints are simple to dismantle. That's what makes this system the most cost effective you can buy in the long run.

### An example of making a simple 90° connection.

All the KANYA PVS connections work on this simple principle, regardless of direction or size.



1. Insert the barrel into the hole made in the second extrusion.



2. Insert the sprung anchor into the centre hole of the barrel.



3. Push the anchor head into the slot of the first extrusion; twist 90°. Tighten the Allen screw. That's all.

## PVS®-connectors

### 1. Universal connections



The round anchor head allows the extrusions to be set in any position, however it must first be pushed into the retaining slot. **The universal connector is also available in stainless steel or providing electrical bonding.**

### 2. Standard connections



The milled anchor head allows extrusions to be added subsequently. Two types of anchor are needed to guarantee that every extrusion position is possible. **The standard connector is also available in stainless steel or providing electrical bonding.**

### 3. Combination connections



Similar to the standard connection, however with the possibility of connecting different extrusion bases among one another.

### 4. Special connections



The special anchor, which is available in different lengths, makes parallel and cross connections.

### 5. Mitre connections



The formed anchor head, 15°, 30° and 45° in both left and right designs, or with an articulated anchor head for all other angled connections.

### 6. Double mitre connections



This versatile anchor can be swivelled from 0°–90°.

### 7. Extrusion extension connections



The rigid connector guarantees an extremely stable extrusion extension.

### 8. Threaded connections



The threaded anchor enables the extrusion to be attached to other structures.

### 9. Plastic caps for connectors



These plastic caps cover the screw holes and protect it from dirt as well as improve the aesthetics.

### 1. Universal connectors

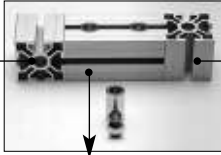

Order number			
20	30	40	50
			A20-90 (-I/-P)*
		C20-90 (-I/-P)*	C20-90 (-I/-P)*
	B20-90	B210-90 (-I/-P)*	B210-90 (-I/-P)*
D20-90	D20-90	D210-90 (-I/-P)*	D210-90 (-I/-P)*
DD20-90	DD20-90	DD210-90	DD210-90
		A20-95	
		C20-95	C20-95
	B20-95	B210-95	B210-95

Extrusions with a base of			
50	40	30	20
			20 core hole 6.0 mm
A02-8			
C02-8 / C03-8			
B01-8			

Order number			
50	40	30	20
A20-90 (-I/-P)*			
C20-90 (-I/-P)*	C20-90 (-I/-P)*		
B210-90 (-I/-P)*	B210-90 (-I/-P)*	B20-90	
D210-90 (-I/-P)*	D210-90 (-I/-P)*	D20-90	D20-90
DD210-90	DD210-90	DD20-90	DD20-90
A20-95			
C20-95	C20-95		
B210-95	B210-95	B20-95	

\*....-P = universal connectors with electrical bonding  
\*....-I = Universal connectors stainless steel

### 2. Standard connectors

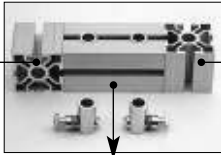

Order number			
20	30	40	50
			A20-10(-I/-P)*
		C20-10(-I/-P)*	
	B20-10(-I/-P)*		
D20-10(-I/-P)*			
DD20-10			
		A20-50	
		C20-50	
	B20-50		

Extrusions with a base of			
50	40	30	20
			20 core hole 6.0 mm
A02-8			
C02-8 / C03-8			
B01-8			

Order number			
50	40	30	20
A20-20(-I/-P)*			
	C20-20(-I/-P)*		
		B20-20(-I/-P)*	
			D20-20(-I/-P)*
			DD20-20
A20-51			
	C20-51		
		B20-51	

\*....-P = universal connectors with electrical bonding  
\*....-I = Universal connectors stainless steel

### 3. Combination connectors

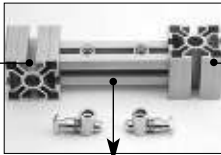

Order number			
20	30	40	50
AB20-10	AB20-10	A20-10	
CB20-10	CB20-10		C20-10
B20-10		B210-10	B210-10
	D20-10	D210-10	D210-10
	DD20-10	DD210-10	DD210-10
		C20-50	
		B210-50	B210-50

Extrusions with a base of			
50	40	30	20
			20 core hole 6.0 mm
C02-8 / C03-8			
B01-8			

Order number			
50	40	30	20
	A20-20	AB20-20	AB20-20
C20-20		CB20-20	CB20-20
B210-20	B210-20		B20-20
D210-20	D210-20	D20-20	
DD210-20	DD210-20	DD20-20	
C20-51			
B210-51	B210-51		

### 4. Special connectors

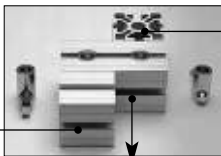

Order number			
20	30	40	50
AB20-10	AB20-10	A20-10	A20-10
CB20-15	CB20-15	C20-15	C20-15
B20-15	B20-15	B210-15	B210-15
on request	x	A20-50	A20-50
on request	x	x	x
on request	x	x	x

Extrusions with a base of			
50	40	30	20
A02-8			
C02-8 / C03-8			
B01-8			

Order number			
50	40	30	20
A20-20	A20-20	AB20-20	AB20-20
C20-25	C20-25	CB20-25	CB20-25
B210-25	B210-25	B20-25	B20-25
A20-51	A20-51	x	on request
x	x	x	on request
x	x	x	on request

## 5a. Mitre connectors with formed anchor

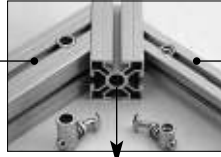

Order number

20*	20	30	40	50
DD221-α	D221-α	B221-α	C22-α	A22-α
DD221-α	D221-α	B221-α	C22-α	
DD22-α	D22-α	B22-α		
DD22-α	D22-α			

Code α 15° = -15, α 30° = -30, α 45° = -45 \*core hole 6.0 mm

Extrusions with a base of

50
40
30
20

Order number

50	40	30	20	20*
A23-α	C23-α	B231-α	D231-α	DD231-α
	C23-α	B231-α	D231-α	DD231-α
		B23-α	D23-α	DD23-α
			D23-α	DD23-α

Code α 15° = -15, α 30° = -30, α 45° = -45 \*core hole 6.0 mm

## 5b. Mitre connectors with an articulated anchor

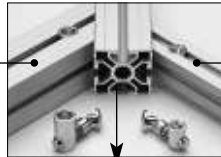

Order number

20	30	40	50
D221-00	B221-00	C22-00	A22-00
D221-00	B221-00	C22-00	
D22-00	B22-00		
D22-00			

Extrusions with a base of

50
40
30
20

Order number

50	40	30	20
A22-00	C22-00	B221-00	D221-00
	C22-00	B221-00	D221-00
		B22-00	D22-00
			D22-00

## 5c. Mitred connectors with an formed anchor 90°

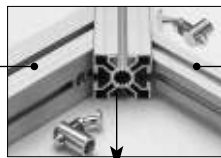

Order number

30	40	50
B221-α	C22-α	A22-α
B221-α	C22-α	
B22-α		

Code α 15° = -19, α 30° = -39, α 45° = -49

Extrusions with a base of

50
40
30

Order number

50	40	30
A23-α	C23-α	B231-α
	C23-α	B231-α
		B23-α

Code α 15° = -19, α 30° = -39, α 45° = -49

## 5d. Mitred connectors with an articulated anchor 90°

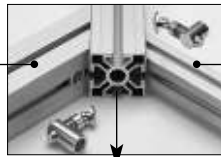

Order number

30	40	50
B221-90	C22-90	A22-90
B221-90	C22-90	
B22-90		

Extrusions with a base of

50
40
30

Order number

50	40	30
A22-90	C22-90	B221-90
	C22-90	B221-90
		B22-90

### 6. Double mitre connectors

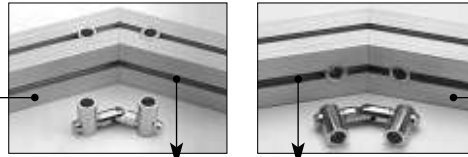

Order number

B01-8	C02-8	A02-8	20*	20	30	40	50
							A24-10
							C24-10
							B24-10
							D24-10
							DD24-10
							A24-51
							C24-51
							B24-51

\*core hole of 6.0 mm

Extrusions with a base of

50
40
30
20
20 core hole 6.0 mm
A02-8
C02-8 / C03-8
B01-8

Order number

50	40	30	20	20*	A02-8	C02-8	B01-8
							A24-19
							C24-19
							B24-19
							D24-19
							-
							A24-59
							C24-59
							B24-59

\*core hole of 6.0 mm

### 7. Extrusion extension connectors

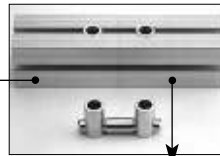

Order number

B01-8	C02-8	A02-8	20*	20	30	40	50
							A24-00
							C24-00
							B24-00
							D24-00
							DD24-00
							A24-50
							C24-50
							B24-50

\*core hole of 6.0 mm

Extrusions with a base of

50
40
30
20
20 core hole 6.0 mm
A02-8
C02-8 / C03-8
B01-8

### 8. Threaded connectors



Order number

Thread	M6	M8
	on request	A20-60
	on request	C20-60
	B20-66	B20-60
	D20-66	D20-60
	DD20-66	
	on request	A20-65
	on request	C20-65
	on request	B20-65

Extrusions with a base of

50
40
30
20
20 core hole 6.0 mm
A02-8
C02-8 / C03-8
B01-8

## Covering cap for PVS-connector

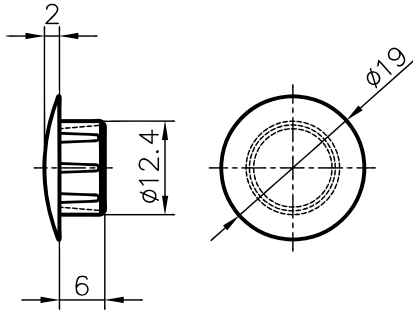

Base 50/40

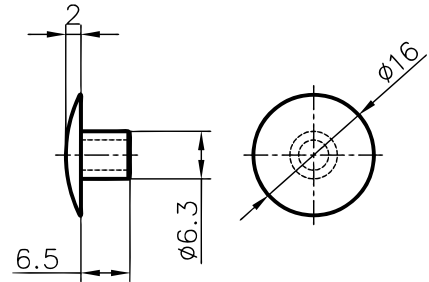

Base 30



### Application

The covering cap for the PVS-connectors have two functions: aesthetics and protection. With the connector on a face side of an extrusion, it covers the visible part of the connector.

If the application is in a dirty environment, it is wise to protect the screws from dirt to allow functionality.

### Specification

Material PE, gray



Order data	Order number
------------	--------------

#### Plastic cap

Base 40/50	A40-99
Base 30	B40-99

## Technical data for aluminium extrusion connectors

### Thrusts

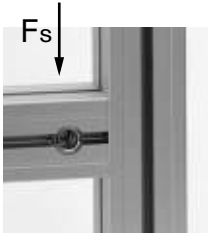

That chart shows the shearing forces in relation to torque and number of connectors of the most important extrusion combinations.

At a torque of 30Nm lies the shearing force for a connection with one connector at approximately 400N.

Recommended torque:

- Extrusion base 50/40: 30–35Nm
- Extrusion base 30/20 20–25Nm
- Extrusion base 20 (Ø6): max. 6Nm

### Suggestion:

The tightening torques should not exceed 35Nm: ⇨ The anchor head may be damaged or broken.

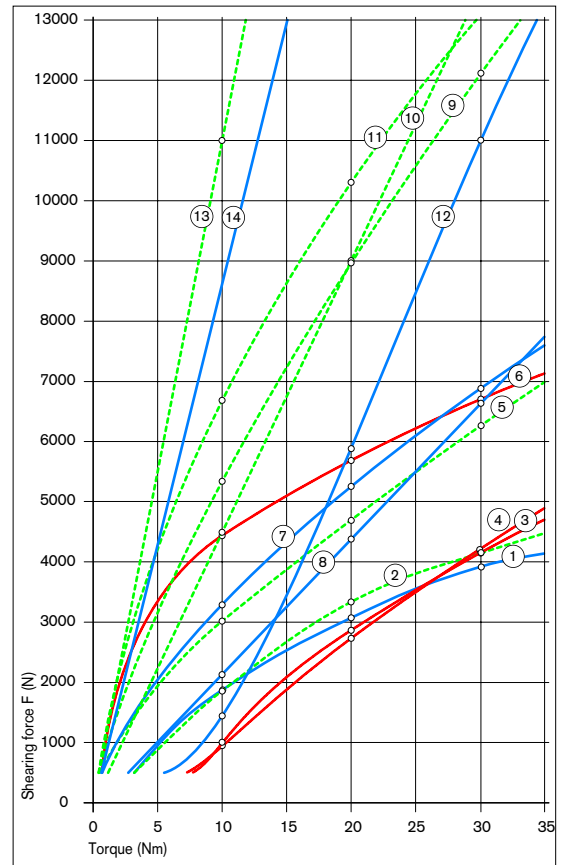

### Tractive forces



No.	extrusion	joints	No.	extrusion	joints
1	50x50	1	8	50x150	3
2	40x40	1	9	40x120	3
3	30x30	1	10	80x80	4
4	30x50	1	11	40x160	4
5	40x80	2	12	100x100	4
6	30x100	2	13	80x160	8
7	50x100	2	14	100x200	8

Those in the chart stated tractive forces are approximate value.

Conditions: Preload of connectors with max. torque!

Tractive force Extrusion	Fz Universal connectors	Fz Standard connectors
Base 50	14'000N	10'000N
Base 40	14'000N	10'000N
Base 30	4'000N	3'500N
Base 20	2'000N	1'800N



## KANYA connecting technique: PVS®-EASY

This innovative connecting technology is patented in the EU and in other important industrial countries. It boasts 3 significant characteristics:

- simple
- high-strength
- cost-efficient

The self-cutting thread-insert with a fixed screw DIN 912 will be screwed in the central extrusion hole. By ripping off the slot in the extrusion, access to the screw is enabled. The screw and the nut which is set in the other extrusion result in an extremely strong connection.

On the extrusions without a rip off slot, the opening will be machined (for example with a router).

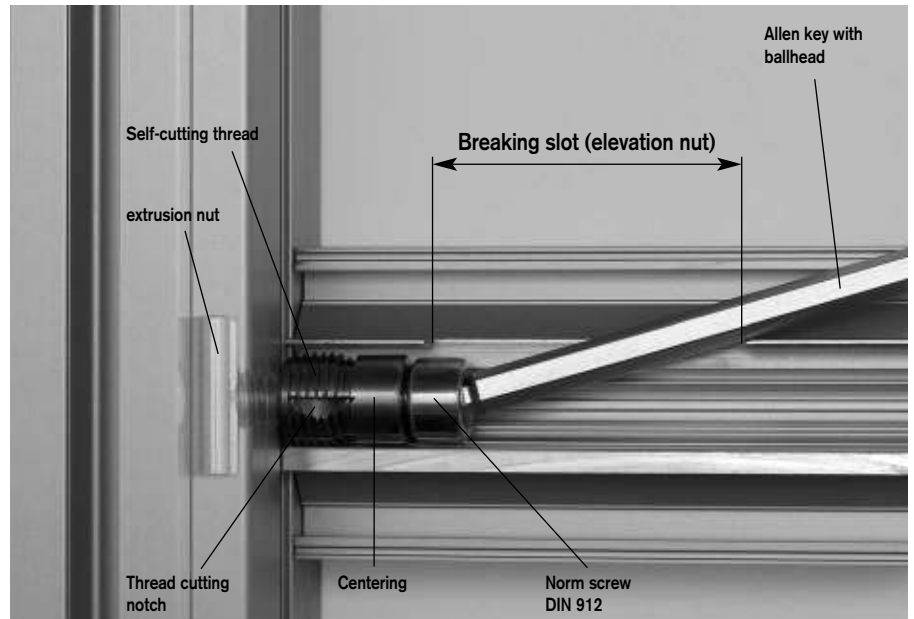

### Remark

PVS®-EASY : special steel surface treated

screw: steel 8.8, galvanized

extrusion nut: steel 8.8, galvanized

### Order data

### Order number

#### Universal connector PVS®-EASY

extrusion base 50	AE20-00
extrusion base 40	CE20-00
extrusion base 30	BE20-00

### Scope of delivery

PVS®-EASY, screw, extrusion nut



Ripped open slot



PVS®-EASY screw in (self-cutting)



Extrusion mounting



## Make LIGHT work of connecting extrusions!

Whether you are connecting extrusions with a small drilled hole or without any additional machining at all, the KANYA light system will save you time and money. Because of the modular design principle, the extrusions can be combined in virtually any configuration. The expansion sleeve can be used in any extrusions with core holes of ( 13.7 mm and 12.1 mm. )

See for yourself from these assembly instructions just how simple and reliable the KANYA LIGHT system really is!

### PVS light (with a flange plate)

#### Assembly instruction:

1. Insert the expansion sleeve into the extrusion core hole (set in 0.5 to 1 mm).
2. Tighten the adjusting screw (to the correct torque).
3. Fix the flange plate in place using the round-headed screw.
4. Screw extrusion A tightly to extrusion B using the flange plate – **that's all there is to it.**

### PVS superlight (without a flange plate)

#### Assembly instructions:

1. Insert the expansion sleeve into the extrusion core hole. Allow the flats to protrude by 1.5 (Ø 12.1) or 3 mm (Ø 13.7) and turn it to the required position using an extrusion.
2. Tighten the adjusting screw (to the correct torque).
3. Drill a stepped hole of Ø 8/14 into extrusion B.
4. Insert and tighten the socket-head cap screw – **that's all there is to it.**

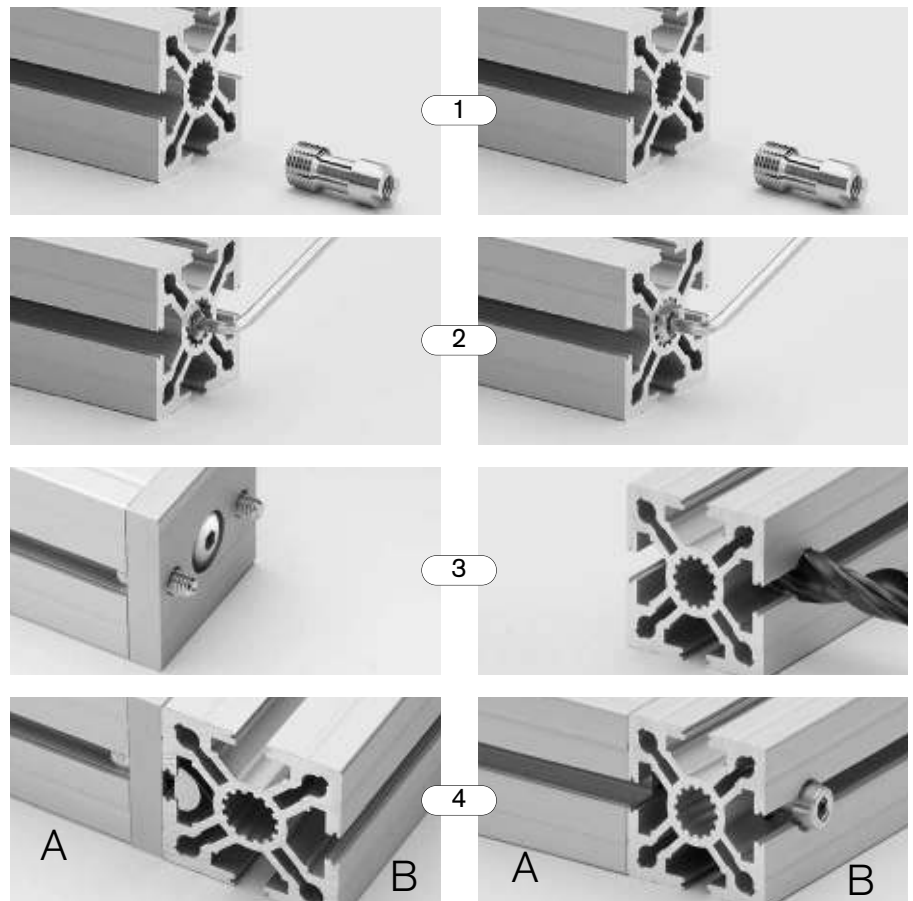

## Expansion sleeves

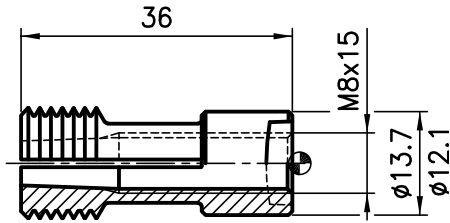

### Application

The fastening screw is inserted into the expansion sleeve. One or two expansion sleeves are required in each of the light versions, depending on the number of extrusion core holes.

### Tightening torques

Adjusting screw:  
min. 10 Nm, max. 12 Nm  
Fastening screw:  
min. 7 Nm, max. 9 Nm

### Finish

Zinc-coated steel

### Parts supplied

Expansion sleeve, adjusting screw



Order data	Order number
Extrusions of base 40 and 50 (core hole Ø13.7)	A20-00
Extrusions of base 20 and 30 (core hole Ø12.1)	B20-00

## Flange plates

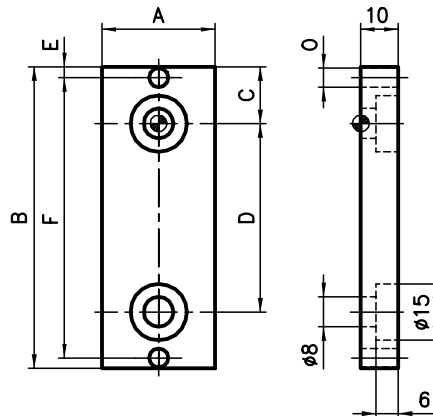

### Application

The flange plate secures the connection between two extrusions. It is fixed to one extrusion by means of a round-head socket screw and to the other with extrusion nuts and socket-head cap screws.

### Fixing set

Extrusion nuts, socket-head cap screws, round-headed socket screw(s)

### Finish

Al, anodised in natural colours

**Important!** 10 mm must be allowed for each flange plate (see sketch opposite) in calculating the extrusion cut length.

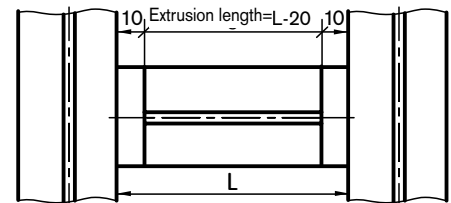

Order data	Order number
<b>Flange plate for extrusions</b>	
	<b>A B C D E F O</b>
50x50	50 50 25 - 7 36 6 A81-10
50x100	50 100 25 50 7 86 6 A81-20
40x40	40 40 20 - 5.5 29 5 C81-10
40x80	40 80 20 40 5.5 69 5 C81-20
30x30	30 30 15 - 2.8 24.4 5 B81-10
30x50	30 50 25 - 2.8 44.4 5 B81-11
30x100	30 100 25 50 2.8 94.4 5 B81-20
<b>Fixing set for combinations</b>	
50 base to 50 base	(1 round-headed socket screw) A81-10-S
50 base to 50 base	(2 round-headed socket screws) A81-20-S
40 base to 40 base	(1 round-headed socket screw) C81-10-S
40 base to 40 base	(2 round-headed socket screws) C81-20-S
40 base to 50 base	(1 round-headed socket screw) C81-11-S
40 base to 50 base	(2 round-headed socket screws) C81-21-S
30 base to 30 base	(1 round-headed socket screw) B81-10-S
30 base to 30 base	(2 round-headed socket screws) B81-20-S
30 base to 40 base	(1 round-headed socket screw) B81-11-S
30 base to 40 base	(2 round-headed socket screws) B81-21-S
30 base to 50 base	(1 round-headed socket screw) B81-12-S
30 base to 50 base	(2 round-headed socket screws) B81-22-S



hole  
in  
one

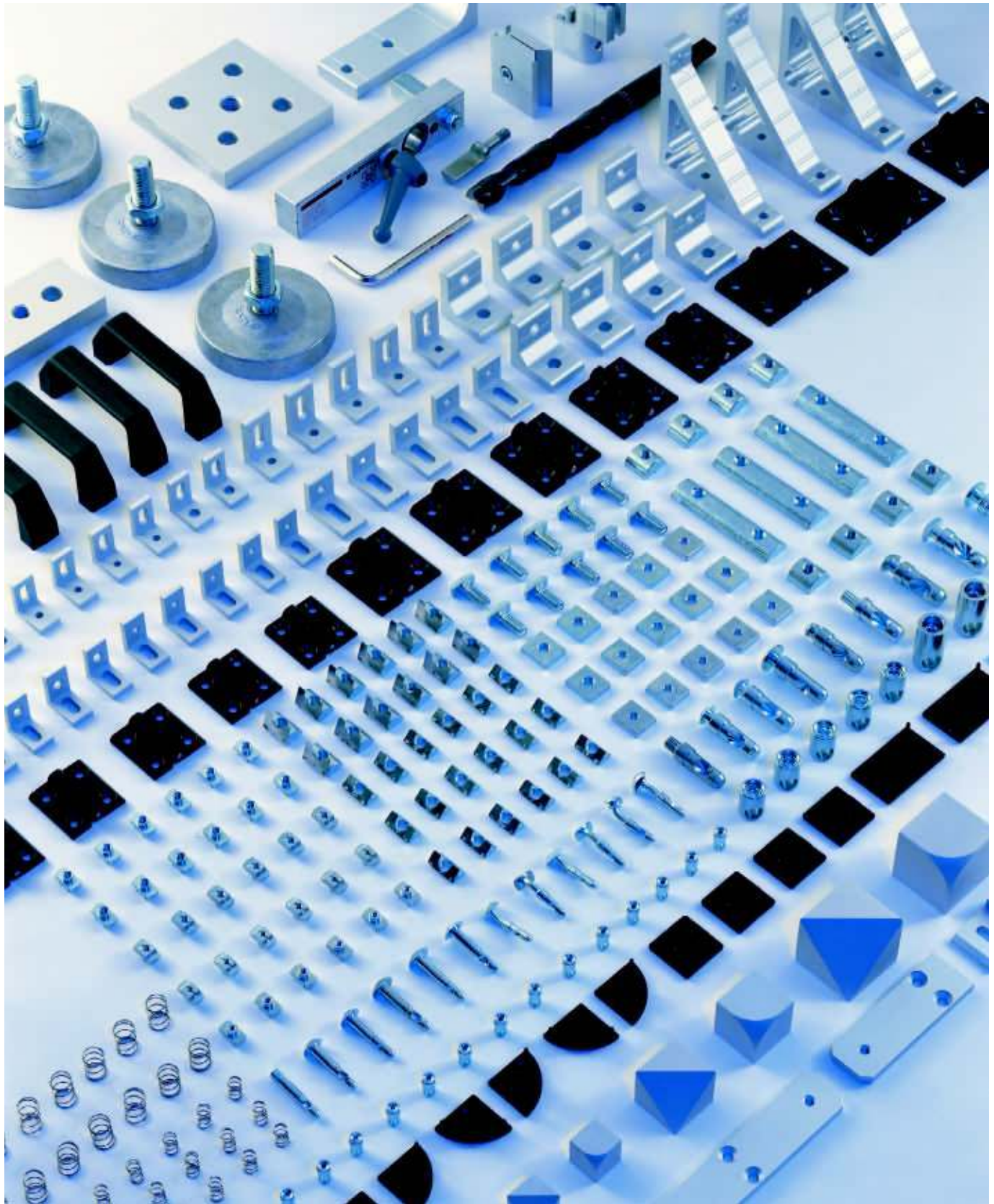

## The QUICK way to combine extrusions!

The extensive range of co-ordinated accessories enhances the cost-effectiveness of the KANYA modular extrusion building system. The best use of system extrusions is made when working with all the matching parts. Getting everything from one supplier saves time and a great deal of irritation, not to mention money.

Customer-specific accessories are available or can be specially made to order – yet another advantage of over 25 years experience in system building.



## The A-Z of extrusion parts – we have them all!

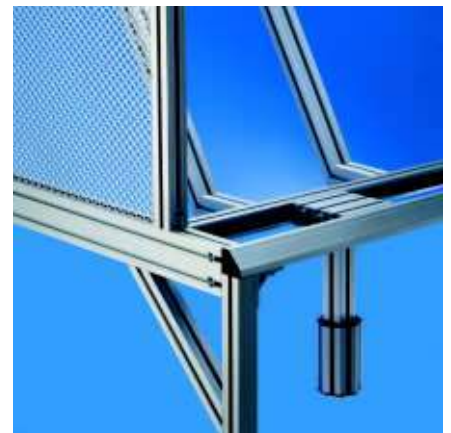

## Mounting brackets

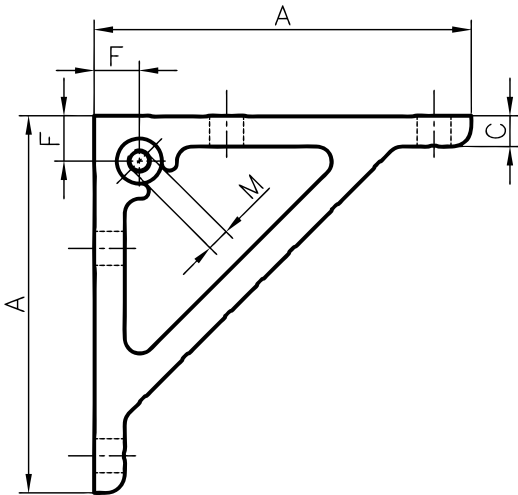

### Application

Mounting brackets are simple joining parts which can also be used in combination with PVS. They are used primarily for reinforcement. They can also be used for fixing panels in place thanks to the integral threaded insert.

### Specification

Aluminium, matt,  
anodised in natural colours

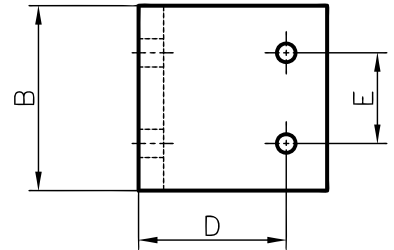
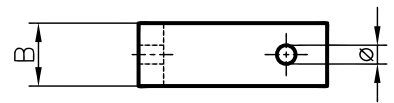
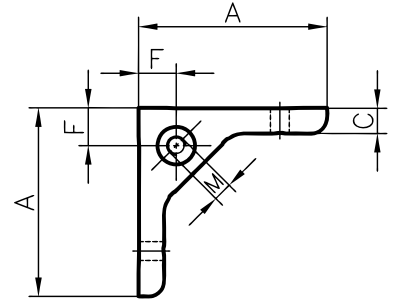
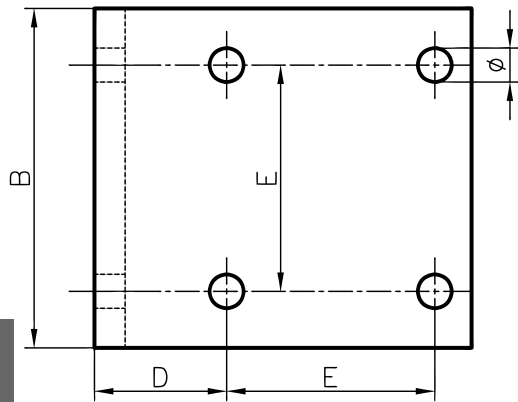
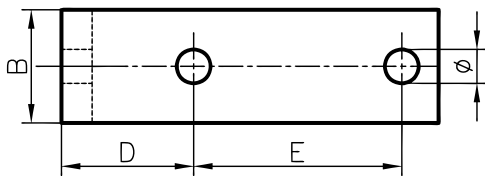

Order data								Order number
A	B	C	D	E	F	Ø	M*	
100	30	8	35	55	12	9	-	A30-30
100	30	8	25	50	-	9	-	A30-31
100	75	8	25	50	-	9	-	A30-32
100	30	8	35	55	12	9	M6	A30-40
100	20	8	35	55	12	6.5	-	B30-30
100	20	8	35	55	12	6.5	M6	B30-40
70	25	5	20	40	-	6.5	-	C30-30
70	65	5	20	40	-	6.5	-	C30-32

\*insert



Order data								Order number
A	B	C	D	E	F	Ø	M*	
60	20	8	45	-	12	6.5	-	B30-10
60	20	8	45	-	12	6.5	M6	B30-20
60	30	8	45	-	12	9	-	A30-10
60	30	8	45	-	12	9	M6	A30-20
38	30	8	25	-	-	9	-	A30-00
38	80	8	25	50	-	9	-	A30-02
31	20	6	20	-	-	6.5	-	C30-00
31	60	6	20	40	-	6.5	-	C30-02

\*insert

## Mounting bracket and dowel

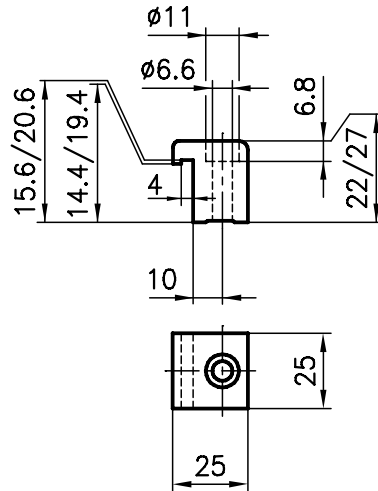
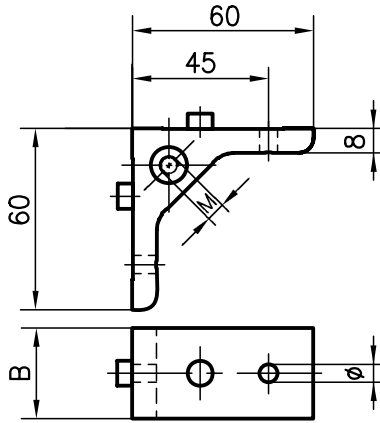

## Clamping block

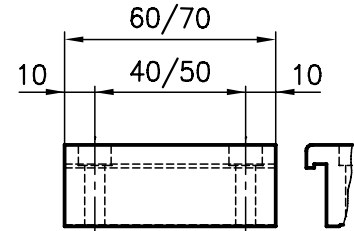

### Application

The mounting bracket and dowel are used in any application where the extrusions are subjected to torsion but must not twist. A safe extrusion connection.

### Specification

Aluminium, matt,  
anodised in natural colours



### Application

To connect two extrusions of base 50 or 40 in parallel or crossing. Two blocks are required to create a parallel connection.



### Specification

Block: Aluminium, matt, anodised  
in natural colours  
Screw: Zinc-coated steel

### Parts supplied

1/2 clamping block(s)  
Screws / threaded plates

Order data	Order number
B Ø M	
30 9 -	A30-11
20 6.5 -	B30-11
30 9 M6	A30-21
20 6.5 M6	B30-21

Order data	Order number
<b>Raw block extrusion</b>	
<b>Base 50</b>	
Standard length 3000 mm	A34-0-00/3000
Cut to length	A34-0-02-02/ ...
<b>Base 40</b>	
Standard length 3000 mm	C34-0-00/3000
Cut to length	C34-0-02-02/ ...

Order data	Order number
<b>Single clamping blocks</b>	<b>Base</b>
Cross connection	50 40
Parallel connection	A34-01 C34-01
<b>Double clamping blocks</b>	A34-11 C34-11
Cross connection	A34-02 C34-02
Parallel connection	A34-22 C34-22

## Uniblock

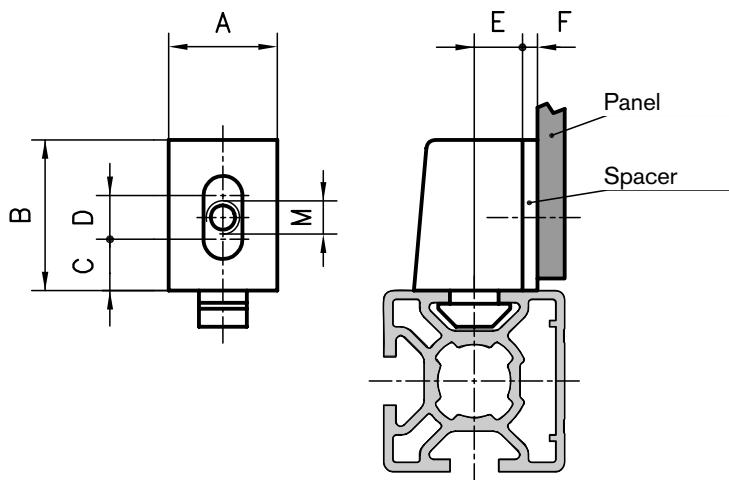

### Application

The uniblock is used to secure all sorts of panels in place. The uniblock can be attached to the extrusion without having to use any screws thanks to the attached anchor-head. The panel is then screwed to the uniblock. The captive square nut provides a large tolerance range. Different spacers can be used to give the required gap between the panel and the edge of the extrusion.



### Specification

PA-GF, black,  
square nut, zinc-coated steel

## Clamping block

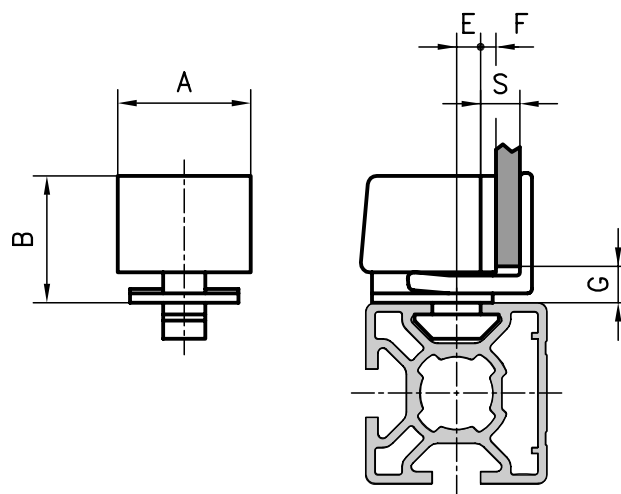

### Application

The clamping block can be used to mount panels to extrusions without any additional fixings. The panel is clamped in the block by means of a toothed slide, simply and without having to use a tool. Spacers can also be used in the clamping block to give the required gap between the panel and the edge of the extrusion.

### Specification

PA-GF, black



Order data	Order number
A B C D E M	
<b>Uniblock extrusion base 50</b>	
18 25 7.5 9.5 16	M4 A30-94
	M5 A30-95
	M6 A30-96
<b>Uniblock extrusion base 40</b>	
18 25 7.5 9.5 11	M4 C30-94
	M5 C30-95
	M6 C30-96
<b>Uniblock extrusion base 30</b>	
18 25 11 4.5 6	M4 B30-94
	M5 B30-95
	M6 B30-96
<b>Uniblock extrusion base 20</b>	
12 16 5.5 4.5 5	M4 D30-94

Order data	Order number
<b>Spacers for extrusion base 50 / 40 / 30</b>	
F = 2 mm	A302-97
3 mm	A303-97
5 mm	A305-97
<b>Spacers for extrusion base 20</b>	
F = 1 mm	D301-97
2 mm	D302-97
3 mm	D303-97
4 mm	D304-97

Order data	Order number
A B E G Smax.	
<b>Clamping block extrusion base 50</b>	
22 21 13.5 5 10 mm	A30-90
<b>Clamping block extrusion base 40</b>	
22 21 8.5 5 10 mm	C30-90
<b>Clamping block extrusion base 30</b>	
22 21 3.5 5 8 mm	B30-90
<b>Spacers for extrusion base 50 / 40 / 30</b>	
F = 2 mm	A302-98
3 mm	A303-98
5 mm	A305-98

## Attachment bracket

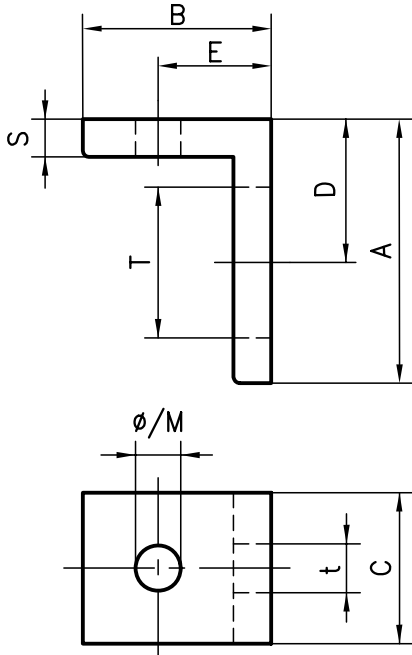

### Application

The fixing angle is used to mount additional equipment, panelling, work tops, valves, electrical switchgear, etc.

The advantage of these is that they are slotted on one side, allowing fine adjustment.

### Specification

Aluminium, matt, anodised in natural colours

## T-bolts

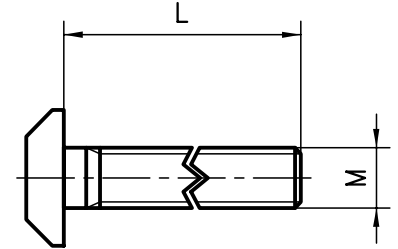

### Application

T-bolts are used to fasten all types of components and are simple to insert, even after assembly. The anti-twist shape is a help during assembly.

### Specification

8.8 steel, zinc-coated

### Scope of delivery

Screw, hexagonal nut, washer



Order data							Order number				
A	B	C	D	E	S	Txt	Ø	Thread	Through-hole Ø	Thread M	
45	45	20	25	25	5	20x6.5	6.2	M6	A30-76	A30-86	
35	25	20	19	15	5	20x6.5	4.2	M4	A30-54	A30-64	
35	25	20	19	15	5	20x6.5	5.2	M5	A30-55	A30-65	
35	25	20	19	15	5	20x6.5	6.2	M6	A30-56	A30-66	
25	25	15	14	15	4	13.5x6	3.2	M3	B30-53	B30-63	
25	25	15	14	15	4	13.5x6	4.2	M4	B30-54	B30-64	
25	25	15	14	15	4	13.5x6	5.2	M5	B30-55	B30-65	
25	25	15	14	15	4	13.5x6	6.2	M6	B30-56	B30-66	

Further dimensions on request

Order data		Order number	
MxL		extrusion base	
M8x20		50 / 40	30
M8x25		A35-20	
M8x30		A35-25	
M8x40		A35-30	
M8x60		A35-40	
		A35-60	
M6x15			B35-15
M6x18		C35-18	
M6x20			B35-20
M6x25		C35-25	
M6x30		C35-30	B35-30
M6x40			B35-40

## Threaded plates

Extrusions base of 50 and 40

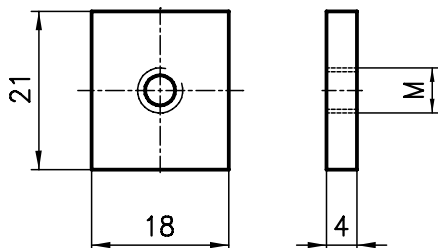

Extrusions base of 30 and 20

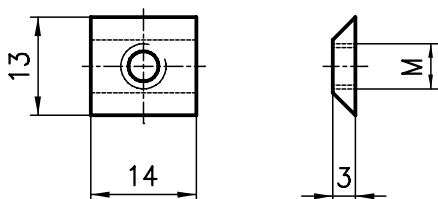

## Double threaded plates

Extrusions base of 50 and 40

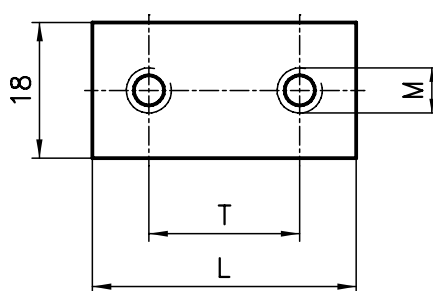

Base 30 and 20

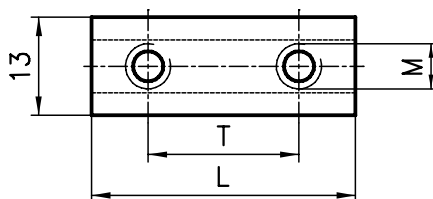

## Halfround threaded plates Base 50

Extrusions base of 50

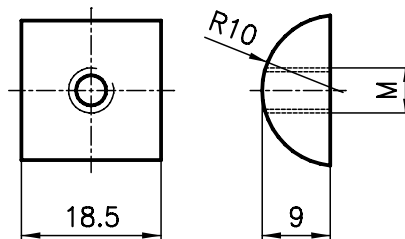

### Application

For attaching components which are anything up to medium weight.

### Specification

Threaded plate: zinc-coated steel  
Retaining spring: spring steel

### Measurement data

Extrusion base	L	T	M
50 / 40	45	30	M6
	30	18	M5
30 / 20	45	30	M6
	30	18	M5

### Application

The M6 double extrusion nuts are used for attaching hinges (page 136/137), M5 is used for arrester plate (page 143).

### Application

Halfround threaded plates can only be used with 50 mm base extrusions. These plates are only available threaded M10.

### Specification

zinc-coated steel



Order data      Order number

Threaded plates	extrusion base		
	50 / 40	30 / 20	20
Thread M			
M3	-	B32-30	D32-30
M4	A32-40	B32-40	D32-40
M5	A32-50	B32-50	D32-50
M6	A32-60	B32-60	D32-60
M8	A32-80	-	-

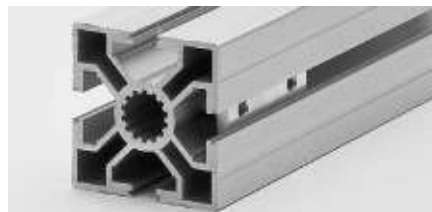

Order data      Order number

Double extrusion nuts	Base	
	50 / 40	30 / 20
Thread M		
M5	A32-58	B32-58
M6	A32-68	B32-68



Order data      Order number

Halfround threaded plates Base 50	Thread M	Order number
		M6
M8	A32-81	
M10	A32-91	

## Extrusion nuts Clamping nuts

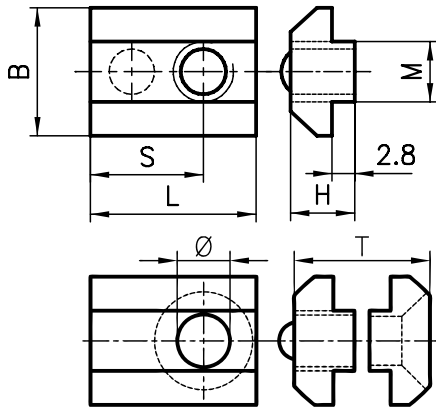

### Measurement data

Extrusion Base	B	H	L	S	T	Ø
50	18	12.2	25	15	-	-
40	17	8	22	15	-	-
50/50	18	12.2	25	15	23	6.5
50/40	18	12.2	25	15	23	6.5
40/40	17	8	25	15	19	6.5

### Application

The extrusion nut is recommended for securing heavy components with high tightening torques. Threaded plates and extrusion nuts are inserted before assembly into the end of the extrusion slots.

### Specification

zinc-coated steel



### Order data

### Order number

Extrusion nuts Thread M	Extrusion base		
	50	40	
M6	A32-63	C32-63	
M8	A32-83	C32-83	
Clamping nuts M6	50/50	50/40	40/40
	A32-69	A32-69	C32-69

## Light extrusion nuts

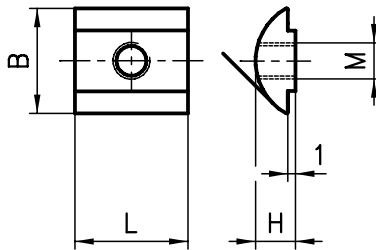

### Measurement data

Extrusion Base	B	H	L
50	14	7.8	20
40	13.6	5.9	22
30	11	4.1	20

### Application

The advantage of the light extrusion nuts is that they can also be inserted diagonally into the extrusion slots. The disadvantage is that the tightening torques > 12 N may result in dents in the aluminium extrusion. Raw steel bars are available if you wish to machine special nuts.

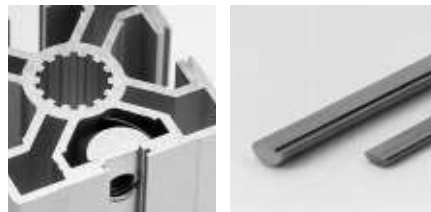

### Order data

### Order number

Light extrusion nuts Thread M	Extrusion base		
	50	40	30
M4	A32-45	C32-45	B32-45
M5	A32-55	C32-55	B32-55
M6	A32-65	C32-65	B32-65
M8	A32-85	C32-85	B32-85
Extrusion (raw) 1.5 m			
	A32-52	C32-52	B32-52

## Double extrusion nuts

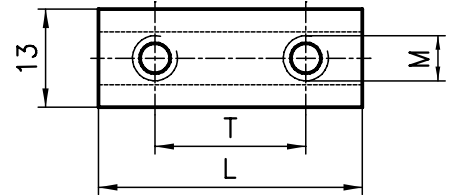

### Measurement data

#### Double extrusion nuts

Extrusion base	B	H	L	T	M
50	18	12.2	80	50	M8
40	17	8	60	40	M8

#### Light double extrusion nuts

Extrusion base	B	H	L	T	M
50	14	7.8	40	30	M6
40	13.6	5.9	40	30	M6
30	11	4.1	40	30	M6
30	11	4.1	30	18	M4

### Application

Double extrusion nuts should be used with PVS threaded connectors where extremely high strength joints are required. Light double extrusion nuts are used for the assembly of hinges (page 136/137) and quick-release fasteners (page 143).



### Order data

### Order number

Double extrusion nuts Thread M	Extrusion base		
	50	40	30
M8	A32-84	C32-84	-
Light double extrusion nuts M6 M4			
	A32-67	C32-67	B32-67
	-	-	B32-47

## Hammer nuts

### Base 50/40

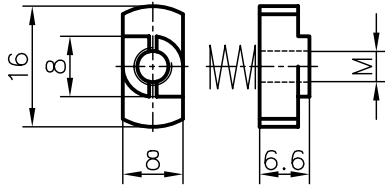

### Base 30/20

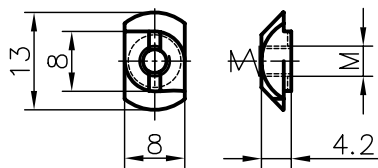

### Application

The spring and rhomboid nuts can be used for the same purpose as the threaded plates and the extrusion nuts. They can be inserted into the extrusion slot after assembly. The nuts can be spaced close together because they are only 8 mm wide. However, their load-bearing capability is clearly lower than those of threaded plates and extrusion nuts.

### Specification

Zinc-coated steel;  
retaining springs: spring steel



## Rhomboid nuts

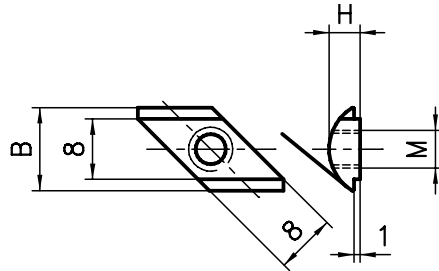

### Measurement data

Extrusion base	B	H
50/40	13.6	5.9
30/20	11	4.1

### Application

Zinc-coated steel



## Anti-twist spigots

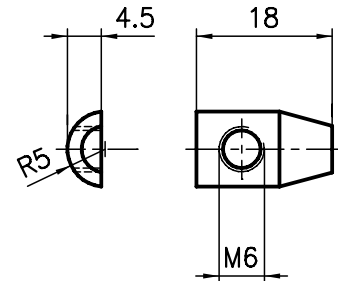

### Application

For all extrusions which are assembled with a PVS connector and which must not twist. The spigot can also be fitted to existing extrusions (does not apply to 20x20 extrusions).

### Specification

Zinc-coated steel

### Parts supplied

Spigot, adjusting screw

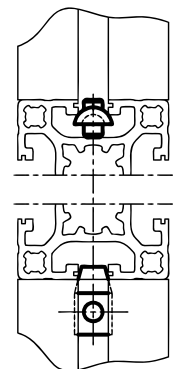

Order data	Order number	
Thread M	50/40	30/20
M3	AC31-35	BD31-35
M4	AC31-45	BD31-45
M5	AC31-55	BD31-55
M6	AC31-65	BD31-65

Order data	Order number	
Thread M	50/40	30/20
M3	-	BD31-30
M4	AC31-40	BD31-40
M5	AC31-50	BD31-50
M6	AC31-60	BD31-60

Order data	Order number	
Spigot	50/40	30/20
	AC29-00	BD29-00

## Threaded inserts

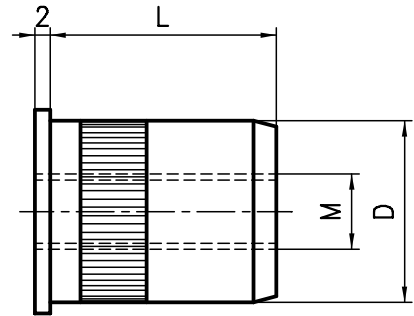
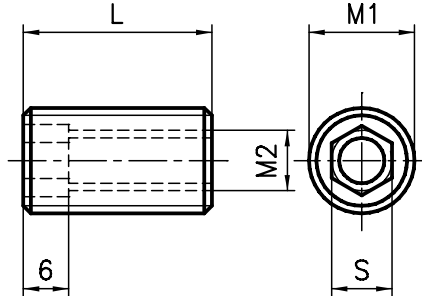
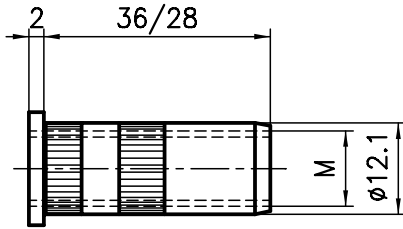

### Application

The threaded insert, which is manufactured with an external knurl, is inserted into a 12 mm hole across the line of the extrusion, enabling levelling feet and casters to be fixed to horizontal extrusions. This threaded insert can also fit in the core holes of base 30 extrusions.

### Specification

Zinc-coated steel



Order data	Order number	
	extrusion base	
Threat M	50 / 40 (L=36)	30 (L=28)
M10	C33-20	B33-20
M8	C33-22	B33-22

### Application

The screw-in threaded insert is primarily used to take levelling feet and casters or to fix end panels or base plates in place.

### Specification

Zinc-coated steel



Order data		Order number	
Threat		extrusion base	
M1	M2	S	L
M16	M12	12	25
M16	M10	10	25
M16	M8	8	25
M16	M6	6	25
M14	M10	10	25
M14	M8	8	25
M14	M6	6	25

Order data		Order number	
self-threading		Extrusion type	
-	M5	6	18
-	M6	6	18
-	M8	8	18

See also PVS-Light → Expansion sleeve (page 102)

### Application

Once the threaded insert has been pressed into the core hole of extrusions B02-6/C03-4/D01-1, feet or casters can be attached.

### Specification

Aluminium, raw

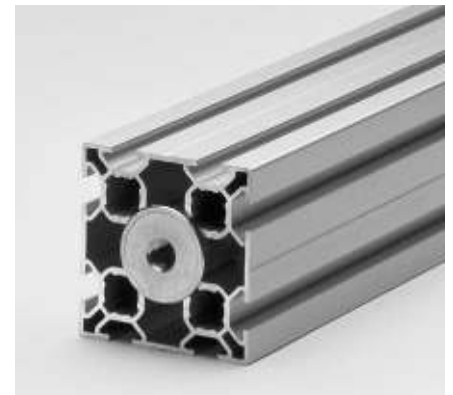

Order data		Order number		
Threat		Extrusion type		
M	D	L	B02-6	C03-4
M10	ø 24.6	30	B33-60	-
M14	ø 24.6	30	B33-64	-
M16	ø 30	30	-	C33-16
M10	ø 30.5	18	-	-

## Levelling feet

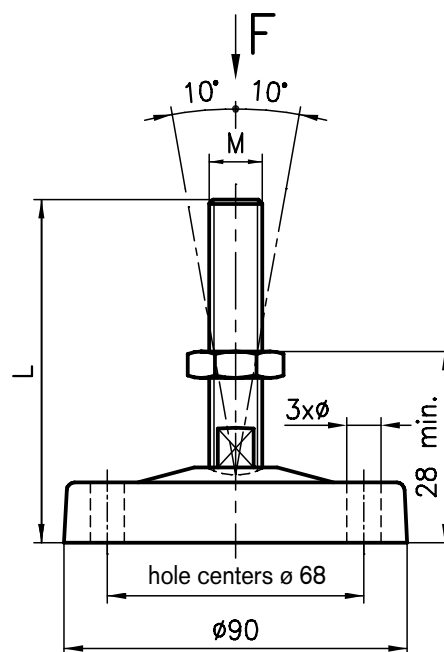
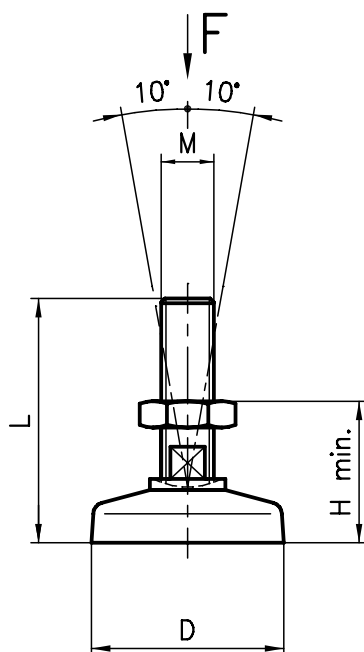
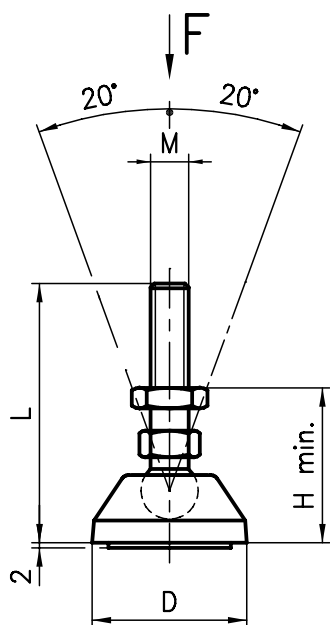

### Application

Cup: glass-filled Polyamide (PA-GF) black  
Bolt/locknut: 8.8 steel, zinc-coated  
Anti-slide pad: NBR rubber



### Order data

MxL	D	H	F	Order number
M8x37	19	20	1000 N	B43-05
M10x75	29	30	2000 N	B43-10
M10x75	39	30	3000 N	B43-11
M10x75	49	30	3000 N	B43-12

### Application

These continuously variable levelling feet are used for many different applications. The cup is attached in such a way as to compensate for uneven floors.

### Specification

Cup: PA-GF black  
Bolt/locknut: 8.8 steel, zinc-coated



### Order data

MxL	D	H	F	Order number
M10x70	50	30	2500 N	B42-50
M10x122	50	30	2500 N	B42-00
M14x65	50	25	3000 N	B42-54
M14x115	50	25	3000 N	B42-14
M16x65	50	25	3500 N	B44-50
M16x115	50	25	3500 N	B44-00

### Specification

Cup: PA-GF black or aluminium  
bolt : 8.8 steel, zinc-coated



### Order data

MxL	Ø	F	PA-GF
M14x70	9	4000 N	B45-54
M14x120	9	4000 N	B45-14
M16x70	9	5000 N	B45-50
M16x120	9	5000 N	B45-00

### Order number

MxL	Ø	F	Aluminium
M14x70	9	8000 N	B45-55
M14x70	-	8000 N	B45-56
M14x120	9	8000 N	B45-03
M14x120	-	8000 N	B45-04
M16x70	9	10'000 N	B45-51
M16x70	-	10'000 N	B45-52
M16x120	9	10'000 N	B45-01
M16x120	-	10'000 N	B45-02

Other dimensions or special feet are available on demand.

## Levelling feet with shock absorbers

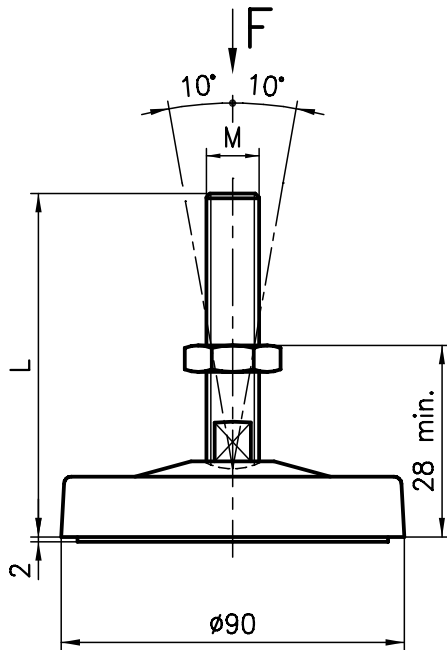

### Application

The aluminium levelling foot is available with a special shock absorber insert. This ensures that vibrating structures sit securely on the floor.

### Specification

Cup: aluminium  
 Roundel:  $\varnothing 80 \times 18$   
 Multi-layer, non-slip, vibration-absorbent, composite structure.  
 Bolt: 8.8 steel, zinc-coated



Order data		Order number
MxL	F	
M14x70	5000 N	B45-56-D
M14x120	5000 N	B45-04-D
M16x70	5000 N	B45-52-D
M16x120	5000 N	B45-02-D

## Electrically conductive levelling feet

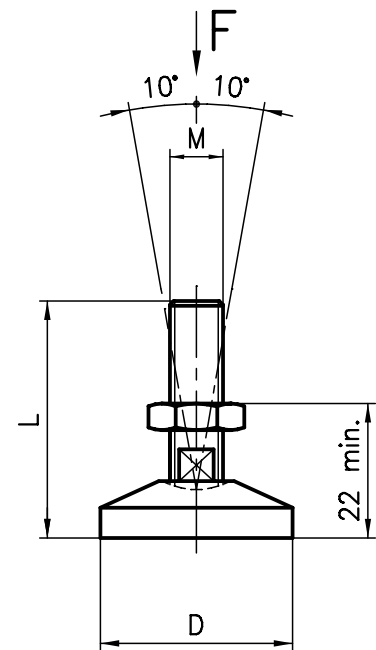

### Application

It is essential to use these levelling feet in applications where electrostatic charges must be earthed. (See also PVS connectors with electrical bonding)

### Specification

Cup: aluminium raw  
 Bolt: aluminium raw



Order data			Order number
MxL	D	F	
M14x65	30	3000 N	B42-54-P
M16x115	50	3500 N	B44-00-P

## Base plates

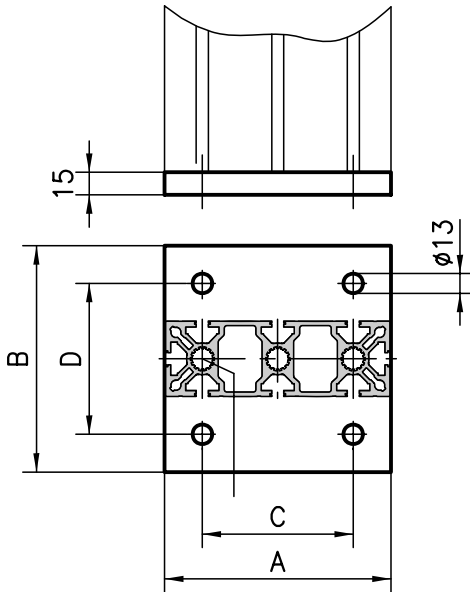

### Application

When structures are subjected to heavy loads, structural stability is extremely important. The solid steel base plate meets this requirement in every respect, guaranteeing a high level of safety.

### Specification

Steel, gunmetal finish

### Fixing kit\*

Bolt(s) M16x30



Order data	Order number				
Extrusion	A	B	C	D	
50x50	150	50	120	-	A47-50(-S)*
50x150	150	150	100	100	A47-70(-S)*
100x100	200	100	150	70	A47-80(-S)*
40x40	120	40	90	-	C47-40(-S)*
80x80	150	80	120	50	C47-80(-S)*

\*Fixing kit: add -S to the order number

## Foot plates

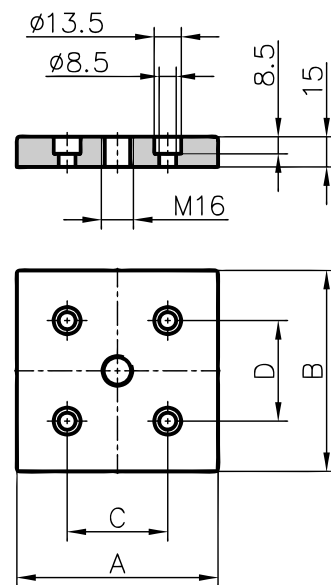

### Application

For use with extrusions without a central core hole when fixing levelling feet and casters.

### Specification

Aluminium, anodised in natural colours

### Fixing kit\*

Screws and threaded inserts



Order data	Order number				
Extrusion	A	B	C	D	
100x100	100	100	50	50	A80-20(-S)*
80x80	80	80	40	40	C80-20(-S)*
40x80	40	80	-	40	C80-24(-S)*

\*Fixing kit: add -S to the order number

## Floor bolting bracket

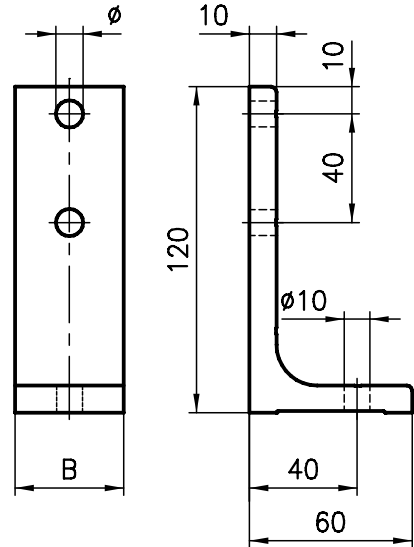

### Application

A floor bolting bracket is used when a system has been aligned and has to be bolted to the floor. It is very easy to use because its height can be adjusted in the extrusion slot and the bracket can be easily secured to the floor using anchor bolts.

### Specification

Aluminium, anodised in natural colours

### Fixing kit\*

2 screws, 2 threaded plates, 2 washers



Order data	Order number		
extrusion base	B	ø	
50/40	40	8.5	A47-00(-S)*
30	30	6.5	B47-00(-S)*

\*Fixing kit: add -S to the order number

## Double bolting bracket

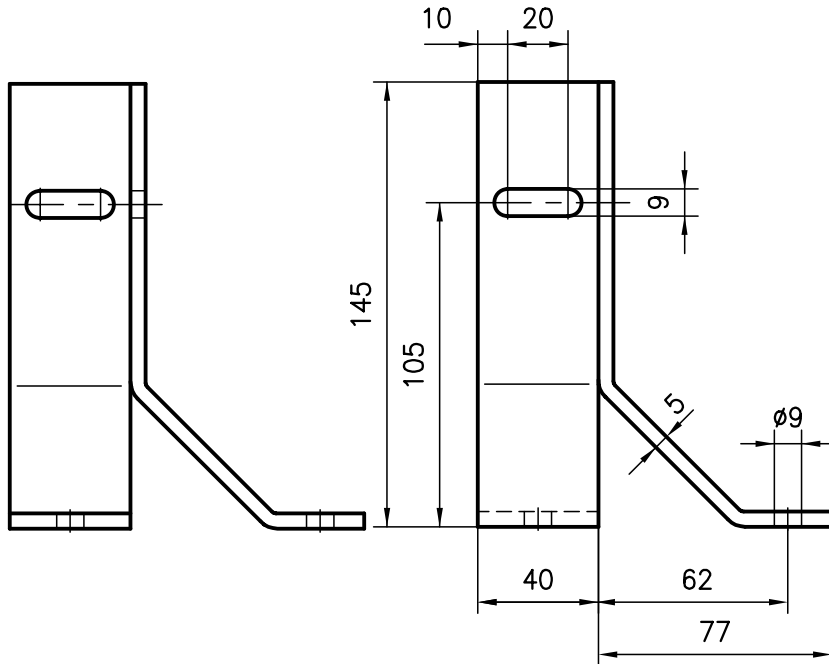

### Application

An advance on the normal floor bolting bracket, with the added advantage that it can be used together with large levelling feet ( $\varnothing 90$ ). The double bolting bracket also secures the supporting extrusions in two directions.

### Specification

Steel, powder-coated in black

### Fixing kit\*

2 screws  
2 threaded plates  
2 washers

Order data	Order number
------------	--------------

Double bolting bracket	A47-20(-S)*
------------------------	-------------

\*Fixing kit: add -S to the order number



## Single bolting bracket

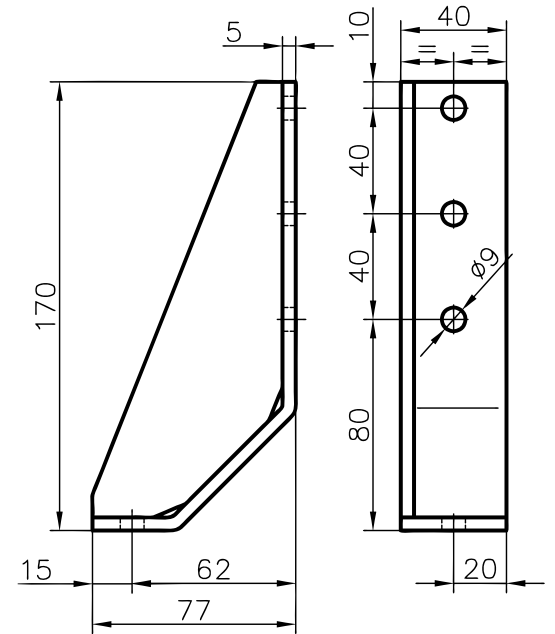

### Application

Same as the aluminium floor bolting bracket with the added advantage that it can be used together with large levelling feet  $\varnothing 90$ .

### Specification

Steel, powder-coated in black

### Fixing kit\*

2 screws  
2 threaded plates  
2 washers

Order data	Order number
------------	--------------

Single bolting bracket	A47-22(-S)*
------------------------	-------------

\*Fixing kit: add -S to the order number

## Leg bolt-down socket

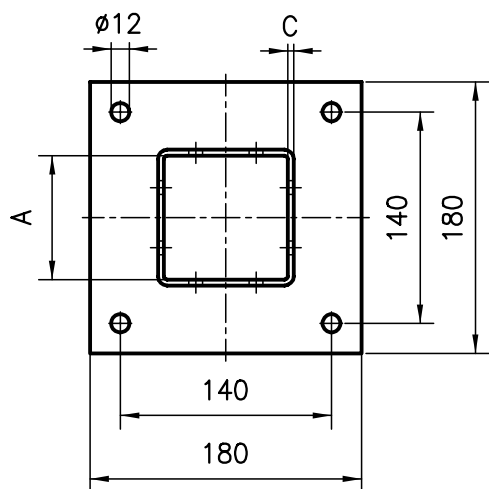
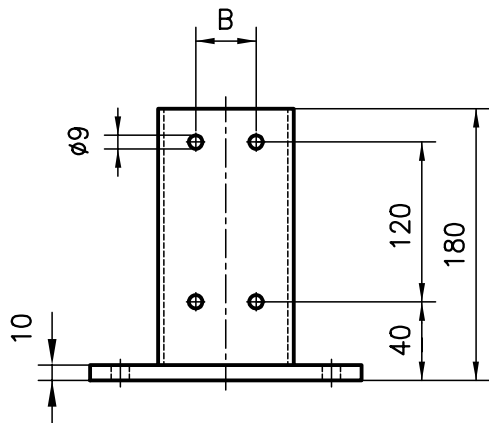

### Application

The bolt-down socket is used in applications where the legs have to be very firmly secured to the ground. The extrusion can be adjusted easily within the guide socket and can be secured in place using the fixing kit included. The bolt-down socket should be chosen, from the three available, to suit the space available.

### Specification

Steel, powder-coated in black

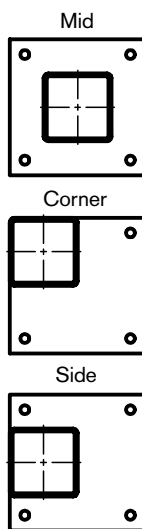
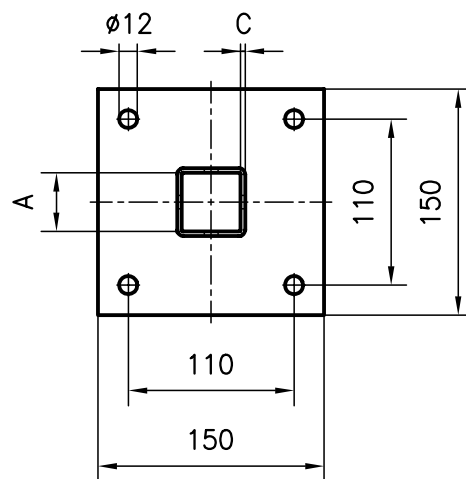
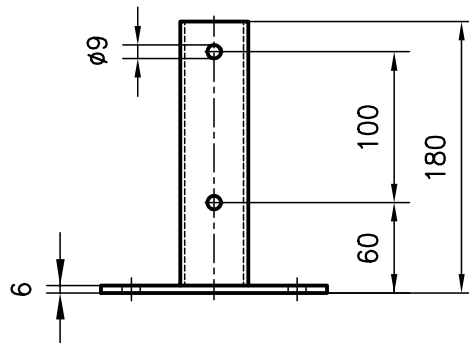

### Fixing kit\*

(applies to all types)

8 cylinder screws, 8 threaded plates

8 washers



### Fixing kit\*

4 cylinder screws, 4 threaded plates,

4 washers

Order data				Order number	Order data				Order number
Extrusion	A	B	C	Type	Extrusion	A	B	C	Type
80x80	82	40	4	Middle	40x40	41	-	2	Middle
				Corner					Corner
				Side					Side
*Fixing kit				C47-36-S	*Fixing kit				C47-32-S
					50x50	52	-	4	Middle
									Corner
									Side
					*Fixing kit				A47-32-S

## Castors

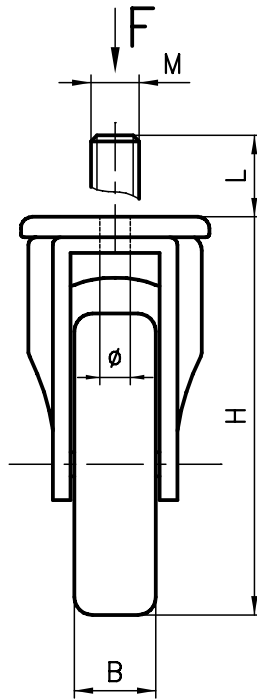
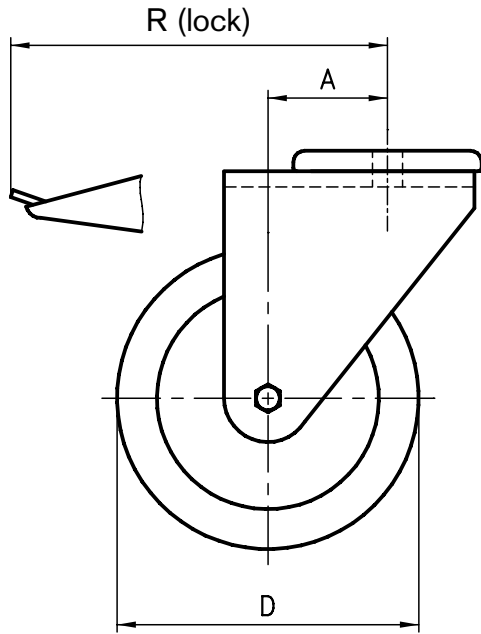

## Non-swivel castors

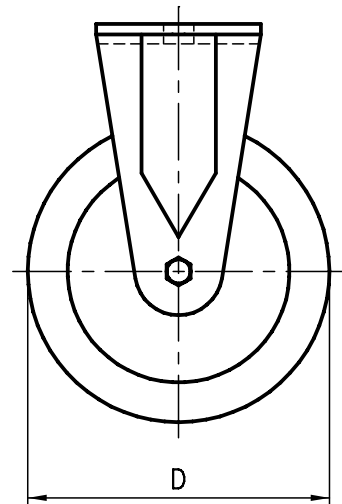

### Application

Can be used in any application where mobility is required. There are four diameters of wheels available (with or without locks) depending on the load capacity required. Swivel and non-swivel castors have the same load capacity. (F) The castors can be simply attached to the extrusions either with an M10 bolt or by means of an M16 / 14x25 threaded stud.

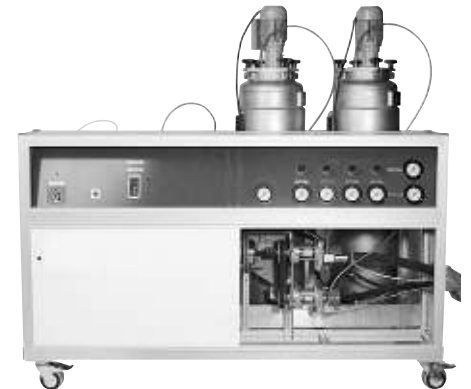

### Specification

Fork: Steel, Ball bearing  
 Wheel: Rubber tyre, Ball bearing

	Order data			Order number					
	D	B	H	A	R	Ø / MxL	F	no lock	with lock
Castor	50	19	70	25	72	Ø 10.3	400 N	B48-50	B49-50
Castor	50	19	70	25	72	M14x25	400 N	B48-54	B49-54
Castor	75	22	97	30	85	Ø 10.3	700 N	B48-75	B49-75
Castor	75	22	97	30	85	M14x25	700 N	B48-74	B49-74
Castor	100	32	132	42	118	Ø 10.3	800 N	B48-100	B49-100
Castor	100	32	132	42	118	M16x25	800 N	A48-100	A49-100
Castor	125	32	158	42	118	Ø 10.3	1000 N	B48-125	B49-125
Castor	125	32	158	42	118	M16x25	1000 N	A48-125	A49-125

	Order data			Order number	
	D	B	H	Ø / MxL	
Non-swivel castors	75	22	97	Ø 10.3	B48-77
Non-swivel castors	75	22	97	M14x25	B48-78
Non-swivel castors	100	25	132	Ø 10.3	B48-107
Non-swivel castors	100	25	132	M16x25	A48-108
Non-swivel castors	125	32	158	Ø 10.3	B48-127
Non-swivel castors	125	32	158	M16x25	A48-128

For load of >800N we recommend castors with PO-wheels.

Castors with PO-Wheels and other sizes, heavy duty and anti-static castors are available on request.

## Rollers

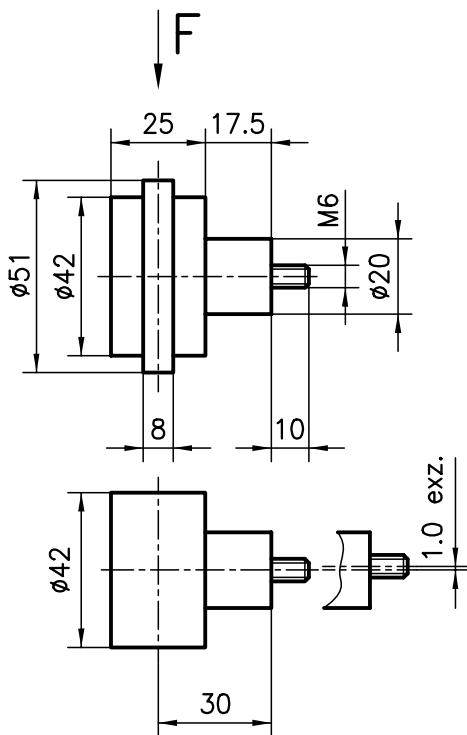

### Application

This roller is suitable for heavy sliding doors, as a wheel for workpiece holders or for general structures which have to move freely.

Insert the guide flange into the extrusion slot. Fit the flat roller onto the other side. This creates the perfect trolley/rail combination independent of the extrusion tolerance.

### Specification

Plastic roller, ball bearing mounted, steel spacer, gun-metal finish  
Radial load  
 $F = 500 \text{ N}$

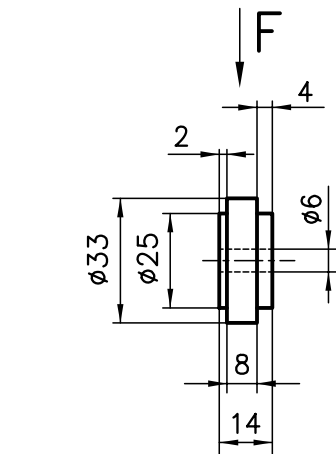

### Application

This ball bearing-mounted roller is mainly used in an assembly with the trolley extrusion, although it can also be attached directly to any extrusion.

### Specification

PA 6 black  
2 deep groove ball bearings with cover disks  
 $F = 150 \text{ N}$

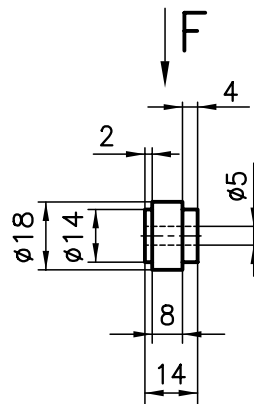

### Application

Same as the PA roller, except that it fits small trolley extrusions. This low-cost roller is ideal for smaller loads. It is not fitted with a ball bearing rollers.

### Specification

POM black  
 $F = 75 \text{ N}$

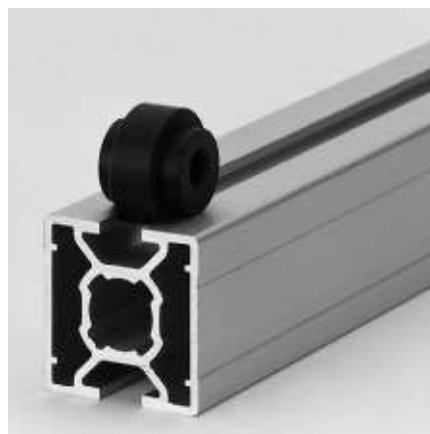
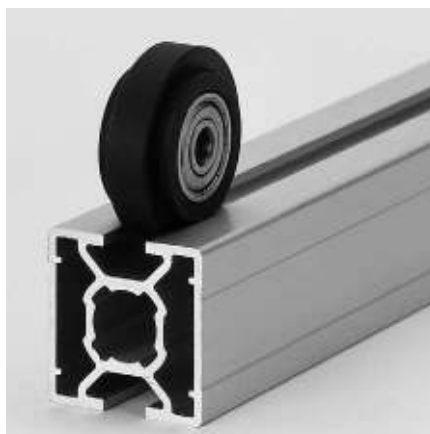

### Order data

### Order number

	Centric	Eccentric
Roller with guide flange	C48-00	C48-01
Roller without guide flange	C48-10	C48-11

### Order data

### Order number

Roller PA	B48-05
-----------	--------

### Order data

### Order number

Roller POM	B48-03
------------	--------

## Roller-mounted support

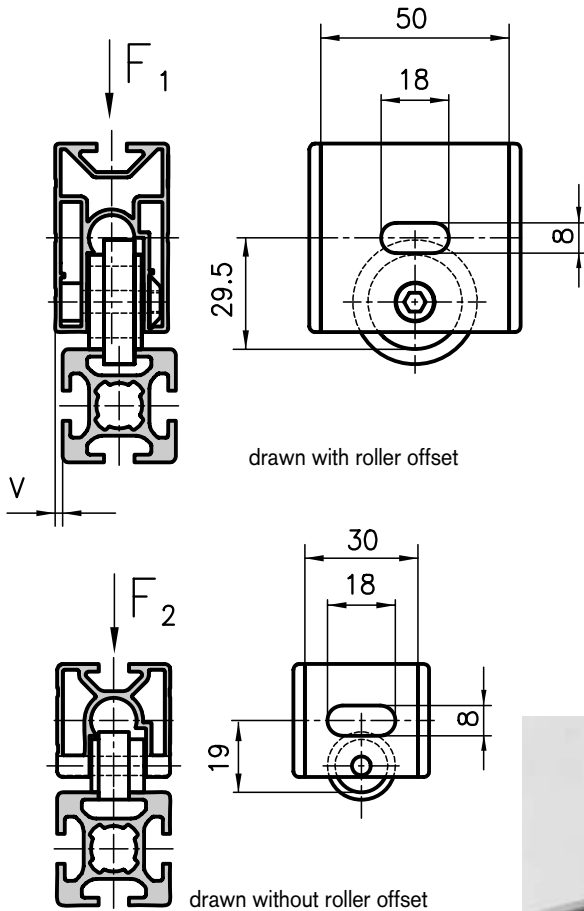

### Application

Single trolleys can be combined with any other extrusions. Special trolleys or guides for moving components can be built very quickly. **Refer to page 83 for dimensioned drawings of the extrusions.**

### Parts supplied

Aluminium extrusion fitted with 1 roller and 2 cover caps.  
 $F_1 = 150 \text{ N}$  |  $F_2 = 75 \text{ N}$

## Double trolley

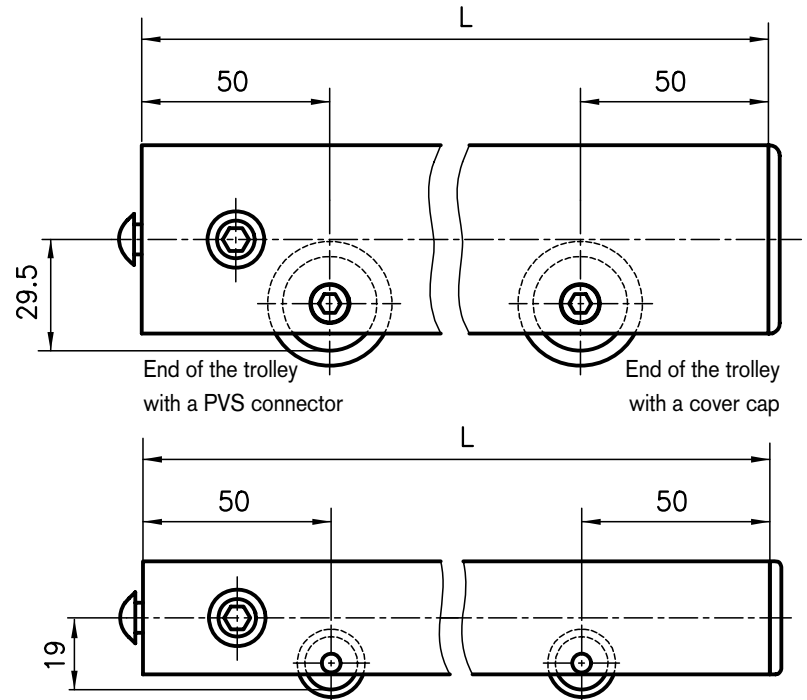

### Application

A wide range of different applications is possible with the double trolley. It provides a simple and mechanically reliable way of creating equipment chassis, sliding doors, lifting devices etc. Any lengths of extrusion can be used. However, rollers for small trolleys should not be spaced any more than 700 mm apart, and for large trolleys the spaces between rollers should not exceed 1000 mm.

Trolleys are also available with more than 2 rollers.

### Parts supplied

Aluminium extrusion fitted with > 2 rollers. PVS connector and/or cover caps fitted. Load, see rollers.

Order data	Order number	
	v = 0 mm	v = 2 mm
Large roller-mounted support	B37-50	B37-51
Small roller-mounted support	B37-30	B37-31

Order data		Order number	
		v = 0 mm	v = 2 mm
Large double truck	L= ... with cover caps	B37-52-02-02/...	B37-53-02-02/...
Large double truck	L= ... with PVS connector	B37-52-10-10/...	B37-53-10-10/...
Small double truck	L=... with cover caps	B37-32-02-02/...	B37-33-02-02/...
Small double truck	L=... with PVS connector	B37-32-10-10/...	B37-33-10-10/...

## Plastic slide extrusions

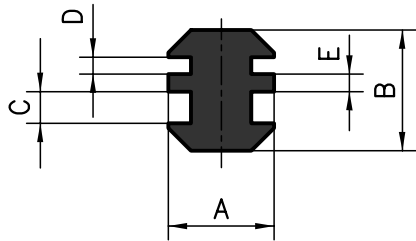

**Specification**  
 Black PE  
 Sliding friction coefficient: 0,2  
 Heat resistance to DIN 53461:  
 -250 °C to 100 °C  
 Indentation hardness to DIN 53456:  
 39N/mm<sup>2</sup>

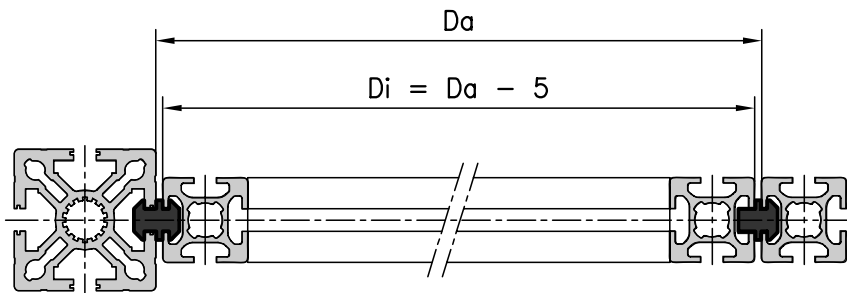

### Measurement data

Extrusion base	A	B	C	D	E
50/40	21	21	4.1	4.1	2.3
50/40-30/20	14	16	4.1	2.2	2.3
30/20	14	14	2.2	2.2	2.3



### Application

Ideal for any shape of slide guide, for instance for sliding doors or drawer runners. Simply push the slide extrusion into the aluminium extrusion slots – you can create a perfect, hard-wearing guide as easily as that.

Make the inner frame 5 mm smaller than the inner width of the outer frame. It is also ideal for static extrusion assemblies.

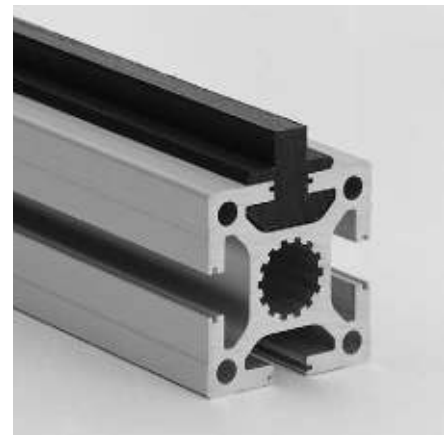
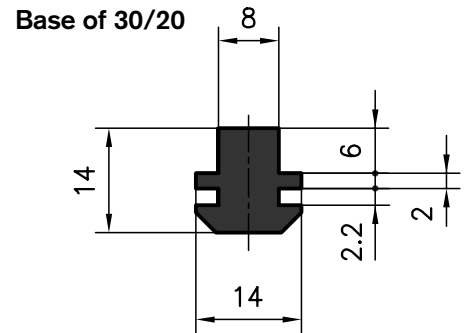
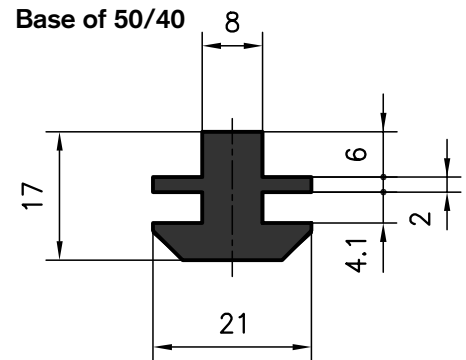

### Order data      Order number

<b>Plastic slide extrusion</b>	<b>Base of 50 / 40</b>
Standard length 5000 mm	A39-00-00/5000
Cut to length	A39-00-02-02/ ...
<b>Plastic slide extrusion</b>	<b>Base of 50 / 40 - 30 / 20</b>
Standard length 5000 mm	AB39-00-00/5000
Cut to length	AB39-00-02-02/ ...
<b>Plastic slide extrusion</b>	<b>Base of 30 / 20</b>
Standard length 5000 mm	B39-00-00/5000
Cut to length	B39-00-02-02/ ...

### Order data      Order number

<b>Plastic slide extrusion</b>	<b>Base of 50/40</b>
Standard length 5000 mm	A39-05-00/5000
Cut to length	A39-05-02-02/...
<b>Plastic slide extrusion</b>	<b>Bases of 30/20</b>
Standard length 5000 mm	B39-05-00/5000
Cut to length	B39-05-02-02/...

**Base of 50/40**

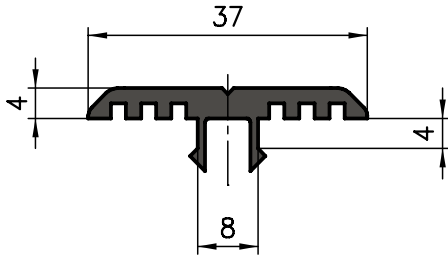

**Base of 30**

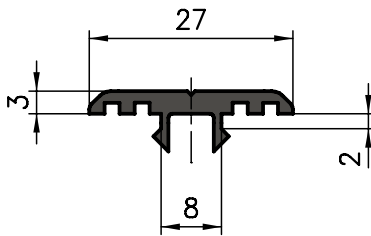

**Application**

This slide extrusion is mounted on the extrusion, acting as a sliding carrier for goods or pallets. The slide extrusion can also be used as a protective strip.

**Specification**

PP, black

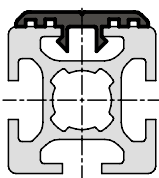

Order data	Order number
Plastic slide extrusion	Base of 50/40
Standard length 5000 mm	AC39-20-00/5000
Cut to length	AC39-20-02-02/...
Plastic slide extrusion	Base of 30
Standard length 5000 mm	B39-20-00/5000
Cut to length	B39-20-02-02/...

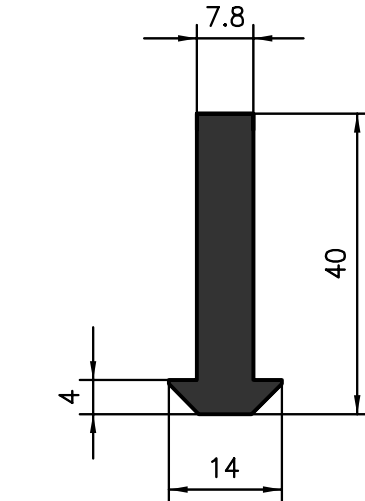

**Application**

For single sliding doors, suspended fittings, cable supports and many other uses. Fits all standard KANYA extrusions.

**Specification**

PE, black

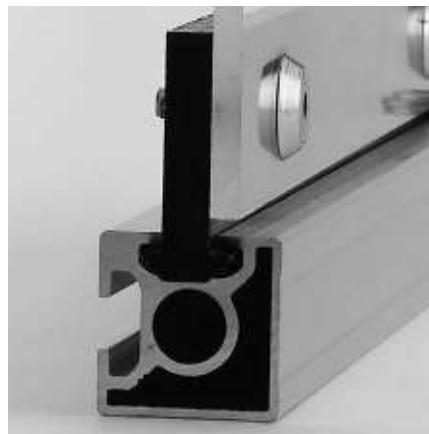

Order data	Order number
Plastic slide extrusion	Basis 50/40/30/20
Standard length 5000 mm	A69-0-00/5000
Plastic slide extrusion	
Cut to length	A69-0-02-02/...

**Sliding hook**

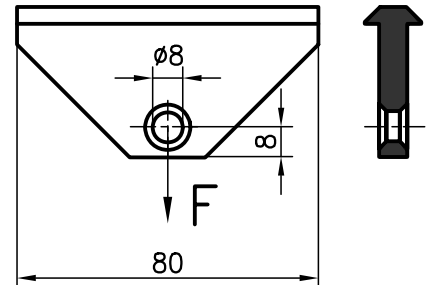

**Application**

The sliding hook is ideally suited for suspended tool applications or as a cable guide. It is simply pressed into the extrusion slot and moves freely. Other lengths of multiple-hole versions are available on request.

**Specification:**

Slider: PE, black  
 made from a plastic slide extrusion, A69-0-00  
 load-bearing capacity: F = 300 N  
 Spring hook: chromium-plated steel

Order data	Order number
No spring hook	A69-00
With a spring hook	A69-01

## Cable ducts

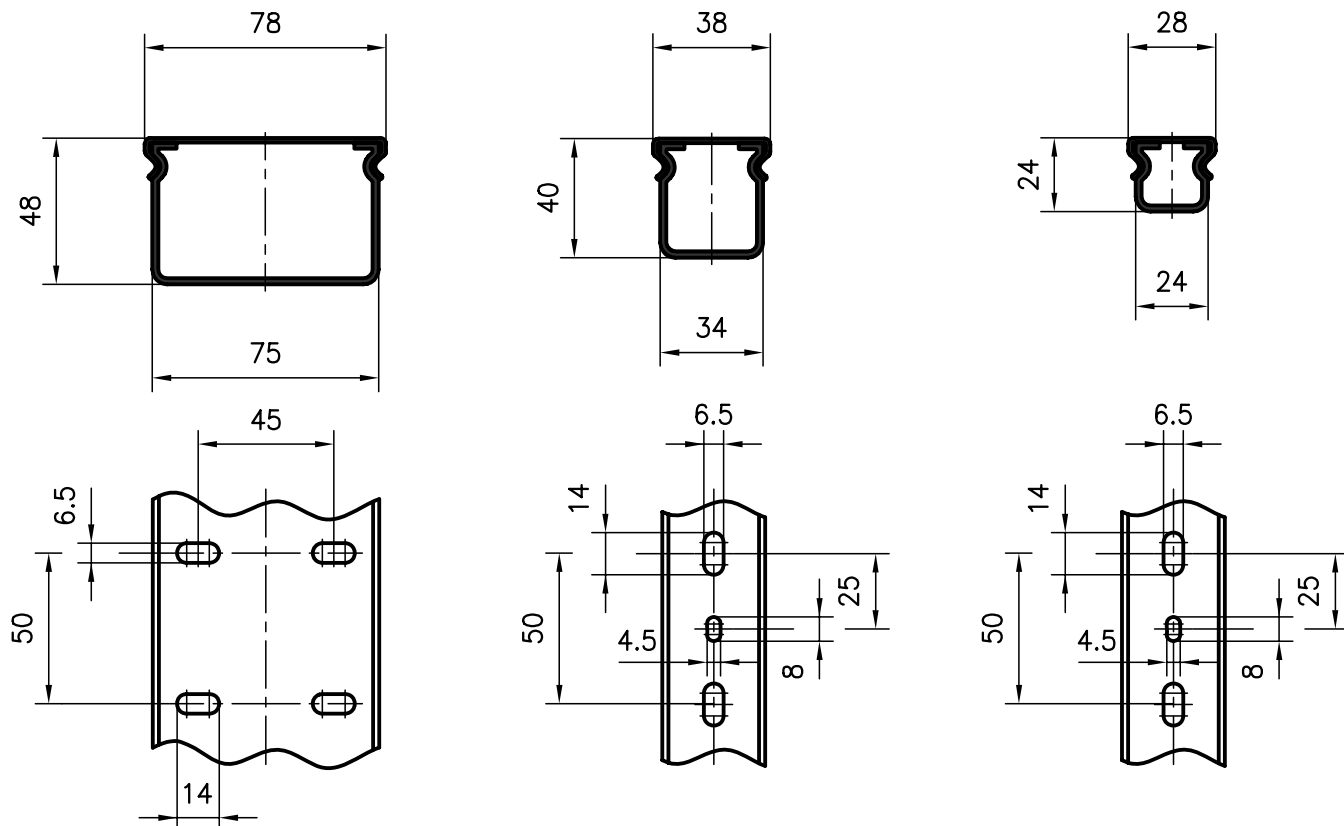

### Application

The cable ducts are placed directly onto the extrusions and are secured using either the retaining clips (see page 125) or extrusion nuts available. The duct is easy to open or close any time as it is fitted with a press-on cover. The slotted sides enable cables to be fed in and out at any point.

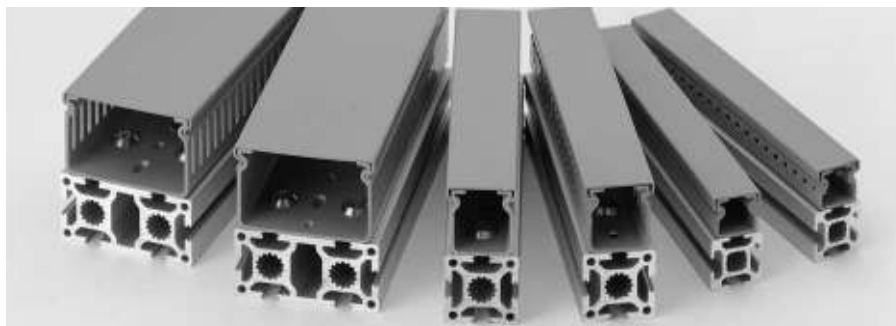

### Specification

UPVC, light grey

(Standard lengths: solid cable duct 5000 mm, slotted cable duct 2000 mm)

Order data		Order number	
Cable ducts		closed	slotted
75 mm wide cable duct	Standard lengths Cut to length	A38-00-00/5000 A38-00-02/...	A38-01-00/2000 A38-01-02/...
34 mm wide cable duct	Standard lengths Cut to length	C38-00-00/5000 C38-00-02/...	C38-01-00/2000 C38-01-02/...
24 mm wide cable duct	Standard lengths Cut to length	B38-00-00/5000 B38-00-02/...	B38-01-00/2000 B38-01-02/...

## Retaining clips

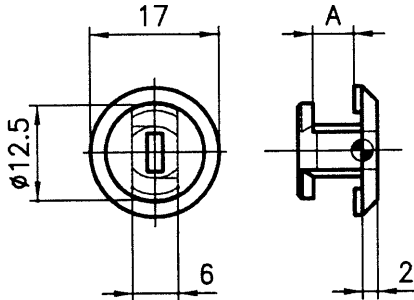

### Application

The quarter turn retaining clips allow the easy fixing of either cable ducts or thin sheet material onto the extrusions Base 50, 40 and 30.

### Specification

PA-GF, black



Order data	Order number
------------	--------------

Retaining clips A = 5.5	AC38-20
Retaining clips A = 3.5	B38-20

## «Velcro» Cable ties

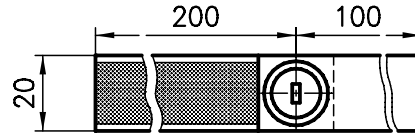

## tie wrap «base»

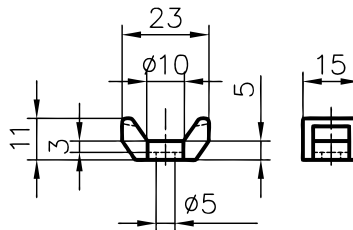

### Application

This universal cable tie is made from a combination of Velcro material and a retaining clip. The Velcro can be cut to length with scissors. The quarter turn retaining the clip ensures easy fixing to the extrusions Base 50, 40 and 30.

On the tie-wrap-base you can fix standard tie wraps. Fix with a M5-screw

### Specification

Clips: glass-filled Polyamide (PA-GF) black  
 Ribbon: Velcro black  
 Tie wrap Base: PA black



Order data	Order number
------------	--------------

Cable ties «Velcro»	extrusion base 50/40 30
	B50-50 B50-53
Tie wrap «Base»	50/40/30/20
	B50-55

## Installation rings

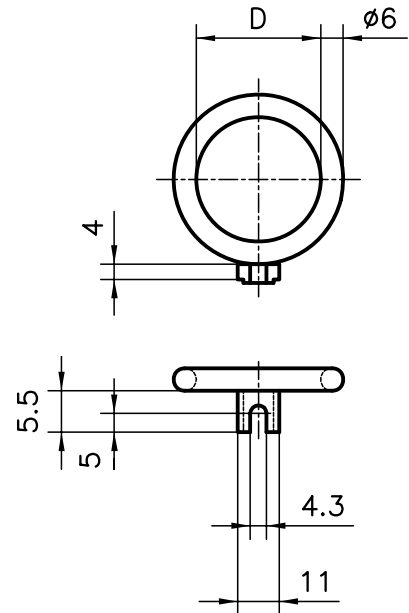

### Application

Installation rings are ideal for holding cables and pipes in place, and as tool holders. The rings can be fixed into the 8 mm extrusion slot using an M4 screw. They are held in place without twisting in the slot. There are two different diameters of rings available to cover the various possible applications.

### Specification

PA-GF, black



Order data	Order number
------------	--------------

Installation ring	D	
	Ø 18	B50-20
Installation ring	Ø 33	B50-30

## End caps



### Application

End caps are used as covers for the exposed ends of extrusions. They prevent injury from the sharp edges of the extrusions. Special centring elements make them easy to fix and prevent the caps from twisting. Two end caps can be used together to cap off larger extrusions, eg extrusion 80x120 uses two 40x120 end caps.

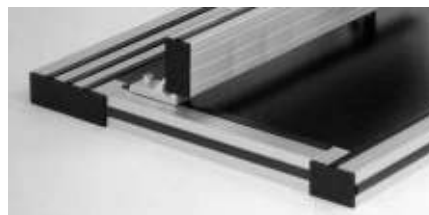

### Specification

PA-GF, black

Extrusion	Cap height
Base of 50 / 40	4 mm
Base of 30 / 20	3 mm

Order data	Order number
End caps 50x50	A40-10
End caps 50x50	A40-19 (extr. A19-1)
End caps 50x45°	A40-80
End caps 50x100	A40-20
End caps 50x150	A40-30
End caps 100x100	A40-50
End caps 40x40	C40-10
End caps 40x40	C40-83 (extr. C03-8)
End caps 40x45°	C40-80 (extr. C02-8)
End caps 40x45°	C40-84 (extr. CE4-4)
End caps 40x80	C40-30
End caps 40x120	C40-90
End caps 80x80	C40-20 (extr. C01-2)
End caps 80x80	C40-40

Order data	Order number
End caps 30x30	B40-30
End caps 30x30	B40-10 (extr. B01-1)
End caps 30x30	B40-80 (extr. B01-8)
End caps 30x30°	B40-33
End caps 30x45°	B40-45
End caps 30x60°	B40-66
End caps 30x50	B40-90
End caps 30x60	B40-60
End caps 30x95	B40-50
End caps 30x100	B40-20
End caps 30x120°	B40-40
End caps 30 8-Kt.	B40-15
End caps 60x60	B40-65
End caps 20x20	D40-30
End caps 20x20	D40-80 (extr. D03-8)
End caps 20x47	D40-20
End caps 20x40	D40-60
End caps 20x150	D40-19
End caps 20 oct.	D40-10

## Aluminium filler strip

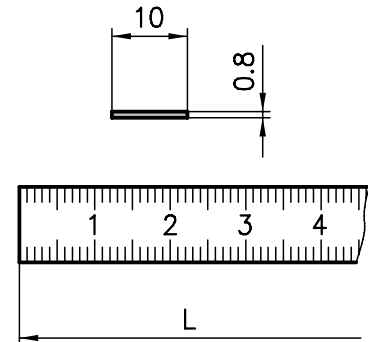

### Application

These aluminium strips can be used to blank off the longitudinal slots on all extrusions with a base of 40 and 50. They are extremely easy to cut to length using tin snips or shears. They can be supplied at short notice in any RAL colour in addition to the standard colours (natural anodised or black powder coated).

### Specification

Aluminium 0.8x 10  
anodised with millimeter scale

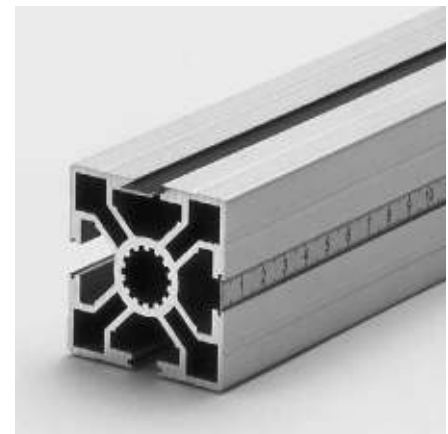

Order data	Order number
<b>Filler strip</b>	<b>black</b>
L = 1000 mm	A39-10
L = 2000 mm	A39-12
<b>Filler strip</b>	<b>anodised mm-scale</b>
L = 1000 mm	A39-15 A39-16
L = 2000 mm	A39-17 A39-18

## PVC filler strips

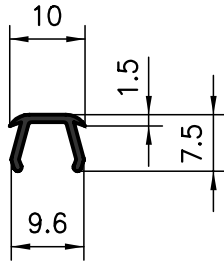

### Application

The PVC filler strip can be clipped into the 8 mm longitudinal slot on any extrusion after assembly and is available in grey or black.

### Specification

Grey or black PVC

## Channel reducing strip

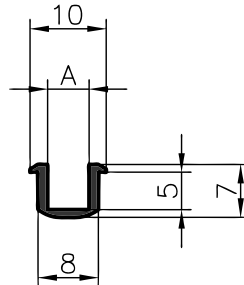

### Application

Channel reducing strips are used if 3, 4 or 5 mm panels are to be inserted into the extrusion slots.

### Specification

Grey PVC for panels of 3, 4 or 5 mm in thickness

Plate insertion depth: 4 mm

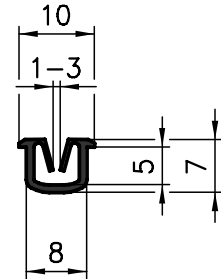

### Application

For thin sheets eg expanded metal, steel sheets, etc.

### Specification

Grey PVC for panels up to 3 mm

Plate insertion depth: 4 mm

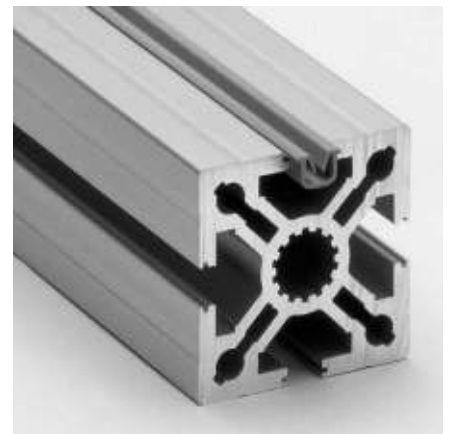
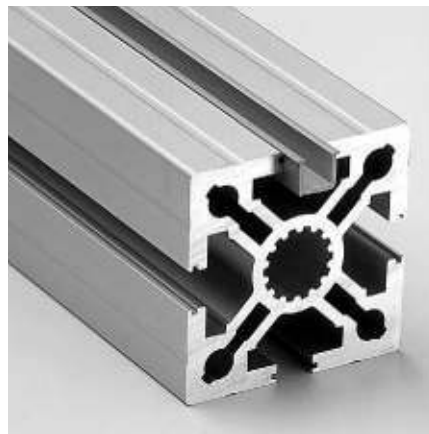

Order data	Order number
<b>Filler strips</b>	<b>grey</b>
Standard length 5000mm	A39-25-00/5000
Cut to length	A39-25-02-02/...
<b>Filler strips</b>	<b>black</b>
Standard length 5000mm	A39-26-00/5000
Cut to length	A39-26-02-02/...

Order data	Order number
<b>Channel reducing strip</b>	<b>A = 3,5 mm</b>
Standard length 5000 mm	A39-33-00/5000
Cut to length	A39-33-02-02/...
<b>Channel reducing strip</b>	<b>A = 4,5 mm</b>
Standard length 5000 mm	A39-32-00/5000
Cut to length	A39-32-02-02/...
<b>Channel reducing strip</b>	<b>A = 5,5 mm</b>
Standard length 5000 mm	A39-34-00/5000
Cut to length	A39-34-02-02/...

Order data	Order number
<b>Channel reducing strip</b>	
Standard length 5000 mm	A39-31-00/5000
Cut to length	A39-31-02-02/...

## Channel reducing strips and filler strips

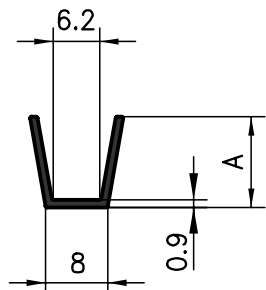

### Application

To hold panels which are 6 mm thickness. They can also be inverted to blank off the slots on triple channel extrusions.

### Specification

Grey PVC for panels of 6 mm in thickness  
Panel insertion depth: 11 mm



## H-strip

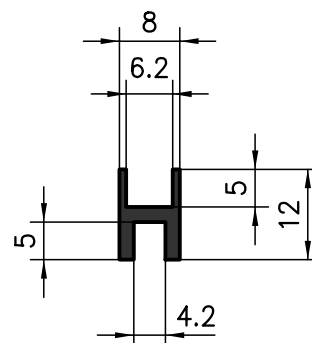

### Application

Used in combination with the B39-55 channel reducing strip, this H-strip allows lift-on or lift-off panels to be inserted or removed.

Bottom: B39-35

Top: B39-55

### Specification

Grey PVC for panels of 4 or 6 mm in thickness

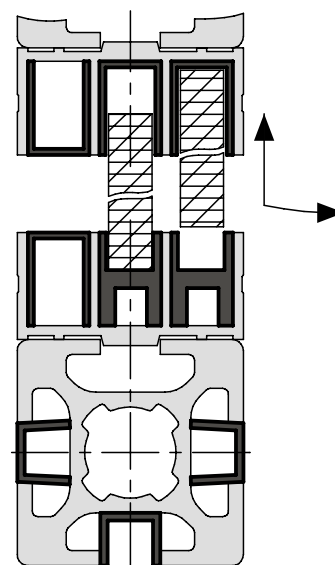
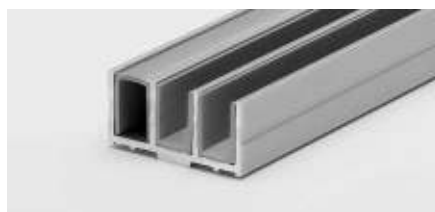

Order data	Order number
------------	--------------

<b>Channel reducing strip</b>	<b>extrusions 50</b>
A = 14.5 mm	
Standard length 5000 mm	A39-50-00/5000
Cut to length	A39-50-02-02/...

<b>Channel reducing strip</b>	<b>extrusions 40</b>
A = 10 mm	
Standard length 5000 mm	C39-50-00/5000
Cut to length	C39-50-02-02/...

<b>Channel reducing strip</b>	<b>extrusions 30</b>
A = 6.5 mm	
Standard length 5000 mm	B39-50-00/5000
Cut to length	B39-50-02-02/...

<b>Channel reducing strip</b>	<b>extrusions B05-1</b>
A = 12 mm	
Standard length 5000 mm	B39-55-00/5000
Cut to length	B39-55-02-02/...

Order data	Order number
------------	--------------

<b>H-strip</b>	<b>extrusions B05-1</b>
Standard length 5000 mm	B39-35-00/5000
Cut to length	B39-35-02-02/...

## Supporting extrusion

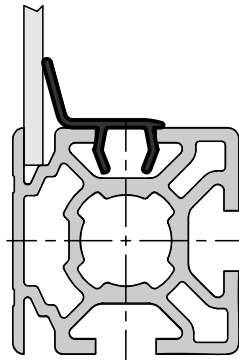
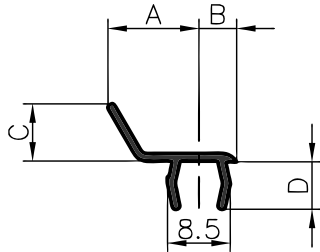

### Application

The supporting extrusion has two functions:

1. It gives optimum support (pressure) to thin panels which are inserted into the narrow slots.
2. At the same time it also covers the extrusion connector slots.

### Specification

Grey PVC

#### Measurement data

Extrusion base	A	B	C	D
30	13	5	8	6
40	15	7	10	9

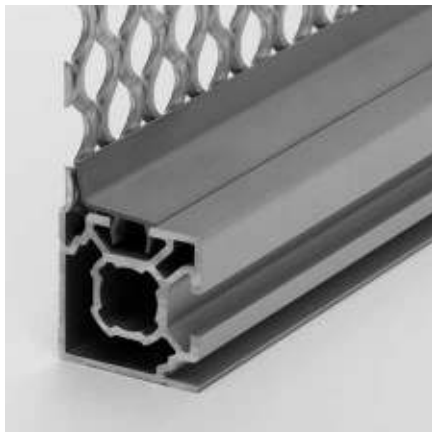

Order data	Order number
Clamping extrusion	
Standard length 5000 mm	B39-25-00/5000
Cut to length	B39-25-02-02/...

Order data	Order number
Supporting extrusion	
Standard length 5000 mm	C39-25-00/5000
Cut to length	C39-25-02-02/...

## Wedge extrusion

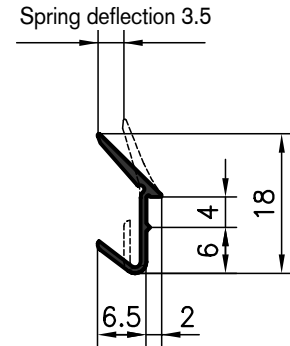

### Application

The wedge extrusion can be pressed into the slot on extrusions with a base of 40 or 50 mm. The force holds the panels tightly in place, however thick they are.

### Specification

Grey PVC

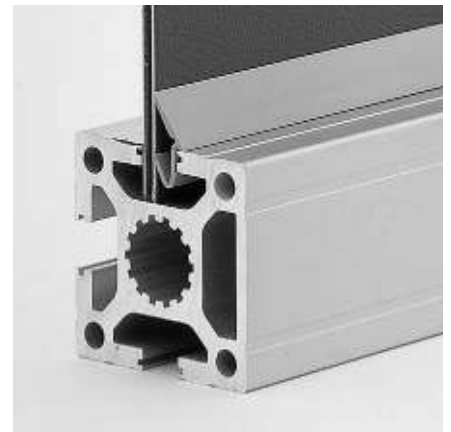

Order data	Order number
Wedge extrusion	
Standard length 5000 mm	C39-45-00/5000
Cut to length	C39-45-02-02/...

### Safety-edge extrusion

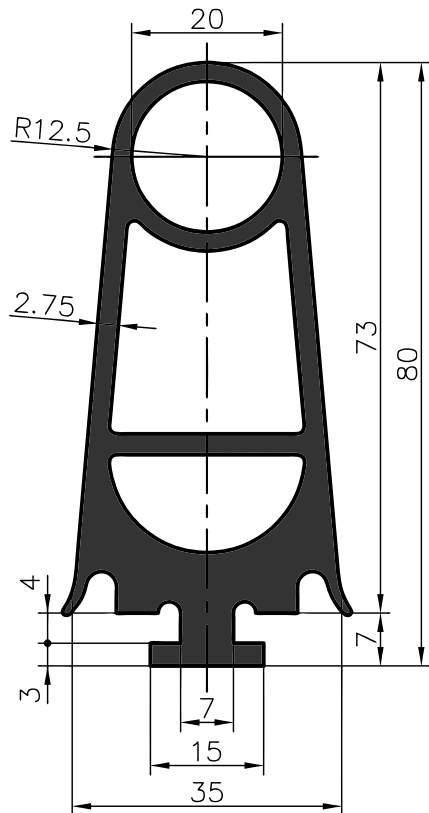

#### Application

Mainly used as a personal safety-extrusion on automatic sliding doors and everywhere there is danger of crushing parts. It fits to the KANYA-extrusions of the base 50 + 40.

#### Specification

EPDM caoutchouc black

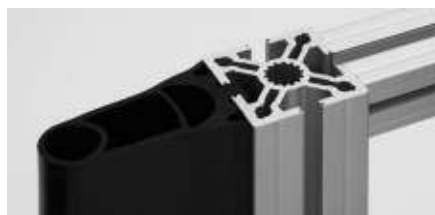

Order data	Order number
------------	--------------

Safety-edge extrusion	C39-90
Standard length 2000 mm	

### Semi-circular sealing strip

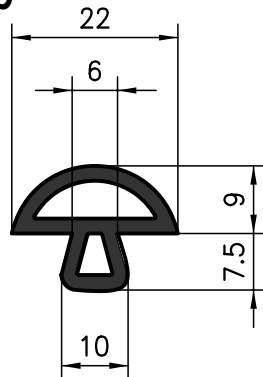

#### Application

Sealing strip for clean room technology and many other applications. Fits all standard KANYA extrusions.

#### Specification

Black neoprene rubber, oil-resistant.

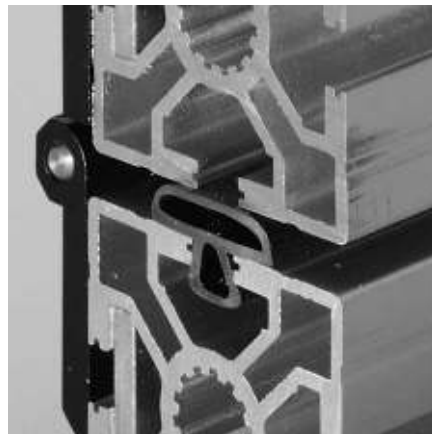

Order data	Order number
------------	--------------

Semi-circular sealing strip	A39-85-00/5000
Standard length 5000 mm	
Cut to length	A39-85-02-02/...

### Door sealing strip

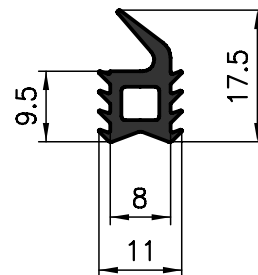

#### Application

Used to seal doors. Fits in all KANYA standard extrusions base 40 + 50 – as does the semi-circular sealing strip.

#### Specification

Black soft PVC, oil-resistant, 57 Shore A



Order data	Order number
------------	--------------

Door sealing strip	A39-88-00/5000
Standard length 5000 mm	
Cut to length	A39-88-02-02/...

## U-sealing strip

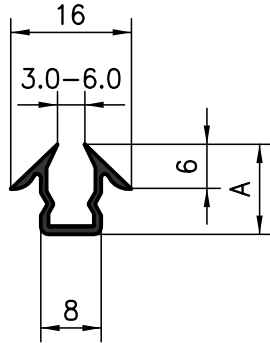

### Application

This sealing strip can be inserted into the 8 mm slots on any extrusions and is suitable for panels measuring between 3 and 6 mm in thickness.

### Specification

Black neoprene rubber, oil-resistant.

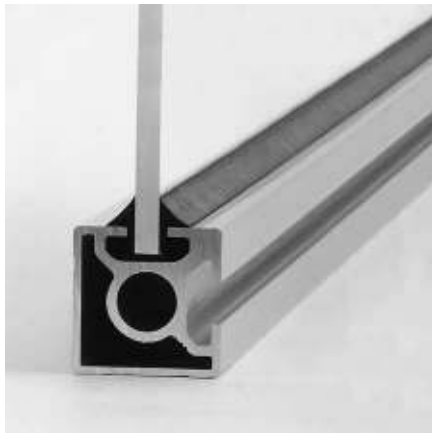

Order data	Order number
<b>U-sealing strip, A = 12 mm</b>	<b>40/30 mm base</b>
Standard length 5000 mm	B39-65-00/5000
Cut to length	B39-65-02-02/...
<b>U-sealing strip, A = 18 mm</b>	<b>50 mm base</b>
Standard length 5000 mm	A39-65-00/5000
Cut to length	A39-65-02-02/...

## Grid extrusion

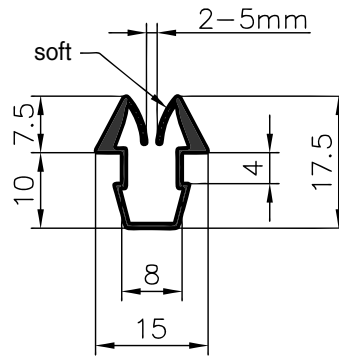

### Application

Mainly used for holding steel-wire-mesh. The soft lips insulate the vibration and compensates the different thicknesses. It's qualified for panels with 2-5 mm thickness.

The grid extrusion fits into the base 50 and 40.

### Specification

Hard- (soft) PVC, black

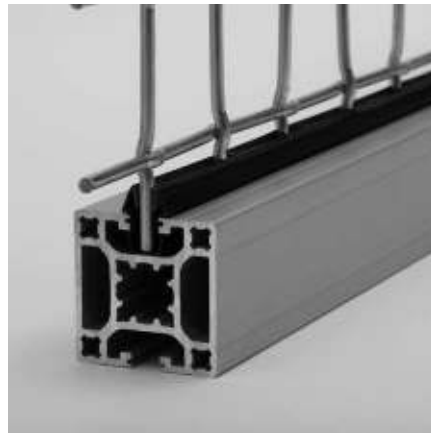

Order data	Order number
<b>Grid extrusion</b>	
Standard length 5000 mm	C39-70-00/5000
Cut to length	C39-70-02-02/...

## Clamping sealing strip

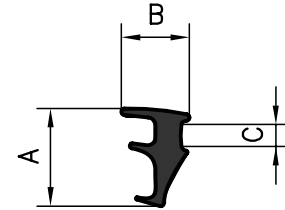

### Application

This sealing strip is used to stabilise and seal panels. It is fitted after the panels are inserted.

### Specification

Black neoprene rubber, oil-resistant.

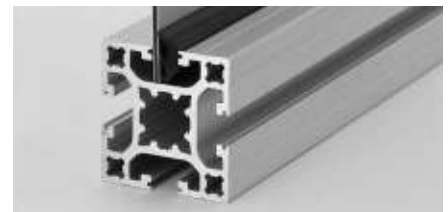

### Measurement data

	A	B	C
Panels 1-3 mm thick	13	9	4
Panels 3-4 mm thick	10.5	7.5	3
Panels 5-6 mm thick	10.5	6.2	3

### Order data

#### Clamping sealing strip

Order data	Order number
Panels 1-3 mm thick	
Standard length 5000 mm	A39-80-00/5000
Cut to length	A39-80-02-02/...
Panels 3-4 mm thick	
Standard length 5000 mm	A39-81-00/5000
Cut to length	A39-81-02-02/...
Panels 5-6 mm thick	
Standard length 5000 mm	A39-83-00/5000
Cut to length	A39-83-02-02/...

## Enclosure panels

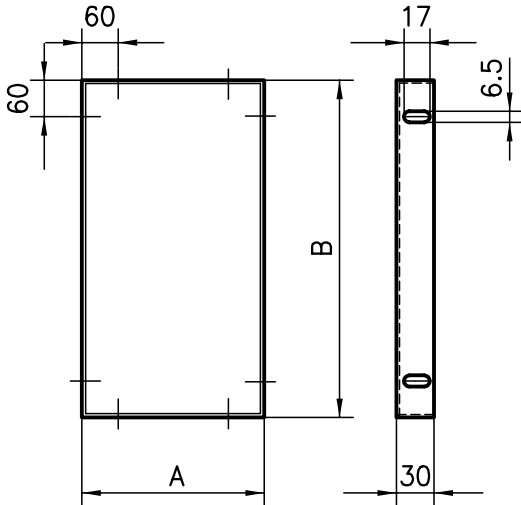

### Application

These panels are used to strengthen and enclose structures which are subject to heavy loads. Sheet steel enclosure panels serve two functions; firstly, they ensure safety and secondly, they enclose the machines attractively.

### Specification

1.25 mm sheet steel, powder coated, maximum size: 900 x 1500 mm  
 Colour: RAL shade requested by the customer  
 Weight: 11.2 kg/m<sup>2</sup>



**Order data**                      **Order number**

Enclosure panel, state colour    B53-00 A x B

## Aluminium sheets

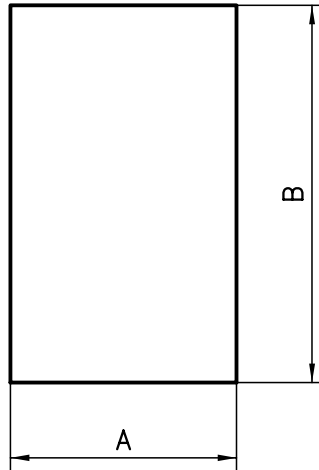

### Application

All types of enclosures.

### Specification

**Al-sheet** 1.5 and 3.0 mm  
 Anodised in natural colour and one side with a protection film  
 Maximum size: 1000 x 2000mm  
**Steel-sheet** 1.25 mm zinc-coated  
 Maximum size: 1000 x 2000 mm  
 Other dimensions or powder coated sheets are available on request  
 Weight: Al 1.5 mm: 4.05 kg/m<sup>2</sup>  
           Al 3.0 mm: 8.10 kg/m<sup>2</sup>  
           St 1.25 mm: 10.0 kg/m<sup>2</sup>



**Order data**                      **Order number**

Aluminium sheet, 1.5 mm        A53-15 A x B  
 Aluminium sheet, 3 mm        A53-30 A x B  
 Steel sheet 1.25 mm            A53-51 A x B

## Expanded metal

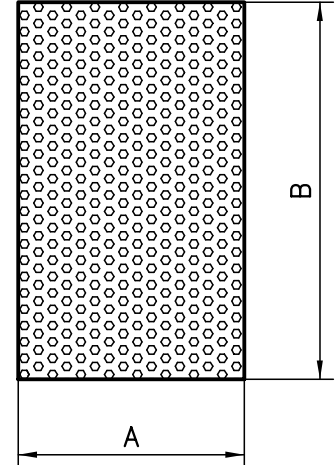

### Application

The panel for designers with taste – light and attractive, but nonetheless sturdy. Can be used for virtually any purpose.

### Specification

Aluminium 2 mm, raw  
 Maximum size: 1000 x 2000 mm  
 Weight: 2.0 kg/m<sup>2</sup>

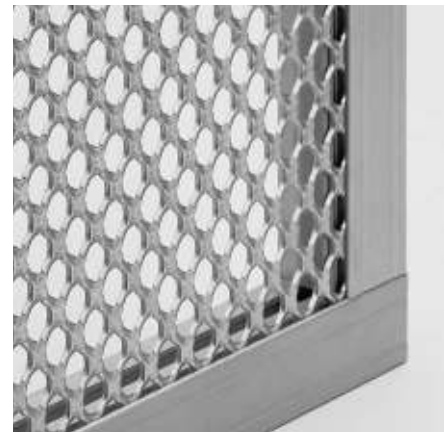

**Order data**                      **Order number**

Expanded metal                    A54-20 A x B

## Composite panels

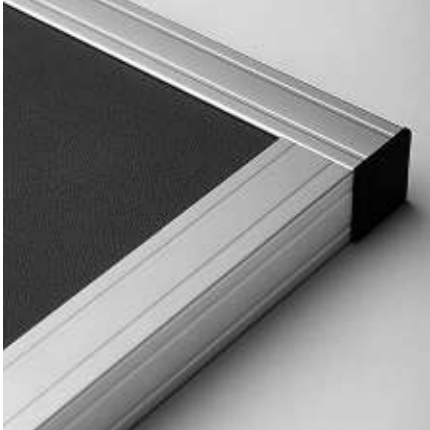

### Application

Intrinsically high strength enclosure panels. The thicknesses of the panels fit the narrow slots of the different 30 mm base extrusions, guaranteeing a tidy finish.

### «DIBOND» specification

Composite panel lined on either side with 0.3 mm thick aluminium sheets. Stove-enamelled on either side.

Thickness: 2.0 mm

Colour: aluminium metallic finish

Thickness: 3.0 mm

Colour: white, similar to RAL 9016  
blue, similar to RAL 5002  
black, similar to RAL 9005

Size: max. 1250 x 2500 mm

Weight: 2.0 mm: 2.9 kg/m<sup>2</sup>

3.0 mm: 3.8 kg/m<sup>2</sup>

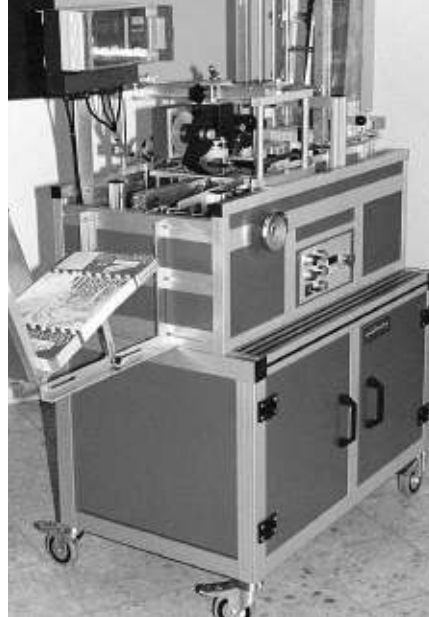

### «ALUCOBOND» specification

Composite panel lined on either side with 0.5 mm thick aluminium sheets.

Thickness: 4.0 mm

Surface: anodised in a natural colour on either side

Thickness: 4.0 mm

Surface: rolled matt (natural) on either side

Size: max. 1250 x 2500 mm

Weight: 4.0 mm: 5.5 kg/m<sup>2</sup>

## Micro chipboard



### Application

This inexpensive panelling is inserted directly into the 8 mm slot on extrusions. The panels are lined with a white film on either side. They are highly fire-retardant and are used most commonly in the construction of exhibition stands and shop fittings.

### Specification

Plastic-coated pressboard.

Highly fire-retardant according to DIN 4102

Thickness: 6 mm

Size: max. 2100 x 2800 mm

Colour: white

Other colours and dimensions are available on request.

Weight: 5.2 kg/m<sup>2</sup>

Order data	Order number
DIBOND 2 mm	A51-12 A x B
DIBOND 3 mm, state colour	A51-13 A x B

Order data	Order number
ALUCOBOND 4 mm anodised	A51-22 A x B
ALUCOBOND 4 mm rolled matt	A51-24 A x B

Order data	Order number
Micro dense fibreboard	A50-57 A x B

## Full-plastic panels



### Application

For enclosures subject to heavy loads. Suitable for metal machining and hot or cold forming. Plastic panels are inserted directly into the extrusion channels or fitted by means of A/B30-... fixing brackets or A64-... quick-release fasteners.

### Specification

Rigid plastic foam,  
scratch-proof and impact-resistant,  
oil-resistant  
highly fire-retardant according to DIN  
4102 (self-extinguishing)  
Thicknesses: 3, 4, 6, 8 mm  
Size: max. 1220 x 2440 mm  
Weight: 3 mm: 2.1 kg/m<sup>2</sup>  
4 mm: 2.8 kg/m<sup>2</sup>  
6 mm: 4.2 kg/m<sup>2</sup>  
8 mm: 5.6 kg/m<sup>2</sup>  
Colour: white

Other colours may be supplied on request.

## Acrylic glass



### Application

For machine safety enclosures, room partitions and display cases. Suitable for metal machining and hot forming.

### Specification for acrylic glass

Colours: transparent, blue, smoked  
effect or tinted brown  
Thicknesses: 3, 4, 5, 6, 8 mm  
Size: max. 2000 x 3000 mm  
Weight: 3 mm: 3.55 kg/m<sup>2</sup>  
4 mm: 4.70 kg/m<sup>2</sup>  
5 mm: 5.90 kg/m<sup>2</sup>  
6 mm: 7.10 kg/m<sup>2</sup>  
8 mm: 9.45 kg/m<sup>2</sup>

## Polycarbonate



### Specification for polycarbonate

Colours: transparent, tinted brown  
Thicknesses: 3, 4, 5, 6, 8 mm  
Size: max. 2000 x 3000 mm  
Weight: 3 mm: 3.60 kg/m<sup>2</sup>  
4 mm: 4.80 kg/m<sup>2</sup>  
5 mm: 6.00 kg/m<sup>2</sup>  
6 mm: 7.20 kg/m<sup>2</sup>  
8 mm: 9.60 kg/m<sup>2</sup>

Order data	Order number
3 mm all-plastic panel	A50-63 A x B
4 mm all-plastic panel	A50-64 A x B
6 mm all-plastic panel	A50-66 A x B
8 mm all-plastic panel	A50-68 A x B

Order data	Order number
3 mm acrylic glass, state colour	A50-13 A x B
4 mm acrylic glass, state colour	A50-14 A x B
5 mm acrylic glass, state colour	A50-15 A x B
6 mm acrylic glass, state colour	A50-16 A x B
8 mm acrylic glass, state colour	A50-18 A x B

Order data	Order number
3 mm polycarbonate, state colour	A50-33 A x B
4 mm polycarbonate, state colour	A50-34 A x B
5 mm polycarbonate, state colour	A50-35 A x B
6 mm polycarbonate, state colour	A50-36 A x B
8 mm polycarbonate, state colour	A50-38 A x B

## Steel wire mesh



### Application

For safety guards, store partitions. Can be inserted directly into the 8 mm slot on the extrusion together with the B19-6 U-clamping extrusion.

### Specification

Zinc-coated steel

Mesh width: 40 mm

Wire thickness: 4 mm

Size: max. 1000 x 2000 mm

Weight: 4.5 kg/m<sup>2</sup>

Aluminium woven wire mesh available on request.

### Application

For an easy suspension of elements. Extrusion frames with panel-elements can be placed between two extrusions. The vertical and the horizontal suspend position hold the panels in the defined position. The nuts are placed in the slot and with screws it can be fixed from both sides.



## Suspended guard fittings

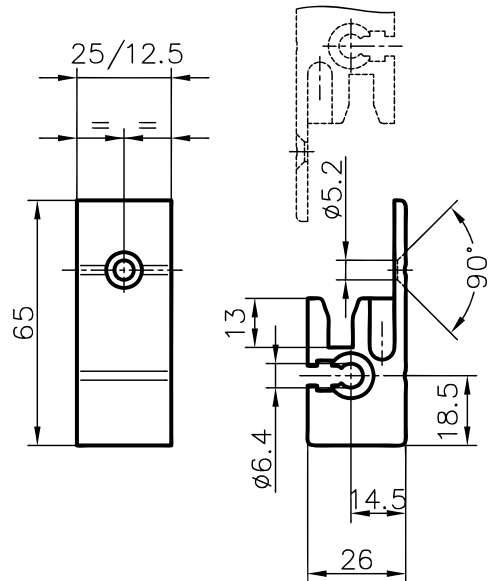

### Parts supplied

2 Suspensions + 2 Screws with Screw-nuts

### Specification

Al, anodised in natural colours

Order data	Order number
Steel wire mesh	A50-44 AxB

Order data	Order number
Suspension small	B=12.5 mm B62-20
Suspension large	B=25.0 mm B62-25

### Plastic hinges fix

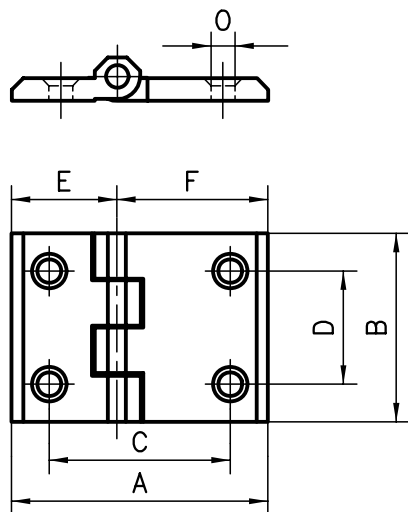

#### Application

That the optimal pivoting characteristics is given for doors, windows ect, the designer needs a selection of hinges, which are fitting exactly.



#### Specification

PA-GF black  
Pin: steel zinc coated

Order data	Order number						
Base	A	B	C	D	E	F	O
50	76	50	56	30	38	38	6.3
50/30	63	50	43	30	25	38	6.3
30	50	50	30	30	25	25	6.3

\*Fixing kit: add- to the order number

### Plastic hinges lift-off type

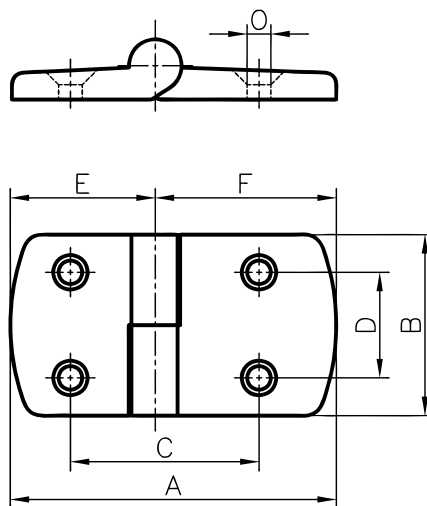

Whether cost efficient plastic, attractive diecasting, or high-strength Aluminium hinges, the assortment gives you the possibility to do the right choice.



Image: right fixed type

#### Specification

PA-GF black  
Pin: steel zinc coated

Order data	Order number						
Base	A	B	C	D	E	F	O
50	96	48	55	28	48	48	6.5
50/40	86	48	50	28	48	38	6.5
50/30	77	48	45	28	48	29	6.5
40	76	48	45	28	38	38	6.5
40/30	67	48	40	28	38	29	6.5
30	58	48	35	28	29	29	6.5

#### Aluminium hinges

Order data	Order number						
Base	A	B	C	D	E	F	O
50	92	50	54	30	46	46	6.5
50/40	82	50	49	30	46	36	6.5
40	72	50	44	30	36	36	6.5

\* Fixing kit: add- to the order number

### Aluminium hinges lift-off type

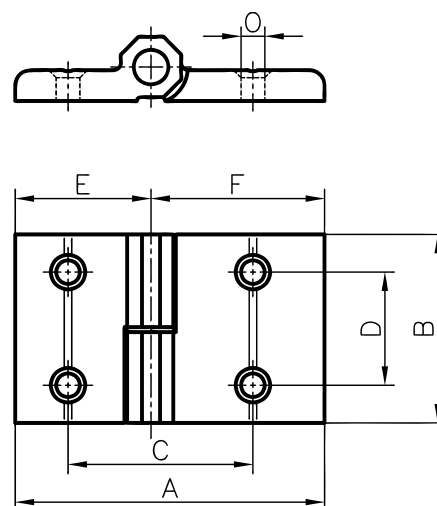

Whether cost efficient plastic, attractive diecasting, or high-strength Aluminium hinges, the assortment gives you the possibility to do the right choice.



Image: left fixed type

#### Specification

Al anodised natural colours  
Pin: steel zinc coated

Order data	Order number						
Base	A	B	C	D	E	F	O
50	96	48	55	28	48	48	6.5
50/40	86	48	50	28	48	38	6.5
50/30	77	48	45	28	48	29	6.5
40	76	48	45	28	38	38	6.5
40/30	67	48	40	28	38	29	6.5
30	58	48	35	28	29	29	6.5

#### Aluminium hinges

Order data	Order number						
Base	A	B	C	D	E	F	O
50	92	50	54	30	46	46	6.5
50/40	82	50	49	30	46	36	6.5
40	72	50	44	30	36	36	6.5

\* Fixing kit: add- to the order number

### Zn-diecasting hinges fixed type

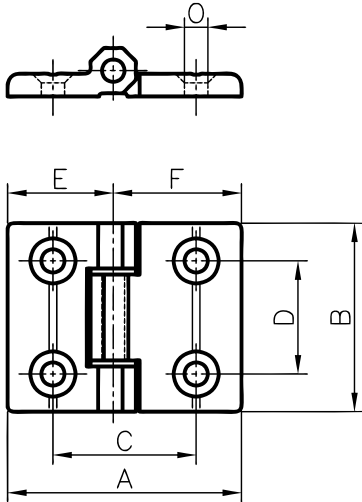

#### Specification

GD-Zn, black powder coated  
Pin: steel zinc coated  
washer: PA-6, white

### Al-heavy duty hinges fixed type

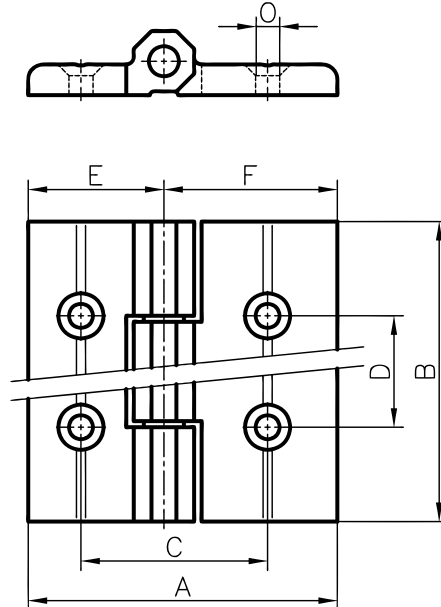

#### Specification

Al, anodised natural colours  
Pin: steel zinc coated  
bush bearing: iglidur G, grey

### Special hinges lift-off type

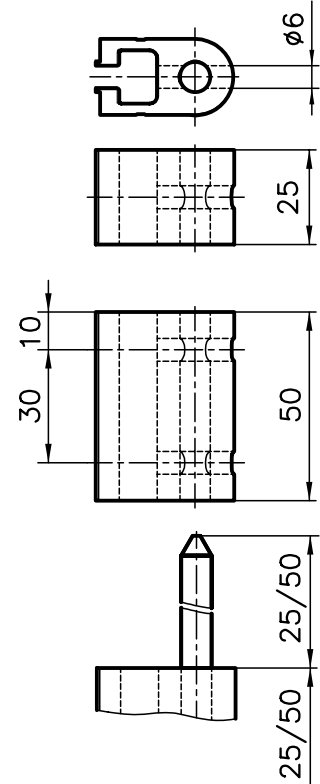

#### Specification

Al anodised natural colours  
Pin: steel zinc coated

#### Order data

#### Order number

##### Zn-diecasting hinges

Base	A	B	C	D	E	F	O
50	78	50	54	30	39	39	6.3
50/40	73	50	49	30	34	39	6.3
50/30	67	50	43	30	28	39	6.3
40	68	50	44	30	34	34	6.3
40/30	62	50	38	30	28	34	6.3
30	56	50	32	30	28	28	6.3
20	40	40	25	25	20	20	5.3

A60-20 (-S)*
AC6-20 (-S)*
AB6-20 (-S)*
C60-20 (-S)*
CB6-20 (-S)*
B60-20 (-S)*
D60-00 (-S)*

##### Al-heavy duty hinges

Base	A	B	C	D	E	F	O
50	92	100	54	75	46	46	6.3
50/40	82	100	49	75	36	46	6.3
40	72	100	44	75	36	36	6.3

A60-30 (-S)*
AC6-30 (-S)*
C60-30 (-S)*

\*Fixing kit: add -S to the order number

#### Order data

#### Order number

	L = 25	L = 50
Hinge component , no pin	A60-50	A60-55
Hinge component, with a pin	A60-51	A60-56

## Joint

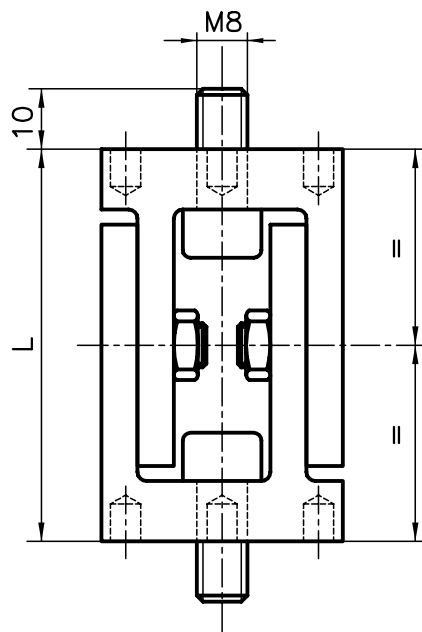
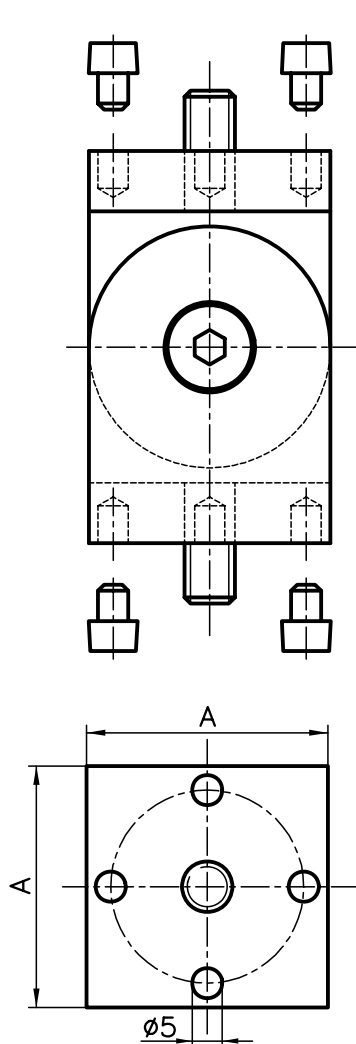

## Joins with clamp lever

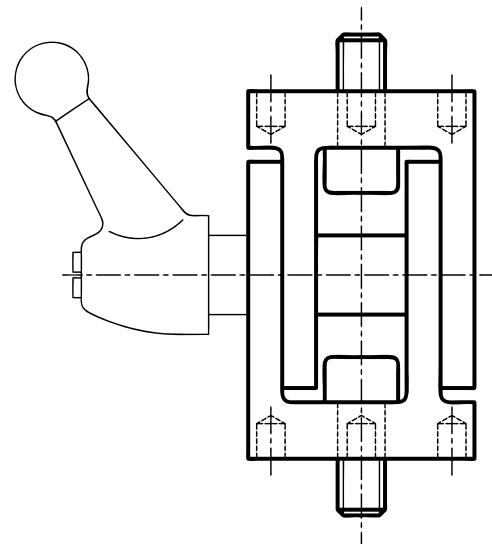

### Application

Mainly used to strengthen structures with diagonal braces. It is also suitable to be used as a hinge for swivelling equipment stands, doors, etc. The (5 mm holes are designed to take dowels (which are included). Insert the dowels to give greatest stability.

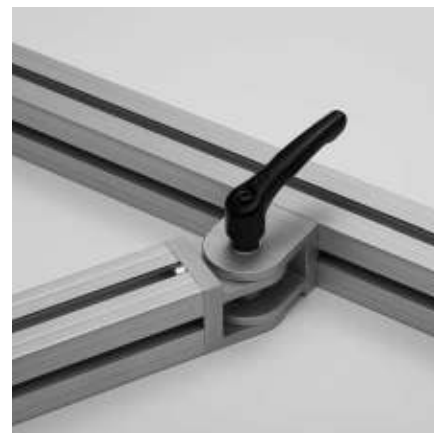

### Specification

Aluminium, matt, anodised in natural colours

Screws and flats: zinc-coated steel

### Parts supplied

- 2 assembled joint halves
- 2 M8 fixing screws
- 2 threaded plates
- 4 flats



### Specification

Aluminium, matt, anodised in natural colours

Screws and flats: steel zinc coated

### Parts supplied

- 2 assembled joint halves
- 2 M8 fixing screws
- 1 clamp lever with the distance bush
- 2 threaded plates
- 4 flats

Order data	Order number		
Joint	A	L	
Base 50	50	85	A61-00
Base 40	40	65	C61-00

Order data	Order number		
Joint with clamping lever	A	L	
Base 50	50	85	A61-01
Base 40	40	65	C61-01

## Corner pieces



### Application

Gives an attractive finish to the corners of display cases, work benches, office furniture, cabinets and other well designed structures. Available rounded or diagonally cut.

### Fixing kit\*

3 PVS connectors with thread

### Specification

Aluminium, anodised in natural colours  
Attached by a PVS threaded connector



Order data	Order number	
	round	flat
Corner piece		
Base 50 extrusion corner piece	A70-00(-S)*	A71-00(-S)*
A02-8 extrusion corner piece		A71-08(-S)*
Base 40 extrusion corner piece	C70-00(-S)*	C71-00(-S)*
C02-8 extrusion corner piece		C71-08(-S)*
Base 30 extrusion corner piece	B70-00(-S)*	B71-00(-S)*
Base 20 extrusion corner piece	D70-00(-S)*	D71-00(-S)*

\*Fixing kit: add -S to the order number

# Handles

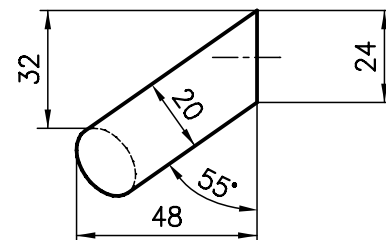
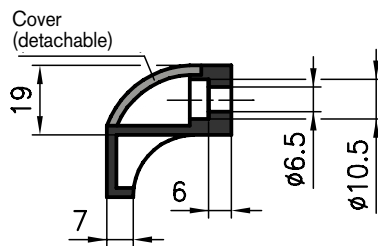
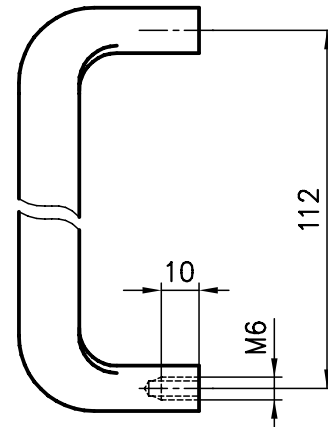
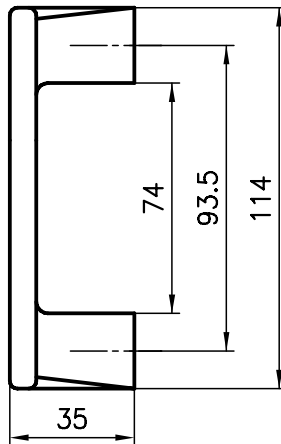
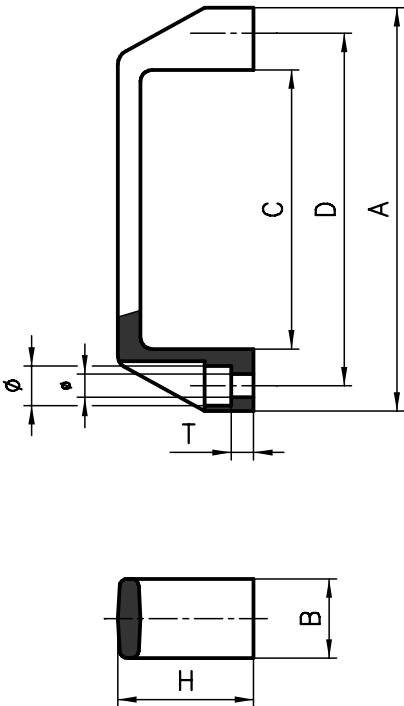

**Application**

Highly versatile. Two sizes are available from standard stock. Fixed in place from the inside or outside using M5/8 screws.

**Specification**

PA-GF, black

**Measurement data**

Handle	A	B	C	D	H	T	Ø	ø
small	17	21	74	93.5	36	6	10.5	6.5
medium	122	19	82	100	33	13	8.5	5.5
large	134	26	95	117	41	6.5	13.5	8.5

**Application**

A modern looking, ergonomic handle (mainly used on 20 and 30 base extrusions).

**Specification**

PA-GF, black

**Colours of covers:**

dark grey, grey, yellow, orange, blue, red

**Application**

For inset, sliding doors etc. This offset handle ensures no trapped fingers.

**Specification**

Black aluminium RAL 9005 (plastic coated)  
Natural anodised aluminium



**Order data      Order number**

Small handle      B65-00  
Medium handle    B65-01  
Large handle      A65-01

**Order data      Order number**

Ergo handle      D65-01 + colour  
of cover

**Order data      Order number**

handle            black    anodised  
A65-05    A65-06

### Tube handle offset

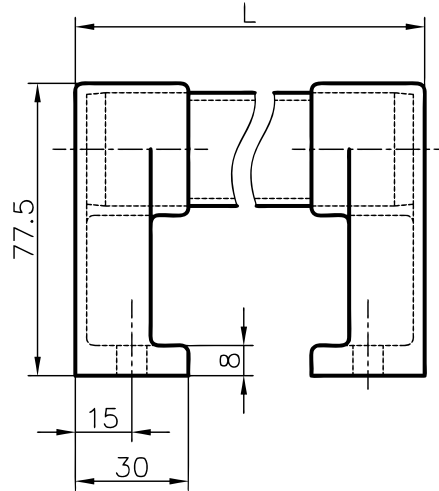
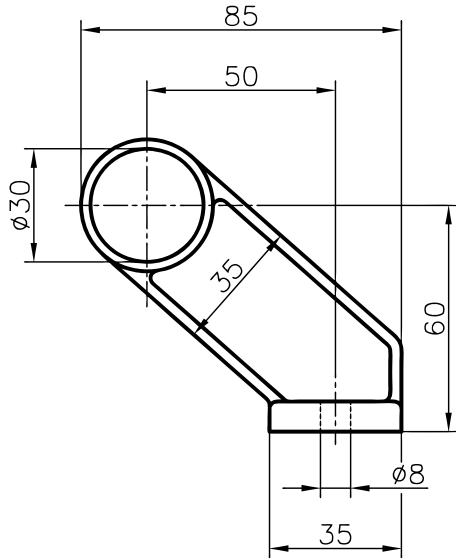

### Tube handle straight

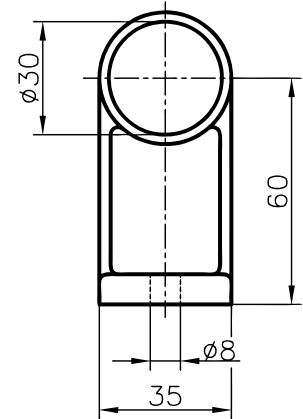

#### Application

These strong tubing grasps are suitable for heavy sliding doors, large windows or also as impact handles for trolleys.

With double sliding doors and critical space conditions, anywhere that risk of trapping hands exists, the offset tubing grasp is highly recommended.



#### Specification

Support: PA-GF, black  
Tube: Al, anodised

Order data	Order number
	L
tube handle offset	250mm A65-22
tube handle offset	300mm A65-23
tube handle offset	400mm A65-24
tube handle offset	500mm A65-25
Other length on customers requirement available	



#### Specification

Support: PA-GF, black  
Tube: Al, anodised

Order data	Order number
	L
Tube handle straight	250mm A65-12
Tube handle straight	300mm A65-13
Tube handle straight	400mm A65-14
Tube handle straight	500mm A65-15
Other length on customers requirement available	

### Ball catches

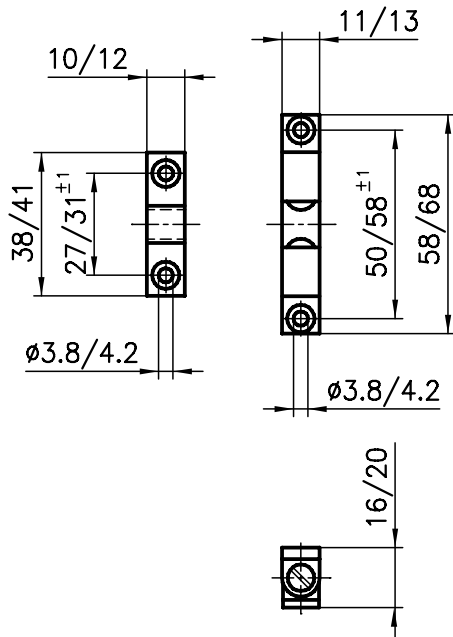

#### Application

The ball catches are used as an adjustment of sliding and swing doors and are ideal for mounting of movable components. For the ball catch A67-20 are spacers of 4 mm thickness available.

#### Specification

Brass (chromium-plate steel balls)



Order data	Order number
Small ball catch	A66-00
Large ball catch	A66-10

### Ball catches

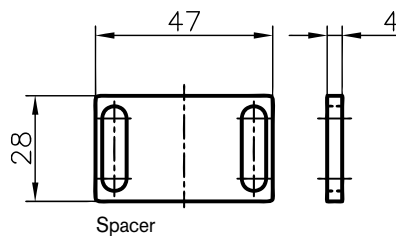
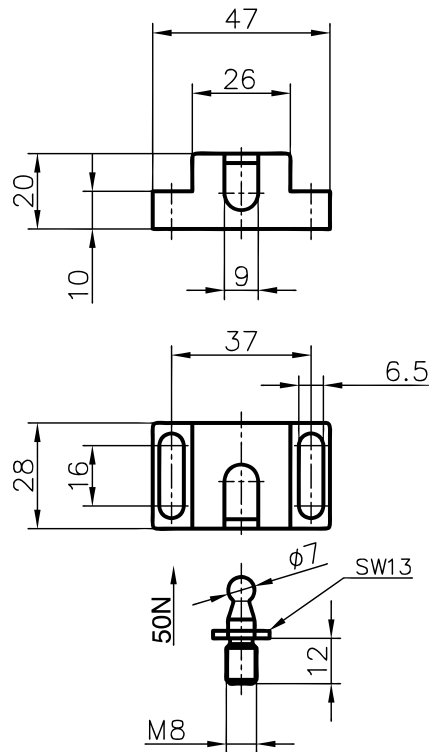

#### Specification

PA-GF, black  
fixing screw: steel zinc coated



Order data	Order number
Ball catch	A66-50
Spacer	A66-54

### Magnetic fasteners

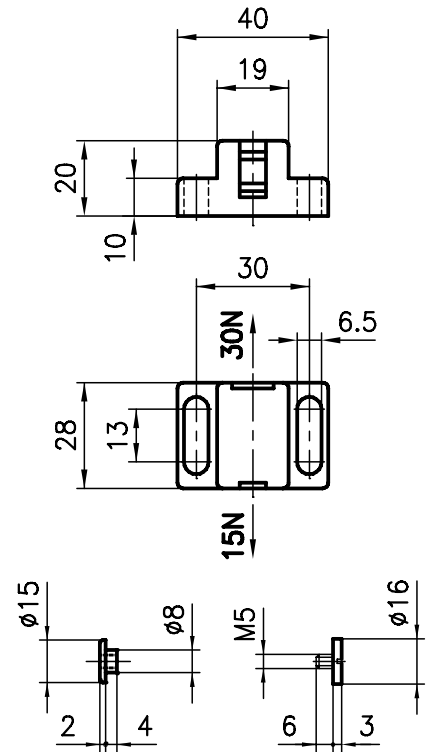

#### Application

This magnetic catch is highly adaptable. You can choose between two retention forces, depending on your requirements. The elongated holes also permit a large adjustment range.

#### Specification

Black plastic with a permanent magnet / pan-head screw with nut.



Order data	Order number
Duo magnetic catch	A67-20

## Handle strip

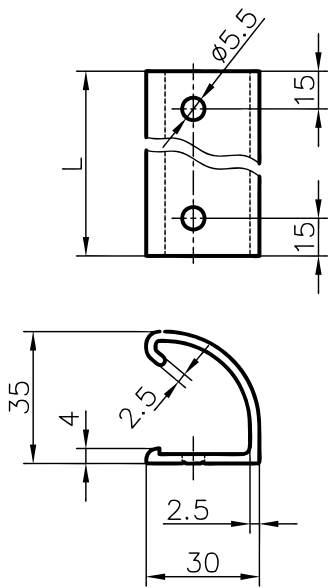

### Application

The handle strip is used as drawer handle. It's also possible to use it for doors and windows



### Specification

Al, anodised in natural colour

Order data	Order number
Handle strip 200 mm	B65-52
Handle strip 300 mm	B65-53
Handle strip 400 mm	B65-54

Other length on customer requirement available

## Arrester plate

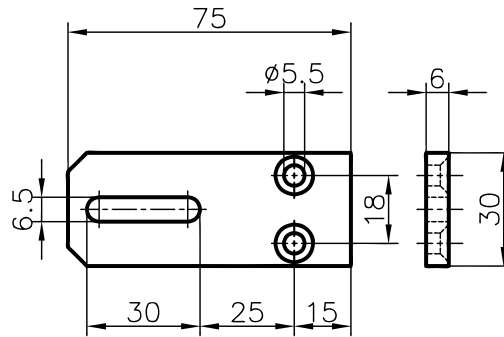

### Application

As door- or window arresters with fixing possibility. It is possible to screw the arrester plate through the slot and make it secure. It's also qualified as a simple connecting element.



### Specification

Al, anodised in natural colour

### Fixing kit\*

Screws + double threaded plate

Order data	Order number
Arrester plate	C62-10 (-S)*

\*Fixing kit: add -S to the order number

## Quick-release fasteners

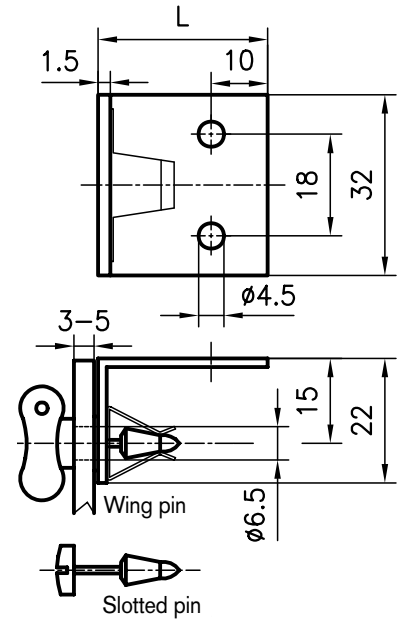

### Application

For the quick fitting and removal of paneling. Simply press the wing or slotted pin in with your thumb; a quarter turn releases it.



### Specification

Brackets and bolts: stainless steel  
Spacer ring: rubber

### Fixing kit\*

Screws and threaded plates

Order data	Order number
Quick-release fastener with a wing pin	L = 18      L = 30 A64-10(-S)*    A64-11(-S)*
Quick-release fastener with a slotted pin	A64-20(-S)*    A64-21(-S)*

\* Fixing kit: add -S to the order number

## Rod locks

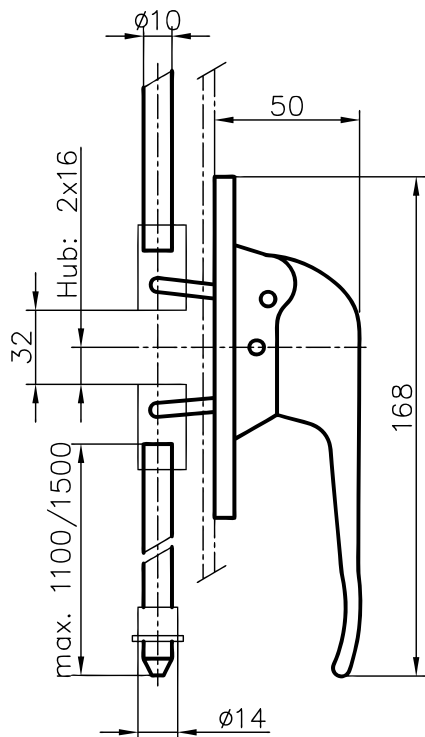

### Application

The rod bolt is installed inside 50,40 and 30 mm base extrusions. The extrusions have to be milled in the area of the handle. It can have a single or double rod locking mechanism. The rod is cut to the appropriate installation length.

### Specification

Handle: Al, anodised in natural colours  
 Rod: zinc-coated steel  
 max. length per rod: base 50/40 max. 1500mm  
 base 30 max. 1100mm

### Fixing kit\*

Screws and threaded plates, guide bushes

	Order data		Order number
<b>Rod lock Al lockable, 2 keys</b>			
Base	50	40	30
1 rod	A68-14 (-S)*	C68-14 (-S)*	B68-14 (-S)*
2 rods	A68-15 (-S)*	C68-15 (-S)*	B68-15 (-S)*
<b>Rod lock Al unlockable</b>			
1 rod	A68-04 (-S)*	C68-04 (-S)*	B68-04 (-S)*
2 rods	A68-05 (-S)*	C68-05 (-S)*	B68-05 (-S)*

\*Fixing kit: add -S to the order number

## Inset lock

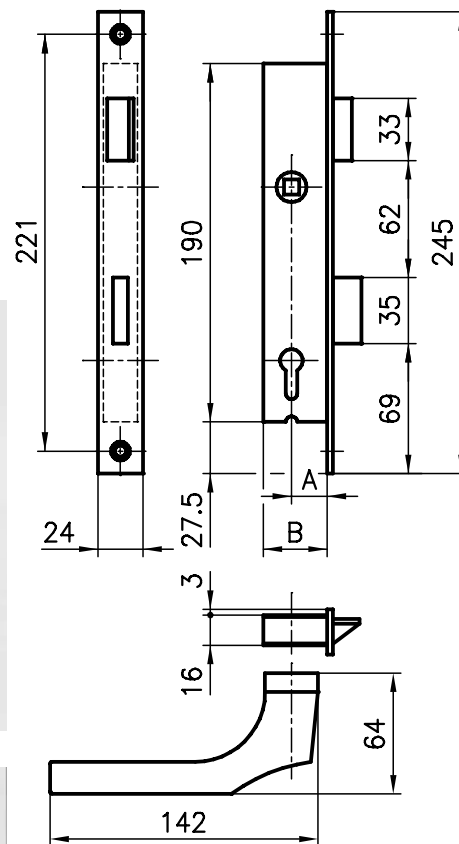

### Application

Lockable and built into the extrusions Base 50, 40 and 30. The extrusion must be milled.

### Specification and parts supplied

Lock: zinc-coated steel  
 Cylinder: Nickel plated brass  
 Key: Nickel plated steel (3supplied)  
 Handle and escutcheon: Al anodised

### Fixing kit\*

Screws and threaded plates

	Order data		Order number
<b>Inset lock</b>			
	A	B	
Base 50	27	42	A68-00(-)S*
Base 40	19	34	C68-00(-)S*
Base 30	15	30	B68-00(-)S*

\* Fixing kit: add -S to the order number

### Snap-lock

### Safety switch

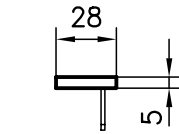
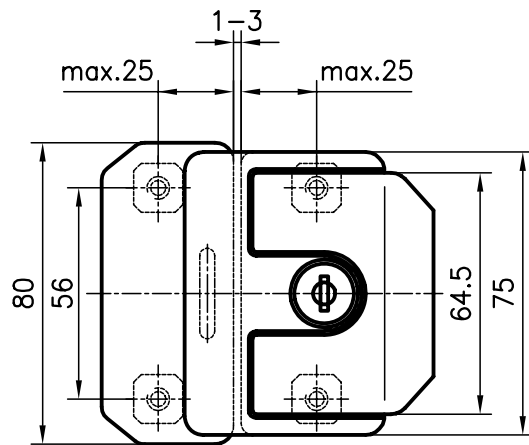
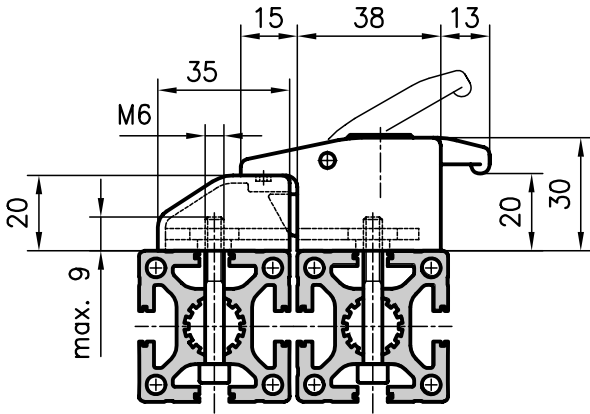

Magnet or ball catch

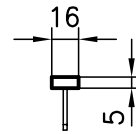

Standard

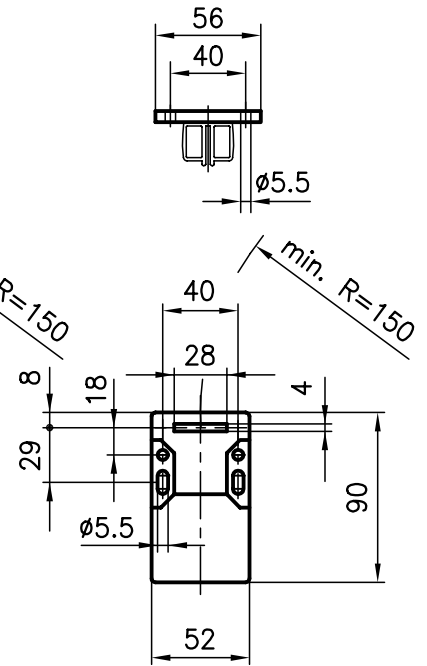
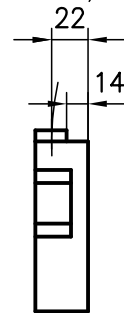
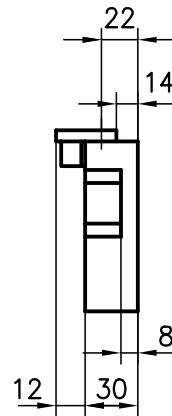

#### Application

The snap-lock comprises a door housing with a latch as well as a framework housing. Its versatile design allows the lock to be used for different widths of extrusion. Another advantage is that it is very easy to open and close.

#### Specification

GD-Zn, black  
instant locking, 2 keys  
Four M6 square nuts

Order data	Order number
Snap-lock	A68-50



#### Application

Used as a closing or opening contact on safety doors, etc. Used to enable and disable automatic processes.

#### Specification

- standard
- with a magnet (retention force 30 N)
- with a ball catch (retention force of up to 100 N)

Order data	Order number
Safety switches (1 break contact, 1 make contact)	
standard	C63-00
magnet	C63-01
ball catch	C63-02

Other switches and hinge switches available on request.

## Sealing plates

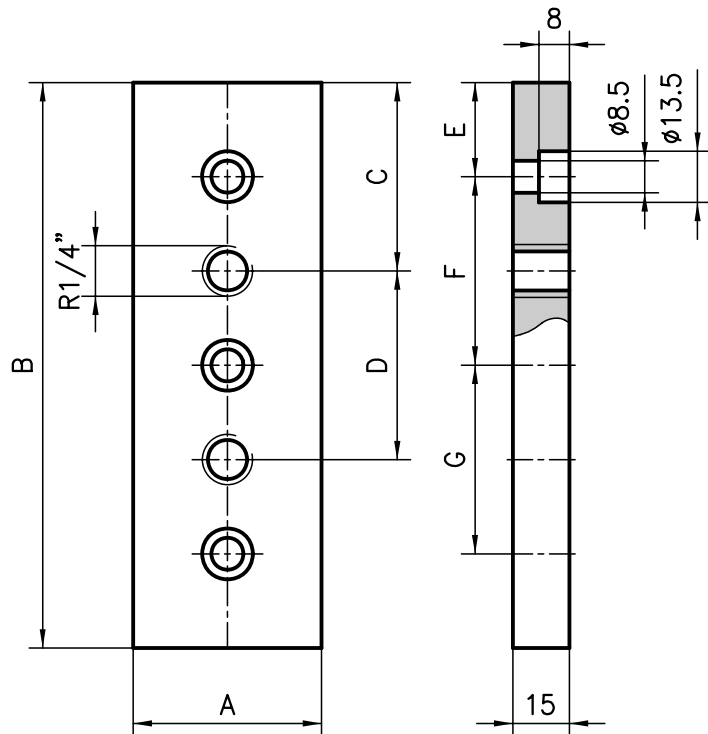

## Flat sealing element

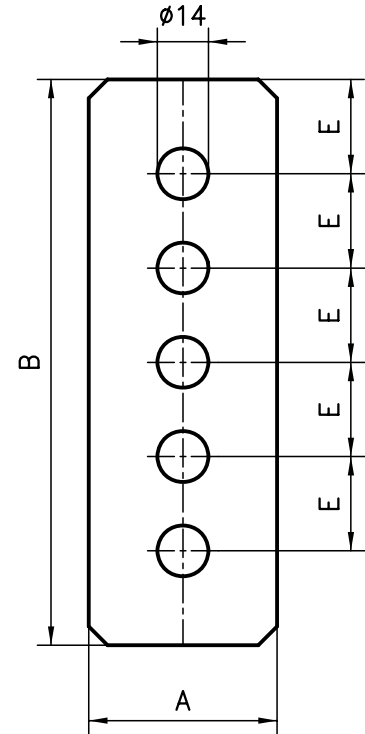

### Application

To seal the cut ends of manifold extrusions. Air, water, oil or other media can be supplied or drained off with the appropriate gas fittings.



### Fixing kit\*

Screws + threaded inserts

### Specification

Al, anodised in natural colours  
1/4" gas connection

Order data	Order number							
Sealing plate	A	B	C	D	E	F	G	
40x80 extrusion	40	80	40	-	20	40	-	C80-30(-S)*
50x100 extrusion	50	100	50	-	25	50	-	A80-10(-S)*
50x150 extrusion	50	150	50	50	25	50	50	A80-30(-S)*

Order data	Order number
<b>Flat sealing element for the sealing plate</b>	
40x80 extrusion	C80-31
50x100 extrusion	A80-11
50x150 extrusion	A80-31

\* Fixing kit: add -S to the order number

## Sealing washer

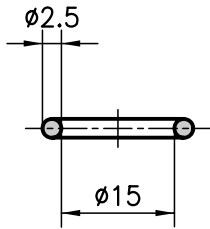

### Application

The flat seal between the sealing plate and the extrusion end or a sealing washer between the junction plates and the side of the extrusion guarantees a seal up to 6 bar.

### Specification

Black nitrile rubber  
70 shore A

## Junction plates

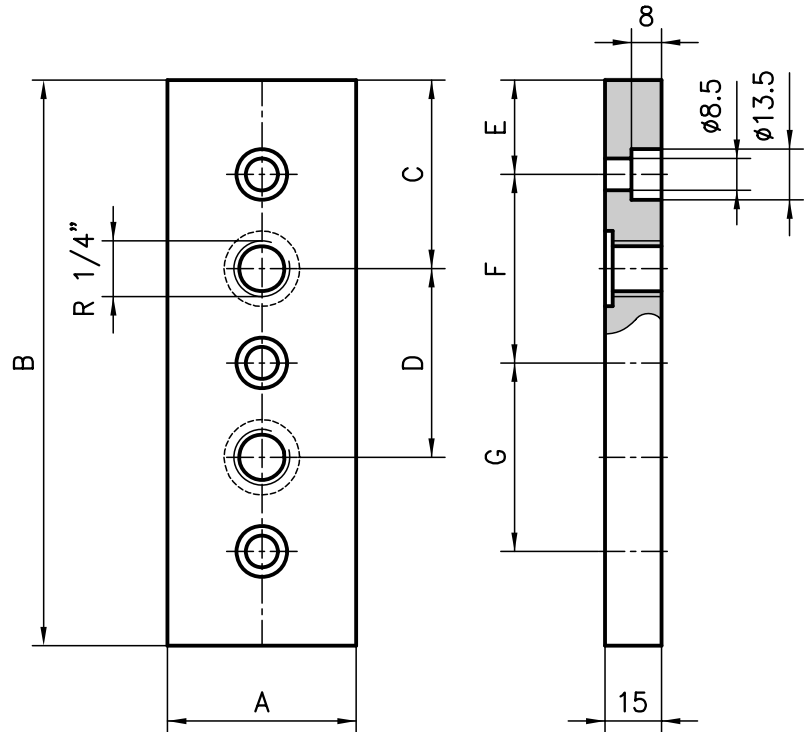

### Application

High pressure junction plate for side connections (> 6 bar). The thread for the junction is normally tapped directly into the side of the extrusion. No junction plates are required for side connections to the 40x80 extrusion.

### Fixing kit\*

Screws + threaded plates

### Specification

Al, anodised in natural colours  
1/4" gas connection



Order data	Order number
Junction plate sealing washer	
50x100	A80-41
50x150 (2 x)	A80-42

Order data								Order number
Junction plate	A	B	C	D	E	F	G	
50x100 extrusion	50	100	50	-	25	50	-	A80-40(-S)*
50x150 extrusion	50	150	50	50	25	50	50	A80-50(-S)*

\* Fixing kit: add -S to the order number

## Shaft clamping block

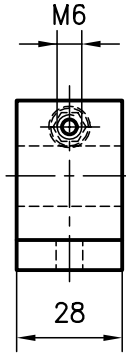
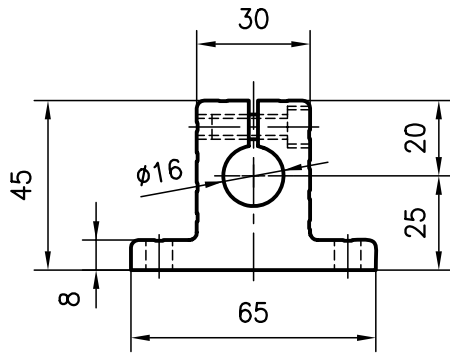

Shaft clamping block – straight

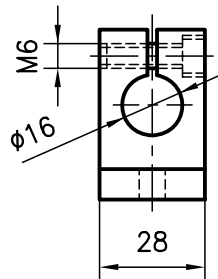
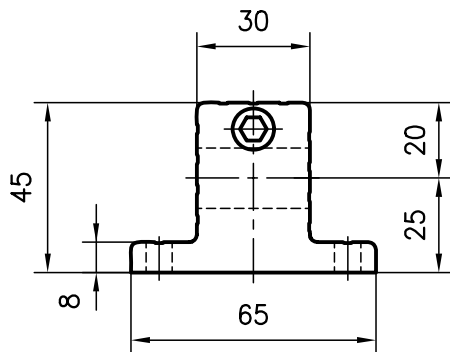
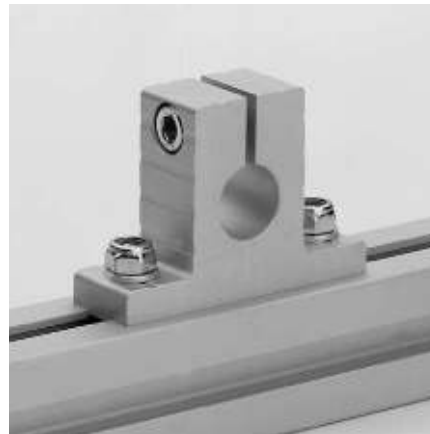
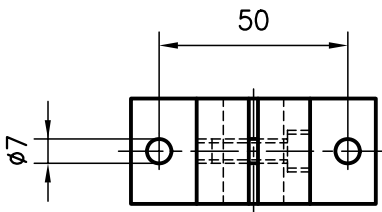

Shaft clamping block – 90°

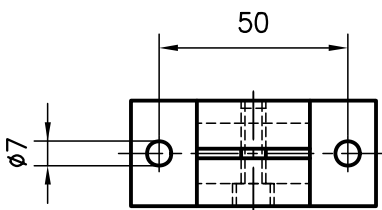

### Application

A high-precision linear bearing system can be created very easily with the components, i.e. the shaft clamping block, the linear bearing block and the steel shaft. As there are two different shaft clamping blocks, the system can be assembled flexibly. The fixing centres combine well with the PVS extrusions.

### Specification

Aluminium, anodised in natural colours



### Order data

### Order number

Shaft clamping block – straight L16-60  
 Shaft clamping block – 90° L16-65

## Linear sliding block

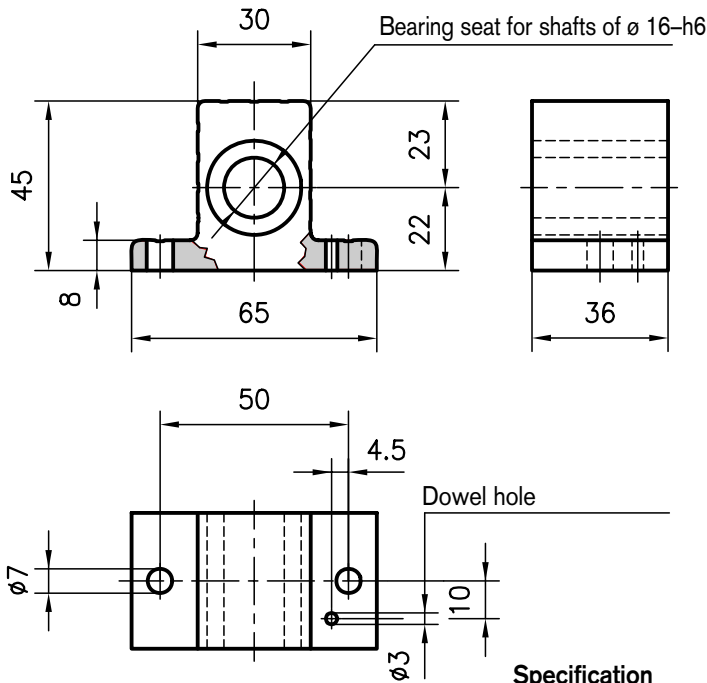

### Specification

Housing: aluminium, anodised in natural colours

Linear bearing: steel, sealed on both sides, maintenance-free

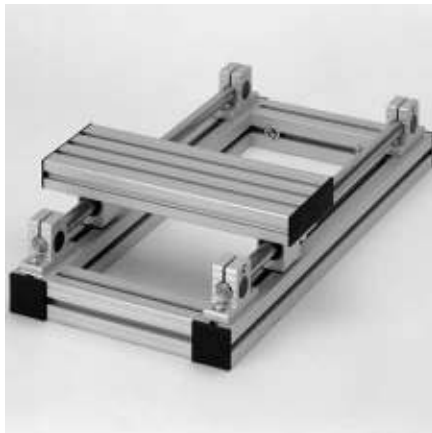

## Steel shafts

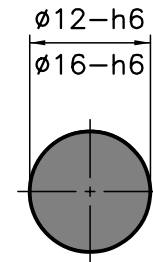

### Application

The steel shafts are used in combination with the linear sliding block and the shaft clamping blocks assembled on the appropriate extrusion framework. This serves to create high load-bearing linear guides.

### Specification

Steel, Cf 53, hardened, ground

Hardness: HRC 62 ± 2



### Load rating

dynamic	static
850 N	620 N

### Order data

Linear sliding block

### Order number

L16-68

### Order data

Steel shaft $\phi$ 12	
Standard length 6000 mm	L12-20-01/6000
Cut to length	L12-20-02-02/...

### Order data

Steel shaft $\phi$ 16	
Standard length 6000 mm	L16-20-01/6000
Cut to length	L16-20-02-02/...

## Shaft clamping extrusions

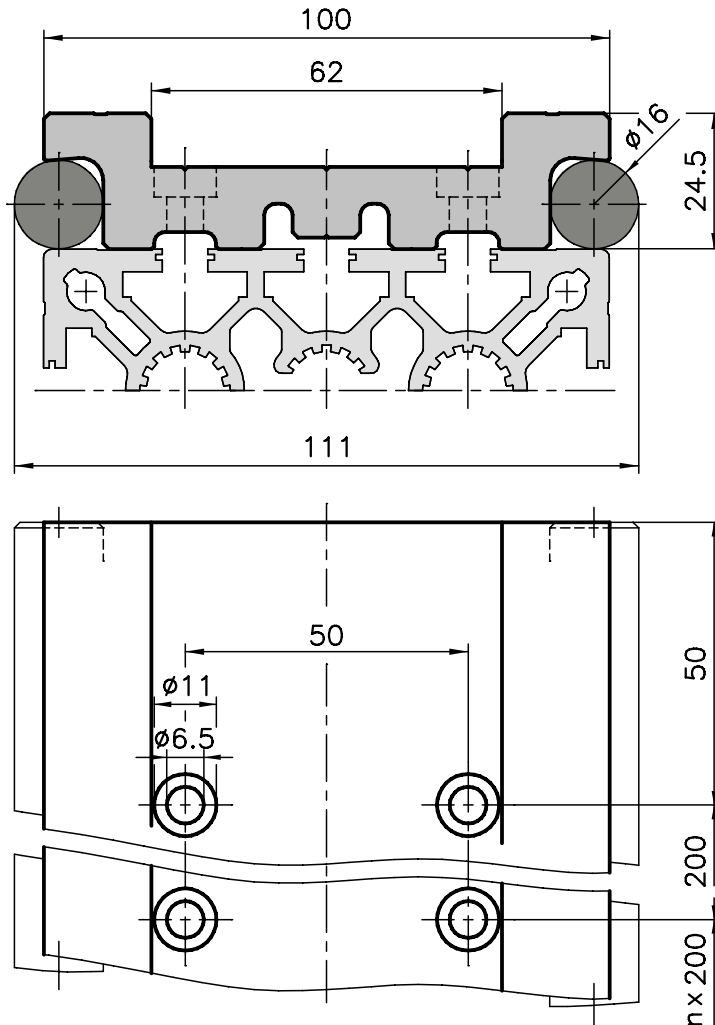
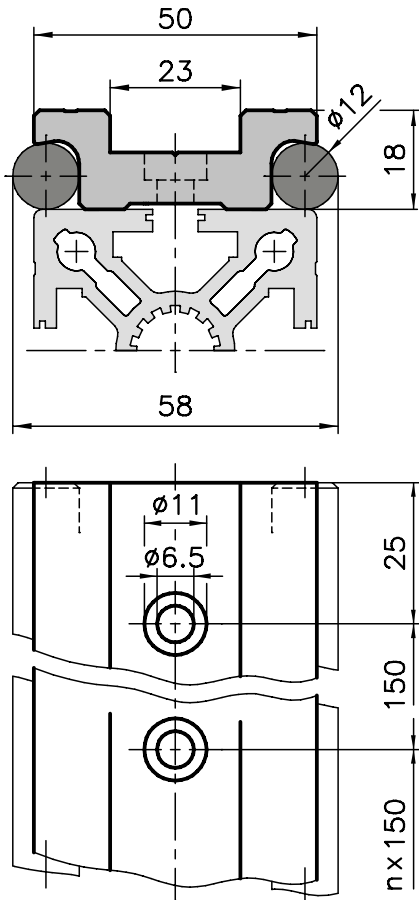

### Application

The steel shafts are fixed firmly to the Base 50/100 extrusion using the shaft clamping extrusion. They can be combined with the slide plates and rollers as a simple way to create linear slides to move very high loads.

### Specification

Aluminium, matt, anodised in natural colours

Order data	Order number
<b>Shaft clamping extrusion</b>	<b>50 mm base</b>
Standard length 6000 mm	L12-05-00/6000
Cut to length	L12-05-02-02/...
<b>Shaft clamping extrusion</b>	<b>100 mm base</b>
Standard length 6000 mm	L16-05-00/6000
Cut to length	L16-05-02-02/...

### Application

Shaft clamping extrusion complete with steel shafts Cf 53, hardened, ground and with fixing kit.

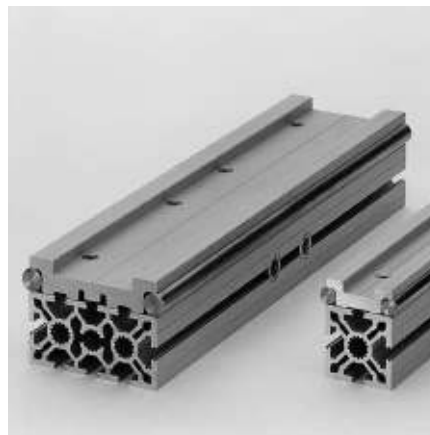

Order data	Order number
<b>Steel clamping extr., compl.</b>	<b>50 mm base</b>
Standard length 6000 mm	L12-06-00/6000
Cut to length	L12-06-02-02/...
<b>Steel clamping extr., compl.</b>	<b>100 mm base</b>
Standard length 6000 mm	L16-06-00/6000
Cut to length	L16-06-02-02/...

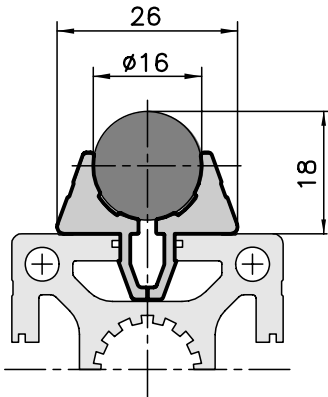

**Application**

For simpler linear slides,  $\varnothing 16$  steel shafts can be easily clipped into Base 40 or 50 extrusion using the two-part shaft clamping extrusion.

The guide extrusion 40x100 is used for high load linear slides. Centreline distance between upper and lower shafts is decided by the customer's load carrying requirement.

**Specification**

Aluminium, matt, anodised in natural colours

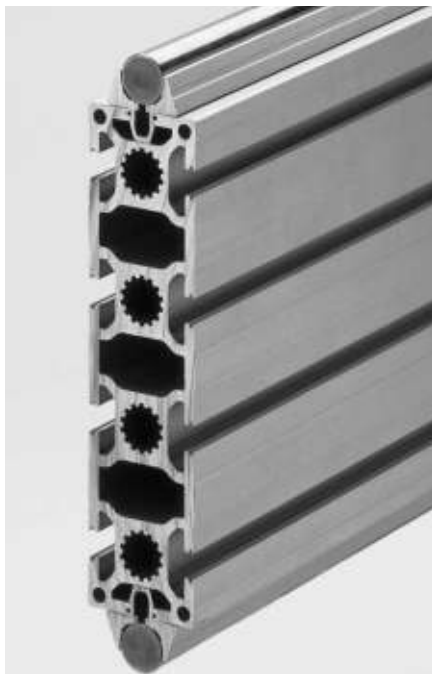

**Order data                      Order number**

Shaft clamping extrusions two-part  
 Standard length 6000 mm    L16-01-00/6000  
 Cut to length                      L16-01-02-02/...



**Shaft support extrusion type L16-10**

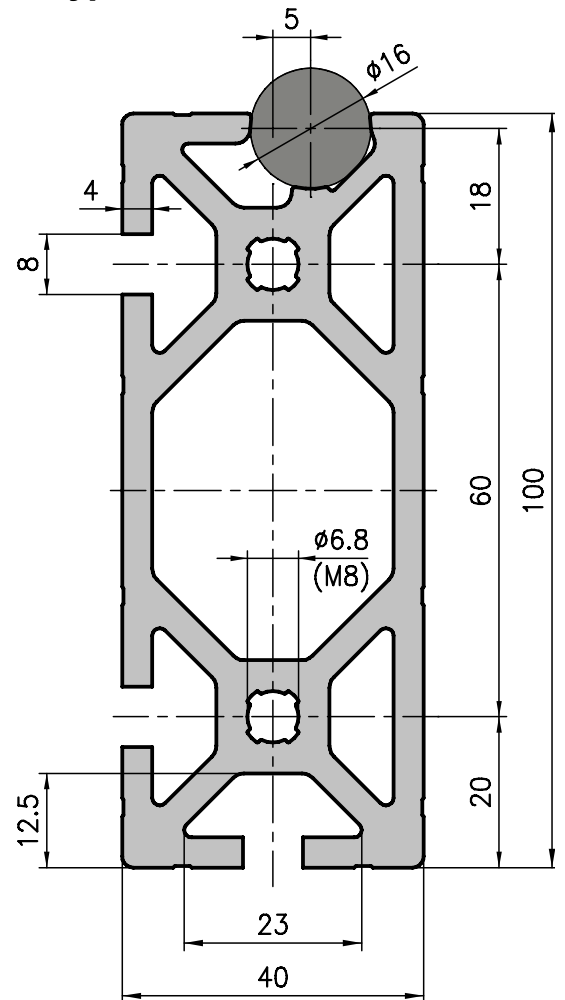

**Technical data**

$I_x$	=	172.22 cm <sup>4</sup>
$I_y$	=	31.92 cm <sup>4</sup>
$W_x$	=	33.83 cm <sup>3</sup>
$W_y$	=	15.95 cm <sup>3</sup>
Cross section area	=	16.75 cm <sup>2</sup>
Weight	=	4.5 kg/m

**Order data                      Order number**

<b>Shaft support extrusion 40x100</b>	
Standard length 6100 mm	L16-10-00/6000
<b>Shaft support extrusion 40x100</b>	
Cut to length	L16-10-02/...
Extra machining	Pages 34/35

# Slide plates

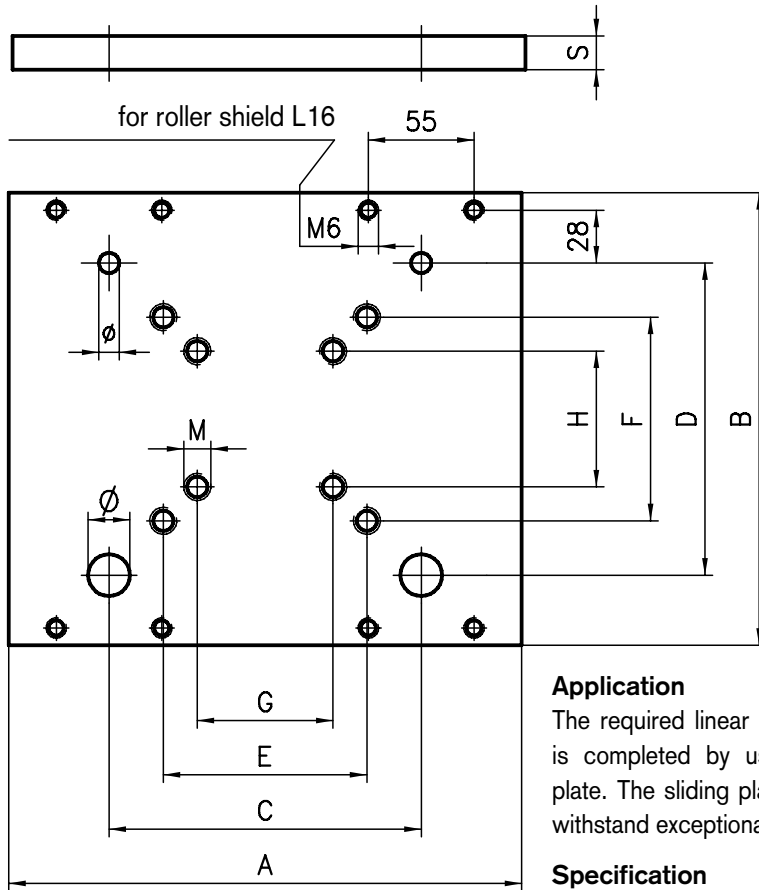

Slide plates acc. to customer drawing

### Application

The required linear slide arrangement is completed by use of the sliding plate. The sliding plate is designed to withstand exceptionally heavy loading.

### Specification

Raw aluminium

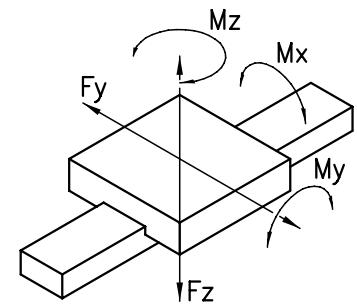

### Measurement data

#### Slide plate for use with shaft clamping extrusion

Base	A	B	C	D	E	F	G	H	M	s	Ø	ø	Weight
50	150	130	110	89	60	60	30	30	8	12	12	10	0.6 kg
100	300	240	200	158	100	100	50	50	8	15	20	17	2.9 kg

#### Slide plate for use with two part shaft clamping extrusion

Profile	A	B	C	D	E	F	G	H	M	s	Ø	ø	Weight
50x150	350	310	250	233	150	150	75	75	8	15	*20	17	4.3 kg
40x160	350	320	250	243	150	150	75	75	8	15	*20	17	4.5 kg

### Loading and moments

static [N/Nm]						dynamic [N/Nm]					
F <sub>y</sub>	F <sub>z</sub>	M <sub>x</sub>	M <sub>y</sub>	M <sub>z</sub>	Weight	F <sub>y</sub>	F <sub>z</sub>	M <sub>x</sub>	M <sub>y</sub>	M <sub>z</sub>	Weight
3000	1920	35	55	90	0.6 kg	3000	1200	22	34	90	0.6 kg
7200	3400	105	160	600	2.9 kg	7200	2100	65	100	600	2.9 kg

### Order data

### Order number

#### Slide plate for use with shaft clamping extrusion

Base 50	L12-30
Base 100	L16-31

#### Slide plate for use with two part shaft clamping extrusion

50x150 extrusion	L16-35
40x160 extrusion	L16-34

acc. to customer's drawing	L12-39
acc. to customer's drawing	L16-39

\* The Ø20 equates to the Ø of the retainer of the bolts (distance bushes)

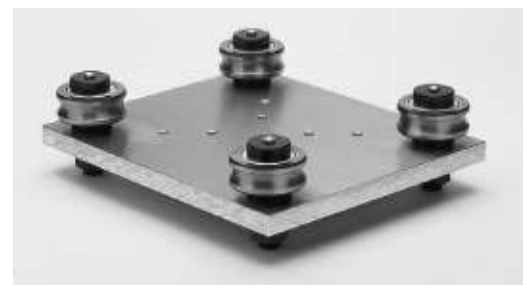

## Rollers

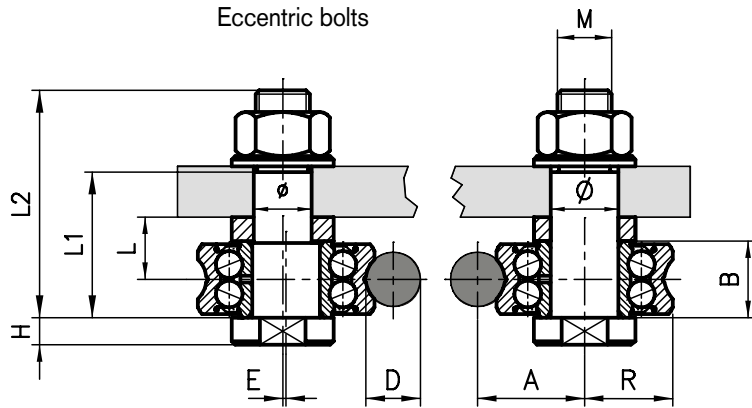

## Roller shield

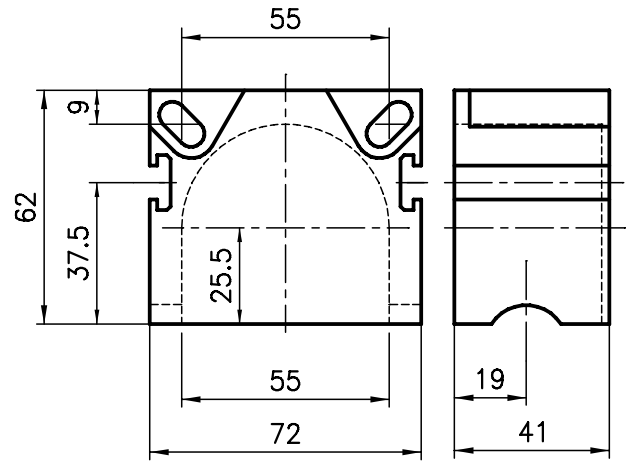

**Messure data**

											Load rating		
D	A	B	E	H	L1	L2	M	R	Ø	ø	Weight	dyn.	stat.
ø12	21.75	15.9	0.75	5	29	45	M10x1.5	17.5	12	10	0.15 kg	8400 N	5000 N
ø16	31.5	22.6	1.0	8	44	67	M16x1.5	26	20	17	0.42 kg	16800 N	9500 N

**Application**

For use with the slide plates, to do a linear guide-rail.

**Specification**

Roller: steel 100 Cr6, hardened, grinded nut and ground bolt and spacer bush: black steel

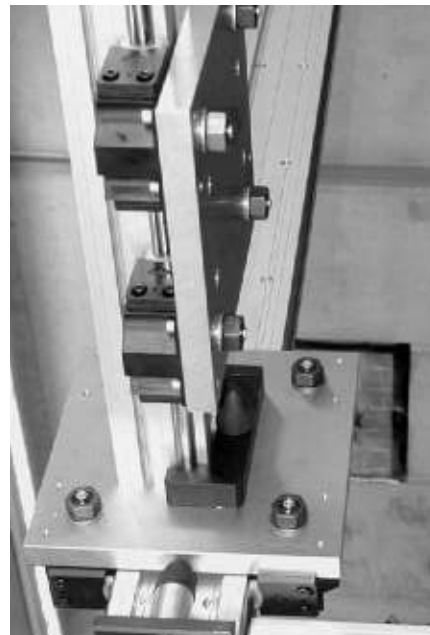

**Application**

Both to guard the roller and ect as a grease scraper

**Specification**

PA-GF, black

**Parts supplied shield complete**

- 1 roller shield
- 2 grease scrapers
- 1 set of fixing materials
- Weight: 0.15 kg

**Order data**

**Order number**

Roller for bar Ø12	centric	eccentric
L = 14	L12-25	L12-26
Roller for bar Ø16		
L = 18.5	L16-25	L16-26
L = 21.5	L16-21	L16-22
L = 26.5	L16-27	L16-28

**Order data**

**Order number**

Roller shield	L16-40
Rollershield complete	L16-45

### Spacer for the roller shield

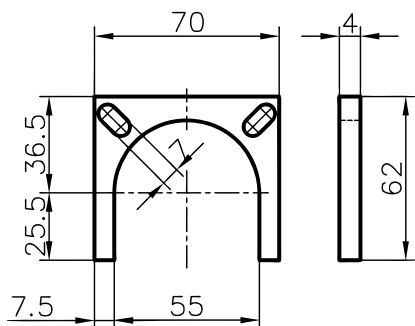

#### Application

As a spacer for the roller shield to adjust the different sizes of the rollers.

#### Specification

Aluminium, raw

Order data	Order number
Spacer	L16-40-04

### Oil scraper support

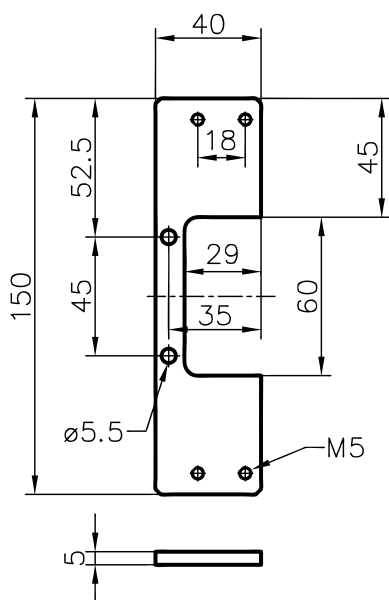

#### Application

The support fits on the slide plate base 50. Together with the oil scraper the slide for a small linear guide is complete.

#### Specification

Aluminium, anodised in natural colours

Order data	Order number
Support for oilscraper	L16-43

### Oil scraper

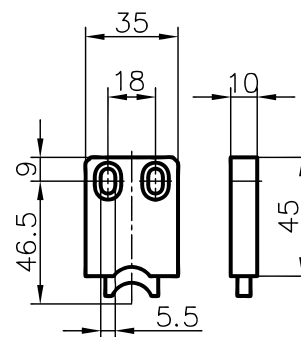

#### Application

The oil scraper is for two functions. On one hand, it cleans the steel bars and on the other it coat the steel bars with a oil film to protect it from rusting.

#### Specification

Shield: PA-GF

grease scraper: oil-impregnated felt

Order data	Order number
grease scraper	L16-46
grease scraper	L12-46

## End stop

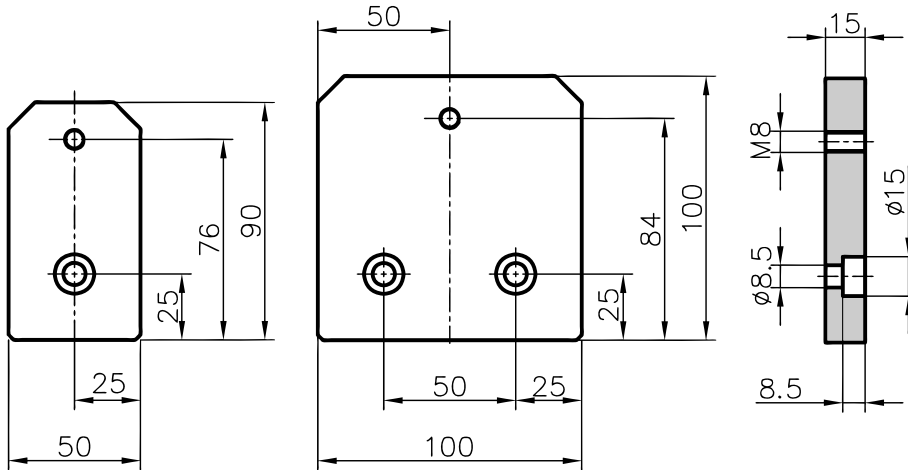

## Buffer

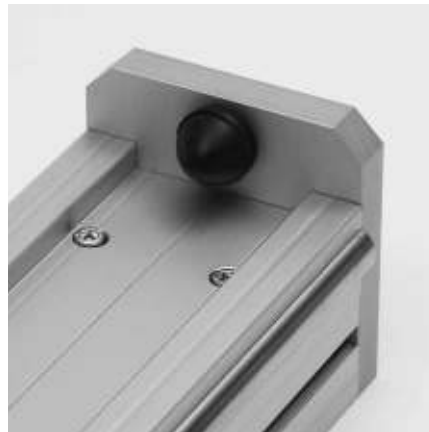
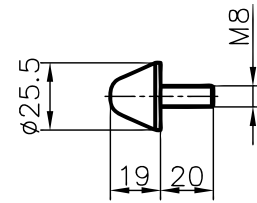

### Application

The end stopper in combination with the buffer is normally screwed on the end of the extrusions base 50, serving as a stop for the linear guides.

### Specification

Aluminium, anodised in natural colours

Order data	Order number
End stop 50	L16-55
End stop 100	L16-53



### Application

For use as an end stop for linear guides

### Specification

rubber, highly deformable

Order data	Order number
Buffer	L16-50

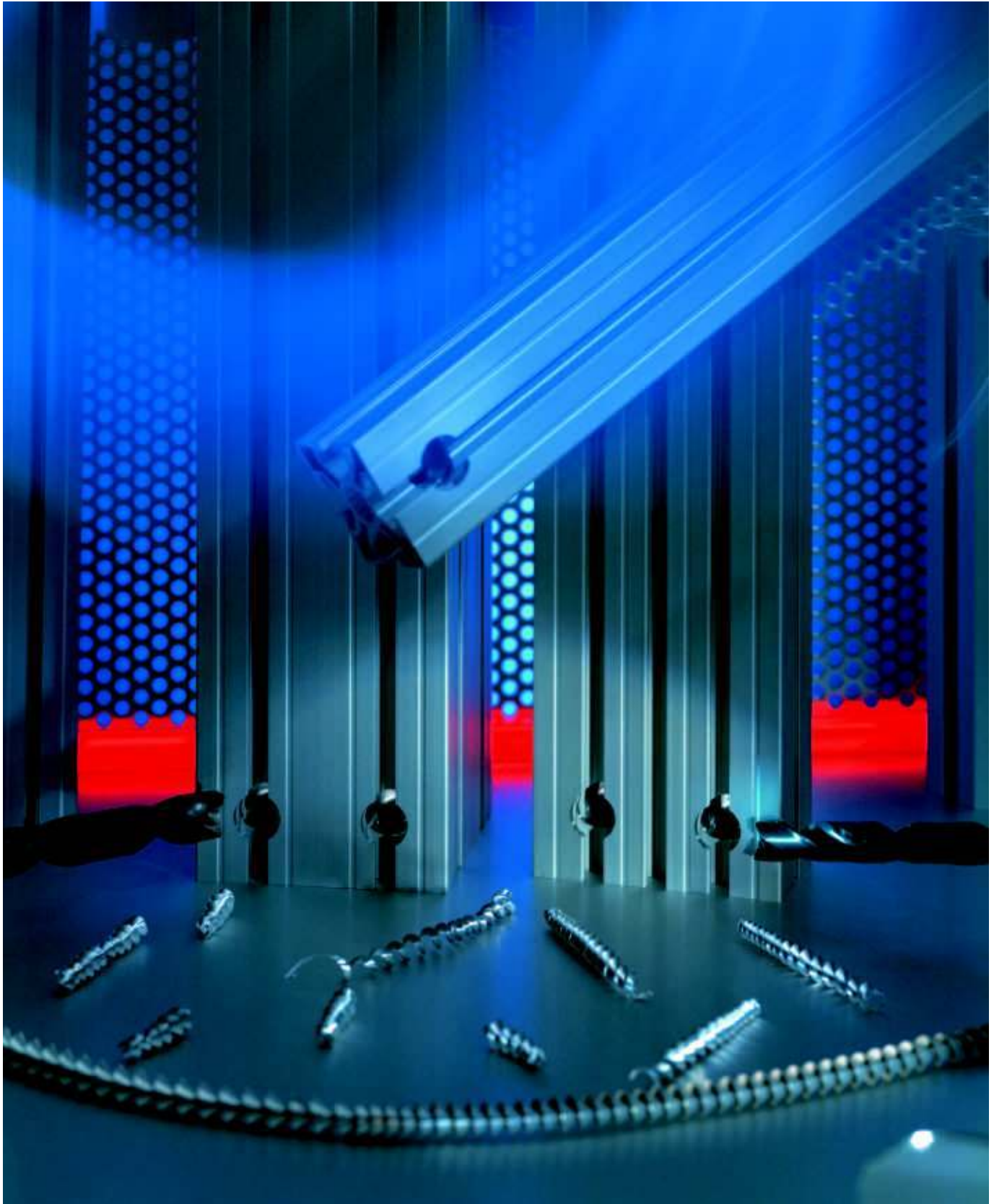

## Drill jig and special drill bits

### Application

The drill jig and special drill bits make it easy to drill the holes for KANYA's patented PVS connector. The main advantage of the drill jig is that it clamps directly onto the extrusion. The rotating stop, for square or mitred cuts, guarantees the precise drilling distance.

The HSS special drill bit, with the MT2 Morse taper shank, is ground flat to cut the extrusion surface. It can be re-sharpened as often as necessary.

A special drill bit with a 90° point is used to drill the C03-8, B01-8 softline extrusion and the A02-8 and C02-8 angle extrusions.

**Standard 90° joint**  
"25" stop

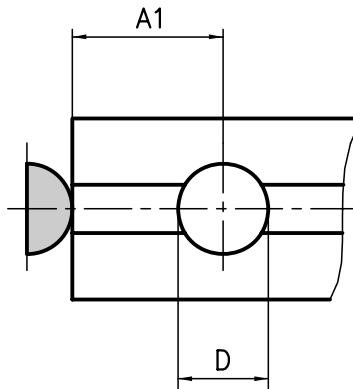

**Mitre joint**  
"32" stop

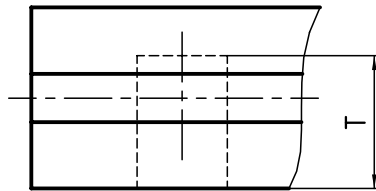
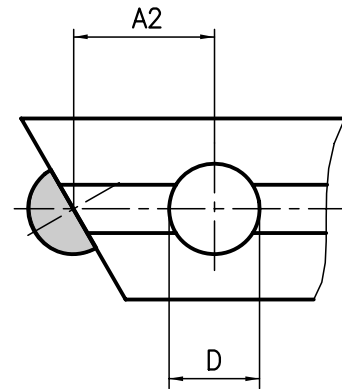

### Note

The 7.3 mm Ø holes for 20x20/40 extrusions are drilled using a normal twist drill bit without a drill jig.

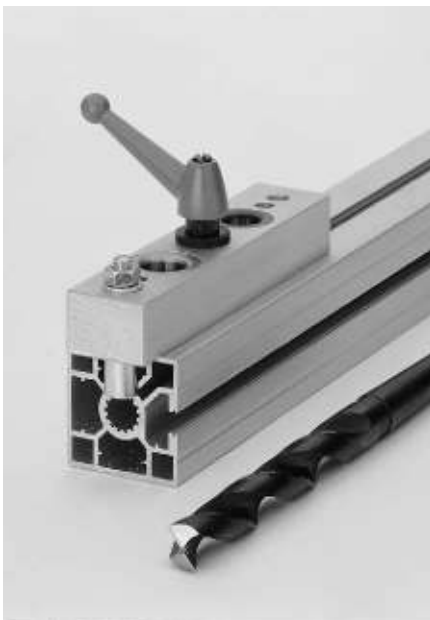

### Machining data

Extrusion type	D	A1	A2	T
50 base	18.1	25	32	33
40 base	18.1	25	32	28
30 base	15.1	25	32	22
20x47/95/150 base	15.1	25	32	18
20x20/40 base	7.3	25	25	-

### Order data

### Order number

Order data	Order number
<b>Drill jig</b>	
50/40/30 base	AB95-0
<b>Special drill bits</b>	
to fit the drill jig	
50/40 base	A96-1
30 base	B96-2
A02-8, C02-8, C03-8 extrusions	A96-3
B01-8 extrusion	B96-3

## Punch cutter PVS®-EASY



### Application

With the punch cutter its possible to break out a part of the slot of the «EASY»-extrusions to insert the Allen-key into the slot to fix the connector. The tool is sliding in the slot of the extrusion from the cut side The adjustable stop gives the right position on the extrusion.

## Multi-purpose tool PVS®-EASY

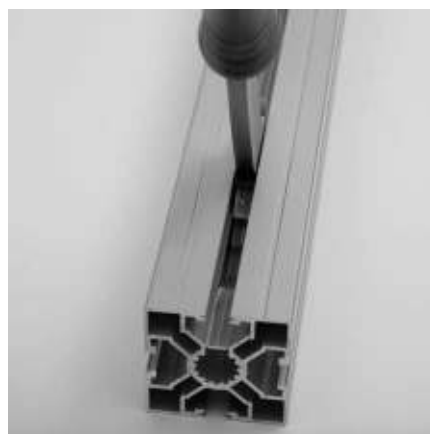

### Application

With the multi-purpose tool you can partially break the slot and then insert the Allen-key at that position. The Allen key is then used to assemble the connector. The tool is very simple, and not comparable with the punch cutter.

Order data	Order number
Punch cutter PVS®-EASY	E96-1

Order data	Order number
Multi-purpose tool PVS®-EASY	E96-5

## Allen key set SW 1,5 – 10

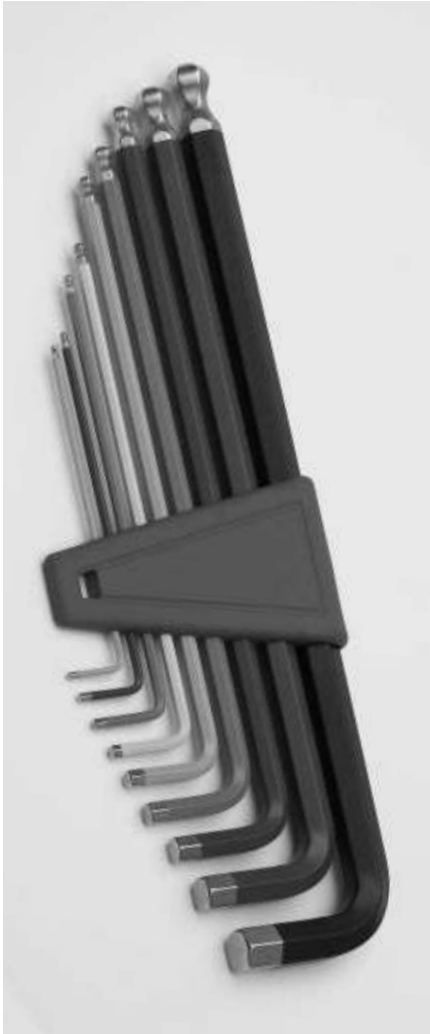

### Application

For allen screws.

The ball at the end allows it to screw into angular positions with the allen key.

This is necessary for the new function of the patent PVS®-EASY connectors.



Order data	Order number
------------	--------------

Allen key set SW 1,5 – 10	E97-5
------------------------------	-------

SW = wrench size

## KANYA-Allen key SW 6



Order data	Order number
------------	--------------

KANYA-Allen key SW 6 short	E97-1
KANYA-Allen key SW 6 long	E97-2

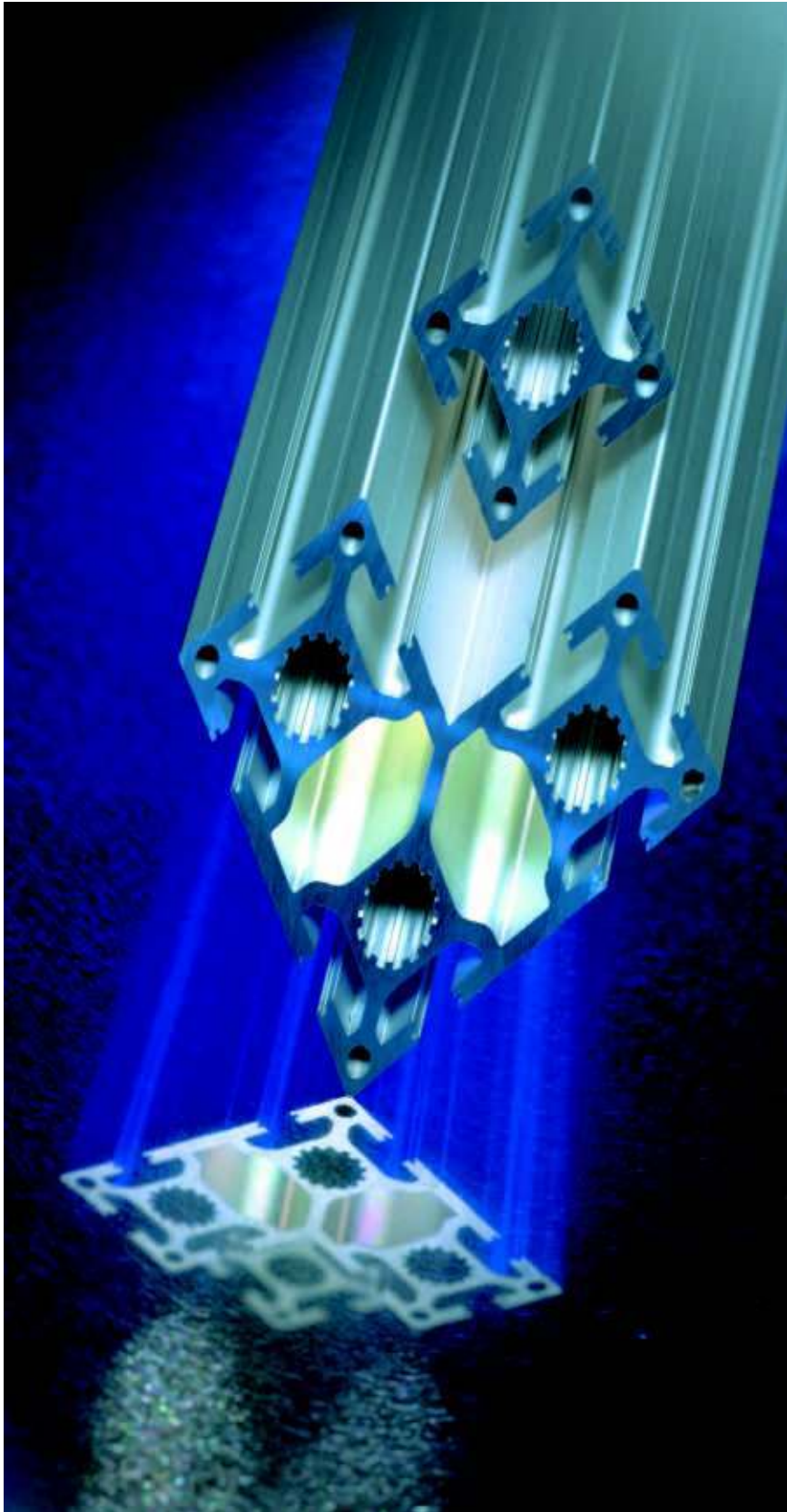

## Get the KANYA Construction kit for your CAD system!

The KANYATHEK3D software not only offers you the complete product details for your CAD system, but also the possibility to edit the extrusions and much more.

Get the KANYA product library construction kit directly from the CD-ROM onto your CAD system. The software generates all the KANYA products in all common CAD formats. Direct interfaces are available for a constantly growing number of 2D- and 3D-CAD systems.

Edit extrusions and other products with your own inputs using KANYATHEK and afterwards load them on your CAD or simply generate the parts list automatically for your electronic order.

**A unique KANYA service.**

# KANYATHEK® – Product library and design software

The installation and application of the KANYATHEK software on your computer is simple and problem-free. In addition, a monitoring function automatically checks for the availability of updates or interesting news on KANYA whenever you start up KANYATHEK. You then choose if you would like to receive the information and updates.

## Application

You choose the required product and edit it virtually according to the requirements. Afterwards you can export the configured element onto your CAD system and transfer the required amount to the order parts list. You can save the parts list anytime and use it on demand. Based on the precise product number and process coding, the parts list can be audited at anytime and transferred to us at the touch of a button.

## The KANYATHEK and its advantages

- Significant reduction in design time.
- Safe electronic order release via the automatically generated parts list.
- All KANYA elements are available as models.
- Simple and logic layout- no special prior knowledge necessary.
- Your KANYA documents are always up-to-date.



### 1. Product choice

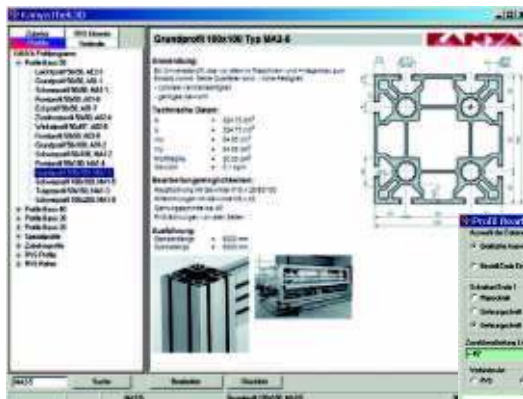

### 2. Editing extrusion

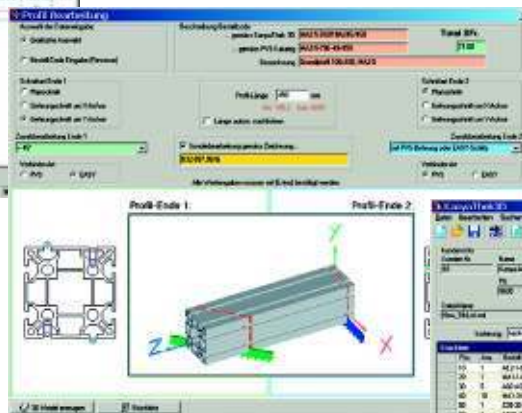

### 3. Generate parts list

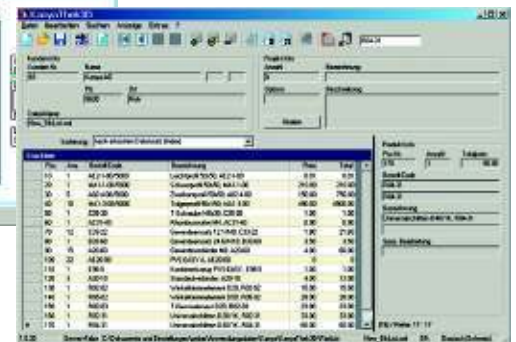

## System requirements

Windows 2000, Windows XP, Windows Vista; Microsoft .NET Framework 1.1; at least 256 MB RAM; at least 200 MB free hard disc and at least 256 colors (1024 x 768 Pixel)

<b>Term</b>	<b>Page</b>	<b>Term</b>	<b>Page</b>	<b>Term</b>	<b>Page</b>
19" auxiliary extrusion, 30 mm base	81	Box frame extrusion 30x95	82	End caps	126
19" auxiliary extrusion, 50 mm base	81	Buffer	155	End stop	155
<b>A</b>		<b>C</b>		<b>F</b>	
Acrylic glass	134	Cable ducts	124	Face extrusion 20x150	77
Allen key set	159	Cable ties	125	Face extrusion 20x20	74
Al-heavy duty hinges fixed type	137	Castors	119	Face extrusion 20x40	75
Aluminium hinges lift-off type	136	Channel reducing strip	127	Face extrusion 30x30	63
Aluminium filler strip	126	Channel reducing strips and filler strips	128	Face extrusion 30x50	68
Aluminium sheets	132	Clamping block	107	Face extrusion 30x300	73
Angle extrusion 25x35	86	Clamping block	108	Face extrusion 40x40	49
Angle extrusion 31x31	86	Clamping extrusion 16x29	84	Face extrusion 40x80	55
Angle extrusion 38x38	86	Clamping nuts	111	Face extrusion 50x50	38
Angle extrusion 40x45°	53	Clamping sealing strip	131	Face extrusion 50x100	43
Angle extrusion 50x45°	39	Composite panels	133	Face extrusion with panel slots 30x30	63
Angle extrusion 60x120	86	Corner extrusion 30°	66	Face extrusion with panel slots 30x50	69
Angle extrusion 60x60	87	Corner extrusion 45°	66	Face extrusion with panel slots 30x60	69
Angle extrusion 70x70	87	Corner extrusion 45°	52	Face extrusion with panel slots 30x100	72
Angle extrusion 100x100	87	Corner extrusion 60°	67	Face extrusion with rip off slots 40x40	51
Anti-twist spigots	112	Corner extrusion 20x20	74	Face extrusion with rip off panel slots 50x50	40
Arrester plate	143	Corner extrusion 30x30	64	Flange plates	102
Attachment bracket	109	Corner extrusion 40x40	50	Flat sealing element	146
<b>B</b>		Corner extrusion 50x50	38	Floor bolting bracket	116
Ball catches	142	Corner extrusion with panel slots 30x30	64	Foot plates	116
Base extrusion 20x20	74	Corner extrusion with rip off slots 40x40	51	Four sided extrusion 40x40	52
Base extrusion 20x40	75	Corner pieces	139	Full-plastic panels	134
Base extrusion 30x100	72	Covering cap for PVS-connector	96	<b>G</b>	
Base extrusion 30x30	82	<b>D</b>		Grid extrusion	131
Base extrusion 30x50	68	Door sealing strip	130	<b>H</b>	
Base extrusion 30x60	70	Double bolting bracket	117	Halfround threaded plates	110
Base extrusion 30x60	49	Double clamping extrusion 16x50	84	Hammer nuts	112
Base extrusion 40x40	54	Double face extrusion 30x30	65	Hand rail extrusion 50x50	78
Base extrusion 40x80	37	Double face extrusion 40x40	50	Handle strip	143
Base extrusion 50x50	41	Double face extrusion 50x50	39	Handle strip extrusion	88
Base extrusion 50x100	41	Double extrusion nuts	111	Handles	140
Base extrusion 60x60	70	Double threaded plates	110	Heavy duty extrusion 100x100	45
Base extrusion 80x80	59	Double trolley	121	Heavy duty extrusion 30x30	62
Base extrusion 100x100	44	Drill jig and special drill bits	157	Heavy duty extrusion 50x100	42
Base plates	116	<b>E</b>		Heavy duty extrusion 50x50	37
Beam extrusion 40x120	56	Electrically conductive leveling feet	115	Heavy duty extrusion 80x160	61
Beam extrusion 40x160	57	Enclosure panels	132		
Beam extrusion 50x150	46				
Beam extrusion 80x120	60				
Box frame extrusion 20x40	76				
Box frame extrusion 20x47	76				
Box frame extrusion 20x95	77				

<b>Term</b>	<b>Page</b>	<b>Term</b>	<b>Page</b>	<b>Term</b>	<b>Page</b>
Heavy duty extrusion 100x200	47	<b>O</b>		Slot extrusion 20x80	79
Hinge extrusion, type A	88	Octagonal extrusion, 20 mm base	76	Slot extrusion 20x120	79
Hinge extrusion, type B	88	Octagonal extrusion, 30 mm base	71	Snap-lock	145
Hinge extrusion, type C	88	Oil scraper	154	Softline extrusion 20x20	75
H-strip	128	Oil scraper support	154	Softline extrusion 30x30	65
<b>I</b>		<b>P</b>		Softline extrusion 40x40	53
Inset lock	144	Panel clamp extrusion 13.5x50	85	Spacer for the roller shield	154
Installation rings	125	Plastic hinges fix	136	Special extrusion 80x80	78
<b>J</b>		Plastic hinges lift-off type	136	Special hinges lift-off type	137
Joint	138	Plastic slide extrusion	122	Steel shafts	149
Joints with clamp lever	138	Polycarbonate	134	Steel wire mesh	135
Junction plates	147	Punch cutter PVS-EASY	158	Super lightweight extrusion 40x40	48
<b>K</b>		PVC filler strips	127	Super lightweight extrusion 30x30	62
KANYA-Allen key	159	PVS connectors	92–95	Support extrusion 11x30.5	85
Kanyathek	161	PVS light	101	Supporting extrusion	129
<b>L</b>		PVS-EASY	99	Suspended guard fittings	135
L-shaped extrusion 80x80x40	58	<b>Q</b>		<b>T</b>	
Leg bolt-down socket	118	Quick-release fasteners	143	T-bolts	109
Leveling feet	114	<b>R</b>		Threaded inserts	113
Leveling feet with shock absorbers	115	Rectangular tube	89	Threaded plates	110
Light extrusion nuts	111	Retaining clips	125	Triple channel extrusions 30x15	80
Light extrusion 40x80	54	Rhomboid nuts	112	Tube handle offset	141
Light extrusion 40x120	55	Rod locks	144	Tube handle straight	141
Light extrusion 50x50	36	Roller shield	153	<b>U</b>	
Lightweight extrusion 30x30	62	Roller-mounted support	121	U-clamping extrusion 8x13.5	85
Lightweight extrusion 40x40	48	Rollers, plastic	120	U-sealing strip	131
Lightweight extrusion 80x80	59	Rollers, steel	153	Uniblock	108
Linear sliding block	149	Runner extrusion 30x30	83	<b>W</b>	
<b>M</b>		Runner extrusion 30x50	83	Wall rail 50x18	80
Magnetic fasteners	142	<b>S</b>		Wedge extrusion	129
Micro chipboard	133	Safety-edge extrusion	130	<b>Z</b>	
Mounting bracket and dowel	107	Safety switch	145	Zn-diecasting hinges fixed type	137
Mounting brackets	106	Sealing plates	146		
Multi-purpose tool PVS-EASY	158	Sealing washer	147		
<b>N</b>		Semi-circular sealing strip	130		
Non-swivel castors	119	Shaft clamping block	148		
		Shaft clamping extrusions	150		
		Shaft support extrusion	151		
		Single bolting bracket	117		
		Slide plates	152		
		Sliding hook	123		



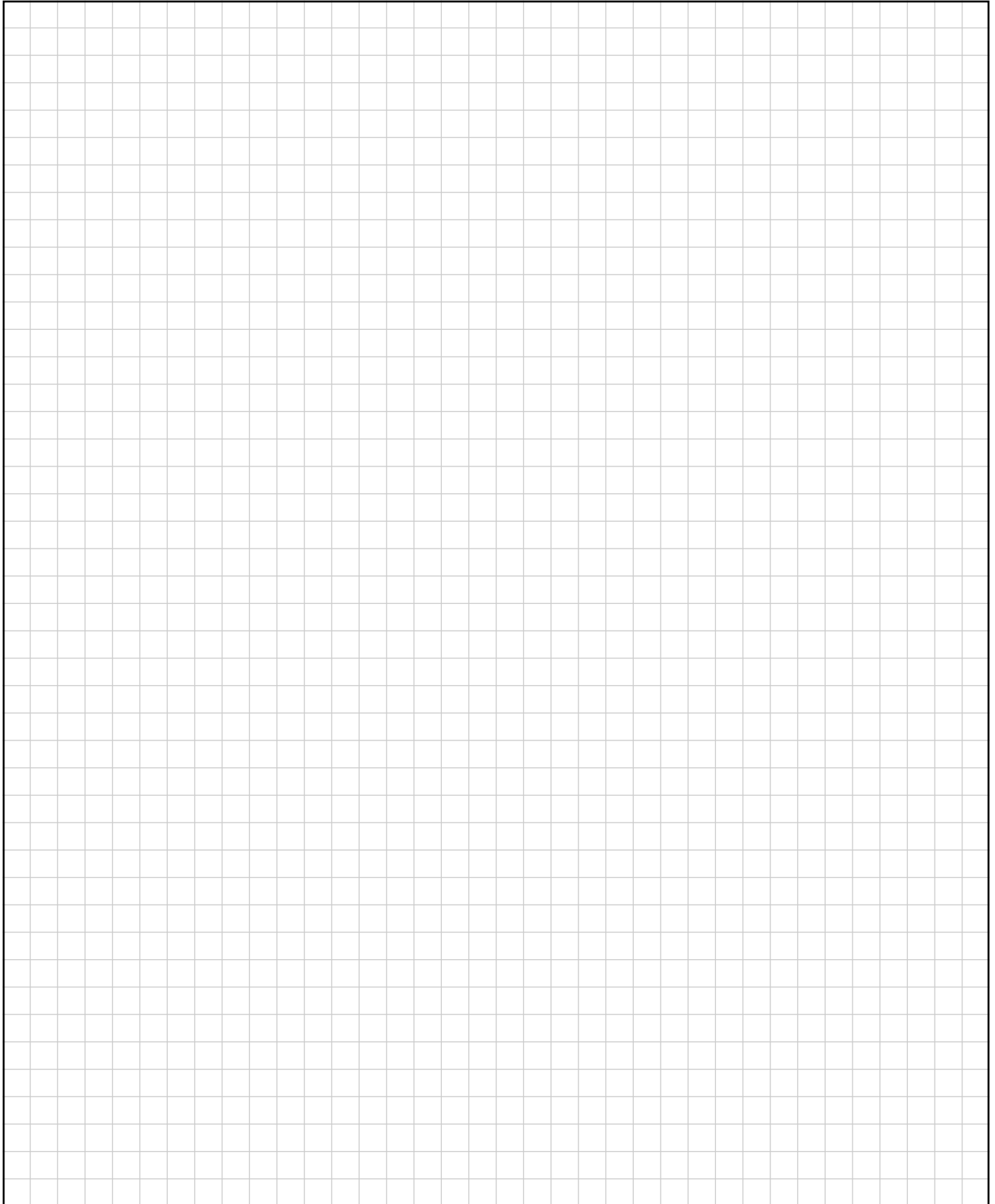





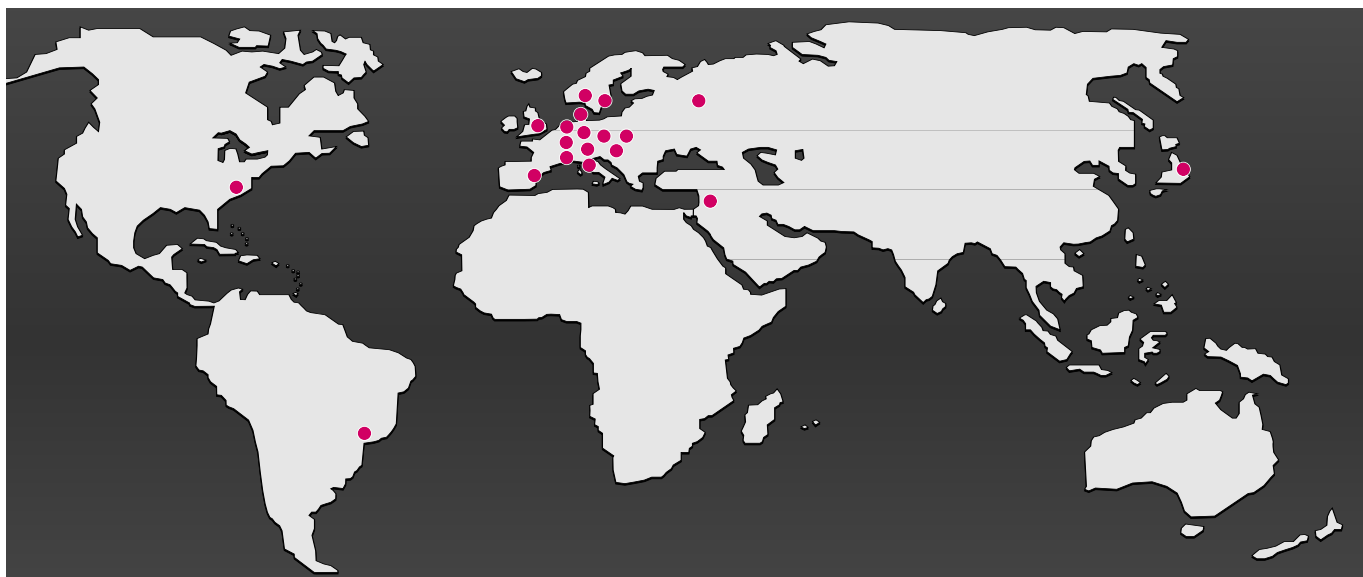

**A VENTOR SICHERHEITSSYSTEME – AUTOMATISIERUNG**  
 Falkenau 11  
 A-4690 Schwanenstadt  
 Tel: 0043 (0)7673 80511-0  
 Fax: 0043 (0)7673 80511-40  
 e-mail: verkauf@ventor.at  
 Internet: <http://www.ventor.at>

**B MAM S.A.**  
 Industrie/Automation  
 Rue de la Station 9–11  
 B-1435 Mont St. Guibert  
 Tel: 0032-10/657 012  
 Fax: 0032-10/658 791  
 e-mail: m.a.m.industrie@skynet.be

**BR ABG – INDUSTRIA COMERCIO LTDA.**  
 Av. das Araucárias, 509 – Barigüi  
 CEP 83707-000  
 Araucária-Paraná-Brasil  
 Tel: 0055-41/643 1384  
 Fax: 0055-41/643 3628  
 e-mail: info@kanya.com.br  
 Internet: <http://www.kanya.com.br>

**CZ VISIMPEX a.s.**  
 Seifertova 33  
 CZ-750 02 Přerov

**SK**  
 Tel: 00420 581 808 134  
 Fax: 00420 581 808 515  
 e-mail: kanya@visimpex.cz  
 Internet: <http://www.kanya.cz>

**D Nord PLZ 1,2,3,4,5 DRECKSHAGE GMBH & CO. KG**  
 Walter-Werning-Straße 7  
 D-33699 Bielefeld  
 Tel: 0049-521/92 59-0  
 Fax: 0049-521/92 59 289  
 e-mail: profile@dreckshage.de  
 Internet: <http://www.dreckshage.de>

**D Süd PLZ 0,6,7,8,9 KANYA DEUTSCHLAND GMBH**  
 Meufelsdorferstraße 25  
 D-95615 Marktredwitz  
 Tel: 0049-9231/603 860  
 Fax: 0049-9231/603 861  
 e-mail: info@kanya-deutschland.de  
 Internet: <http://www.kanya-deutschland.de>

**DK JJ MECHATRONIK AS**  
 Industriparken 17  
 DK-4450 Jyderup  
 Tel: 0045-59/25 81 00  
 Fax: 0045-59/25 81 01  
 e-mail: info@jjas.dk  
 Internet: <http://www.jjas.dk>

**ESP IBALTEC SISTEMAS, S.L.**  
 C/. Josep Soler, 74-76 bjs.  
 E - 08310 ARGENTONA (Barcelona)  
 Tel: 0034-93/756 11 53  
 Fax: 0034-93/797 40 34  
 e-mail: info@ibaltec.com  
 Internet: <http://www.ibaltec.com>

**F BERNAY AUTOMATION S.A.**  
 B.P. 451-1, Rue de Menneval  
 F-27304 Bernay Cedex  
 Tel: 0033-232/473 510  
 Fax: 0033-232/430 188  
 e-mail: info@bernay-automation.com  
 Internet: <http://www.bernay-automation.com>

**GB THINKING SPACE SYSTEMS Ltd.**  
 Unit 2, The Quadrangle  
 Abbey Park Industrial Estate  
 Romsey  
 Hampshire SO51 9DL, UK  
 Tel: 0044-(0)1794/51 66 33  
 Fax: 0044-(0)1794/51 66 32  
 e-mail: kanya@thinking-space.com  
 Internet: <http://www.kanya-uk.co.uk>

**I TECNO-CENTER S.R.L.**  
 C.so Lombardia, 41  
 I-10078 Venaria Reale (TO)  
 Tel: 0039-011/455 11 21  
 Fax: 0039-011/455 75 95  
 e-mail: info@tecnocenter.it  
 Internet: <http://www.tecnocenter.it>

**IL CONLOG LTD.**  
 7 Leshem St.  
 P.O. Box 3571  
 IL-Petach-Tikva 49134  
 Tel: 00972-3/926 95 95  
 Fax: 00972-3/923 33 67  
 e-mail: conlog@conlog.co.il  
 Internet: <http://www.conlog.co.il>

**J MIWA CO. LTD.**  
 No. 632, SEKO 2-chome  
 Moriyama-ku  
 J-Nagoya 463 0068  
 Tel: 0081-52/795 60 11  
 Fax: 0081-52/795 33 66  
 e-mail: postmiwa@miwa-inc.co.jp  
 Internet: <http://www.miwa-inc.co.jp>

**NL TEVEL COMPONENTS BV**  
 Endepoelstraat 4  
 NL-6942 GL Didam  
 Tel: 0031-(0)316/342 815  
 Fax: 0031-(0)316/343 086  
 e-mail: components@tevel.nl  
 Internet: <http://www.tevel.nl>

**PL TABAL Sp. J.**  
 ul. Energetyków 14  
 PL-20-468 Lublin  
 Tel: 0048-(0)81/749 09 11  
 Fax: 0048-(0)81/749 01 28  
 e-mail: kanya@tabal.pl  
 Internet: <http://www.tabal.pl>

**RU SERVOTECHNICA ZAO**  
 22, Vyborgskaya str.  
 125130 Moscow, Russia  
 Tel: 0007 495/797 8866  
 Fax: 0007 495/450 0043  
 e-mail: info@servotechnica.ru  
 Internet: <http://www.servotechnica.ru>

**S EIE MASKIN AB**  
 Box 7  
 124 21 Bandhagen  
 Tel: 0046-8/727 88 00  
 Fax: 0046-8/727 88 99  
 e-mail: eie@eie.se  
 Internet: <http://www.eie.se>

**USA A-LINE CORPORATION**  
 1303 Upper Asbury Ave  
 Charlotte NC 28206 – USA  
 Tel: 01-704/332-1059  
 Fax: 01-704/332-4729  
 e-mail: sales@aline1.com  
 Internet: <http://www.aline1.com>

**KANYA-Messebau-Partner weltweit**  
 Lüdemann & Co.  
 Internationaler Messebau  
 Gilcherweg 21  
 D-22851 Norderstedt  
 Tel: 0049-40/524 3405  
 Fax: 0049-40/524 3258

**Headquarters** • KANYA AG/SA/Ltd. • Neuhofstrasse 9 • CH-8630 Rüti  
 Tel. ++41-(0)55/251 58 58 • Fax ++41-(0)55/251 58 68 • e-mail: info@kanya.com • Internet <http://www.kanya.com>



**THINKING SPACE SYSTEMS Ltd.**

Unit 2, The Quadrangle  
Abbey Park Industrial Estate  
Romsey

Hampshire, SO51 9DL, UK

Tel: ++44-(0)1794/51 66 33

Fax: ++44-(0)1794/51 66 32

e-mail: [kanya@thinking-space.com](mailto:kanya@thinking-space.com)

Internet: <http://www.kanya-uk.co.uk>